

COVERING

Grey anti-trace thermoplastic wheel, hardness 85 Shore A.

WHEEL CENTRE BODY

Polypropylene-based (PP) technopolymer.

ROLLING ACTION

Hub with pass-through hole.

FIXED PLATE BRACKET

Zinc-plated steel or AISI 304 stainless steel (SST version) sheet, the bracket is designed to withstand loads up to 1800N.

TURNING PLATE BRACKET

Zinc-plated steel or AISI 304 stainless steel (SST version) sheet, the bracket is designed to withstand loads up to 1800N. The presence of a double ball race and direct contact between the plate and the ball race ring with built-in pin ensure excellent manoeuvrability. Does not require maintenance.

It consists of (see Fig.1):

1. fitting plate: electrolytically zinc-plated steel or AISI 304 stainless steel sheet;
2. fork: electrolytically zinc-plated steel or AISI 304 stainless steel sheet;
3. ball race ring: electrolytically zinc-plated steel or AISI 304 stainless steel sheet;
4. central pin: incorporated in the plate, cold reflanged;
5. rotation system: dual grease-lubricated ball race;
6. dust seal: RAL 7015 dark grey technopolymer.

BRAKE

Total brake that locks the wheel and bracket rotation. The optimised dimensions and the retractable pedal ensure minimal space occupied and maximum actuation ease. Hardened carbon steel or stainless steel (SST version) spring.

STANDARD EXECUTIONS

- **PBL**: fixed plate bracket, without brake.
 - **SBL**: turning plate bracket, without brake.
 - **SBF**: turning plate bracket, with brake.
 - **FBL**: turning plate bracket and centre pass-through hole, without brake.
 - **FBF**: turning plate bracket and centre pass-through hole, with brake.
- Index for bracket material:
- **N**: zinc-plated steel plate bracket.
 - **N-SST**: AISI 304 stainless steel bracket.

APPLICATIONS

Excellent rolling resistance and elasticity features. For further information see wheel technical data sheet RE.G1 (see page 1856).



1	
2	
3	
4	
5	
6	
7	
8	
9	
10	
11	
12	
13	
14	
15	
16	
17	
18	

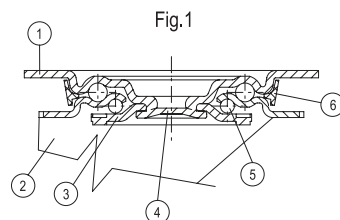

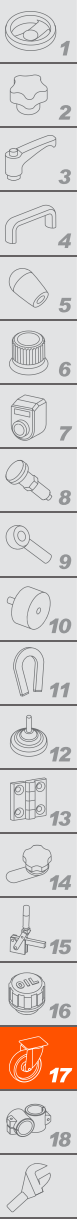

RE.G1-PBL-N
RE.G1-PBL-N-SST

RE.G1-SBL-N
RE.G1-SBL-N-SST

RE.G1-SBF-N
RE.G1-SBF-N-SST

RE.G1-FBL-N
RE.G1-FBL-N-SST

RE.G1-FBF-N
RE.G1-FBF-N-SST

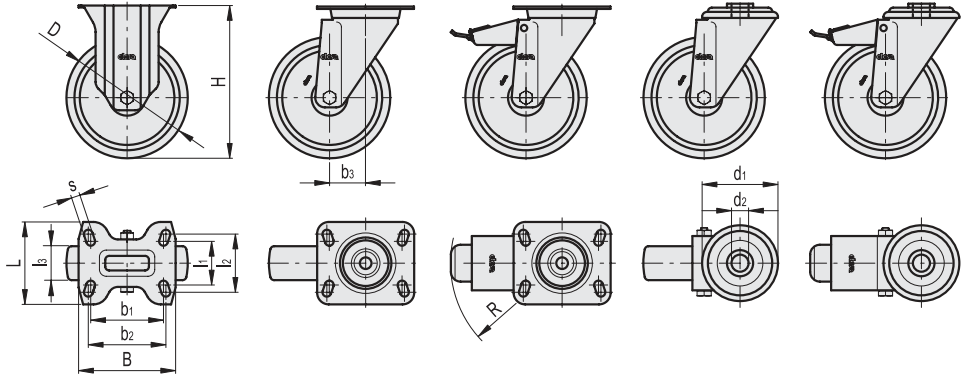

Conversion Table	
1 mm = 0.039 inch	
mm	inch
80	3.15
100	3.94
125	4.92
150	5.91

RE.G1-N

METRIC

Code	Description	D	d1	d2	b1	l1	b2	l2	l3	H	B	L	s	b3	R	Rolling resistance# [N]	Dynamic carrying capacity# [N]	Δ
452651	RE.G1-080-PBL-N	80	-	-	75	45	80	60	30	107	100	85	9	-	-	700	700	360
452656	RE.G1-100-PBL-N	100	-	-	75	45	80	60	30	128	100	85	9	-	-	1000	1000	390
452661	RE.G1-125-PBL-N	125	-	-	75	45	80	60	35	156	100	85	9	-	-	1200	1200	610
452666	RE.G1-150-PBL-N	150	-	-	105	73	105	85	45	194	140	114	11	-	-	1800	1800	1350
452551	RE.G1-080-SBL-N	80	-	-	75	45	80	60	30	107	100	85	9	39	-	700	700	600
452556	RE.G1-100-SBL-N	100	-	-	75	45	80	60	30	128	100	85	9	35	-	1000	1000	700
452561	RE.G1-125-SBL-N	125	-	-	75	45	80	60	35	156	100	85	9	37	-	1200	1200	860
452566	RE.G1-150-SBL-N	150	-	-	105	73	105	87	45	194	140	110	11	56	-	1800	1800	1720
452601	RE.G1-080-SBF-N	80	-	-	75	45	80	60	30	107	100	85	9	39	120	700	700	790
452606	RE.G1-100-SBF-N	100	-	-	75	45	80	60	30	128	100	85	9	35	120	1000	1000	850
452611	RE.G1-125-SBF-N	125	-	-	75	45	80	60	35	156	100	85	9	37	120	1200	1200	1000
452616	RE.G1-150-SBF-N	150	-	-	105	73	105	87	45	194	140	110	11	56	156	1800	1800	2000
452701	RE.G1-080-FBL-N	80	73	12	-	-	-	-	30	107	-	-	-	39	-	700	700	600
452706	RE.G1-100-FBL-N	100	73	12	-	-	-	-	30	128	-	-	-	35	-	1000	1000	700
452711	RE.G1-125-FBL-N	125	73	12	-	-	-	-	35	156	-	-	-	37	-	1200	1200	860
452716	RE.G1-150-FBL-N	150	102	20	-	-	-	-	45	188	-	-	-	56	-	1800	1800	1720
452751	RE.G1-080-FBF-N	80	73	12	-	-	-	-	30	107	-	-	-	39	120	700	700	790
452756	RE.G1-100-FBF-N	100	73	12	-	-	-	-	30	128	-	-	-	35	120	1000	1000	850
452761	RE.G1-125-FBF-N	125	73	12	-	-	-	-	35	156	-	-	-	37	120	1200	1200	1000
452766	RE.G1-150-FBF-N	150	102	20	-	-	-	-	45	188	-	-	-	56	156	1800	1800	2000

RE.G1-N-SST

INOX STAINLESS STEEL

METRIC

Code	Description	D	d1	d2	b1	l1	b2	l2	l3	H	B	L	s	b3	R	Rolling resistance# [N]	Dynamic carrying capacity# [N]	Δ
452653	RE.G1-080-PBL-N-SST	80	-	-	75	45	80	60	30	107	100	85	9	-	-	700	700	590
452658	RE.G1-100-PBL-N-SST	100	-	-	75	45	80	60	30	128	100	85	9	-	-	1000	1000	610
452663	RE.G1-125-PBL-N-SST	125	-	-	75	45	80	60	35	156	100	85	9	-	-	1200	1200	760
452553	RE.G1-080-SBL-N-SST	80	-	-	75	45	80	60	30	107	100	85	9	39	-	700	700	330
452558	RE.G1-100-SBL-N-SST	100	-	-	75	45	80	60	30	128	100	85	9	35	-	1000	1000	360
452563	RE.G1-125-SBL-N-SST	125	-	-	75	45	80	60	35	156	100	85	9	37	-	1200	1200	590
452603	RE.G1-080-SBF-N-SST	80	-	-	75	45	80	60	30	107	100	85	9	39	120	700	700	530
452608	RE.G1-100-SBF-N-SST	100	-	-	75	45	80	60	30	128	100	85	9	35	120	1000	1000	570
452613	RE.G1-125-SBF-N-SST	125	-	-	75	45	80	60	35	156	100	85	9	37	120	1200	1200	740
452703	RE.G1-080-FBL-N-SST	80	73	12	-	-	-	-	30	107	-	-	-	39	-	700	700	760
452708	RE.G1-100-FBL-N-SST	100	73	12	-	-	-	-	30	128	-	-	-	35	-	1000	1000	790
452713	RE.G1-125-FBL-N-SST	125	73	12	-	-	-	-	35	156	-	-	-	37	-	1200	1200	900
452753	RE.G1-080-FBF-N-SST	80	73	12	-	-	-	-	30	107	-	-	-	39	120	700	700	700
452758	RE.G1-100-FBF-N-SST	100	73	12	-	-	-	-	30	128	-	-	-	35	120	1000	1000	780
452763	RE.G1-125-FBF-N-SST	125	73	12	-	-	-	-	35	156	-	-	-	37	120	1200	1200	890