

THIS DRAWING IS UNPUBLISHED. RELEASED FOR PUBLICATION  
 © COPYRIGHT - By - ALL RIGHTS RESERVED.

LOC	DIST	REVISIONS			
P	LTR	DESCRIPTION	DATE	DWN	APVD
AF	50	T4	REVISED PER ECR-22-126312	14JAN2022	PC TD

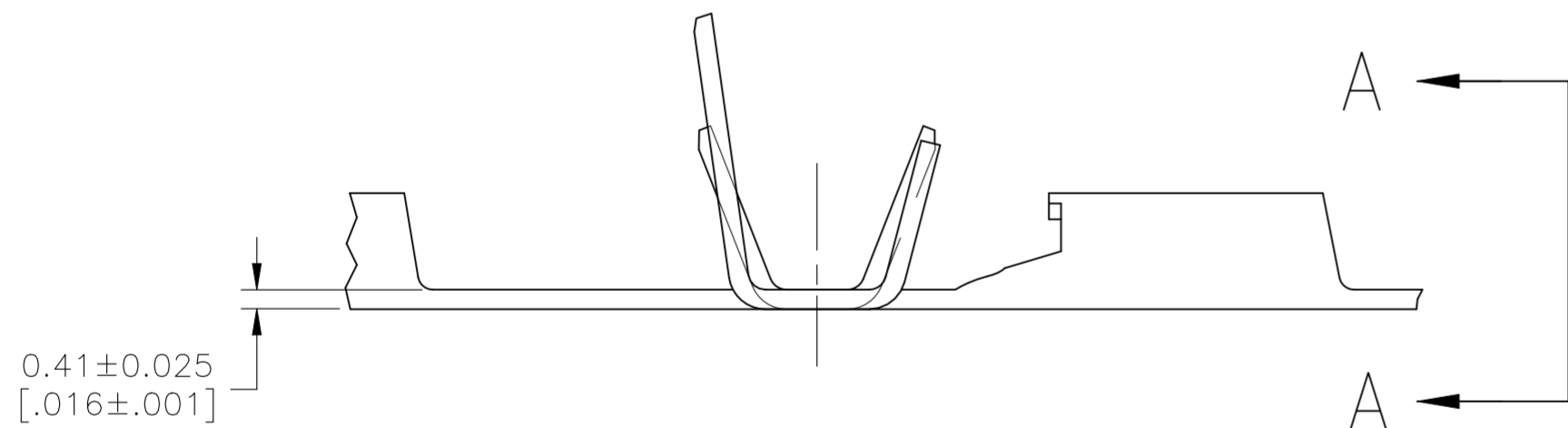

- 1 CONTINUOUS STRIP ON REELS.
- 2 MATING TAB THK TO BE 0.84-0.76 [.033-.030]
- 3 WIRE SIZE IS #18-#14 AWG.
- 4 INSULATION RANGE IS 1.52-3.81 [.060-.150] DIA.
- 5 REEL WITH INTERLEAVING PAPER
- 6 RECEPTACLE LENGTH CAN BE GREATER BY UP TO 0.25 [.010] MAX FROM OPPOSITE SIDE.
- 7 PREPRODUCTION - FASR REQUIRED
- 8 SUPPLY CONDITION

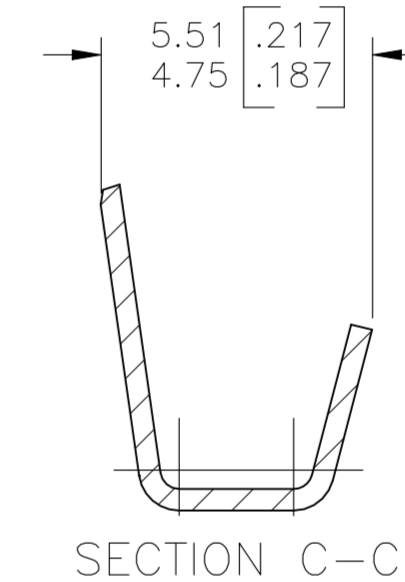
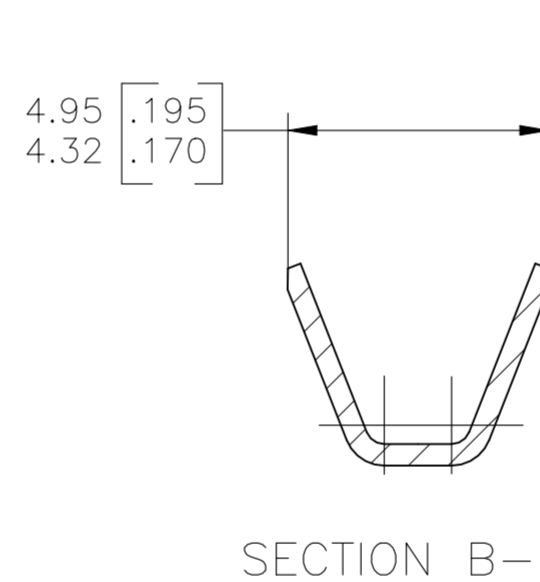
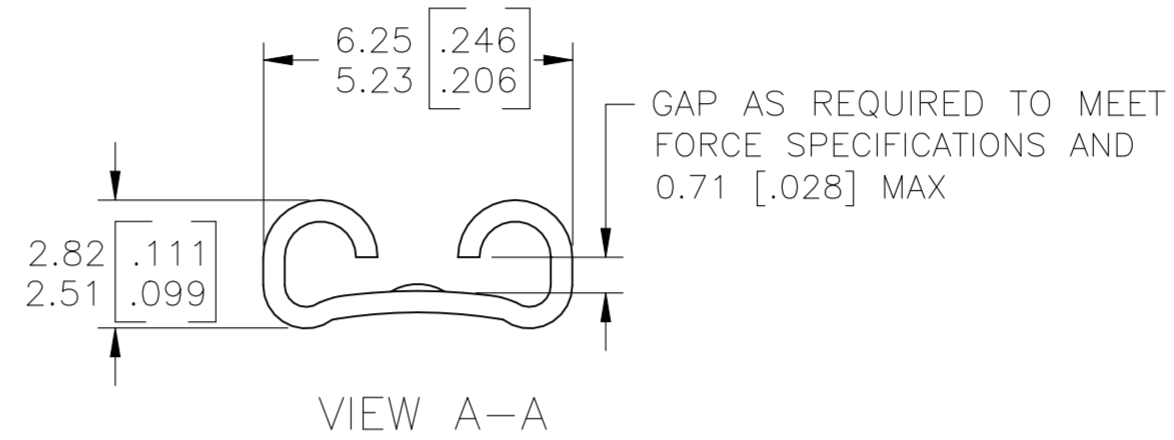
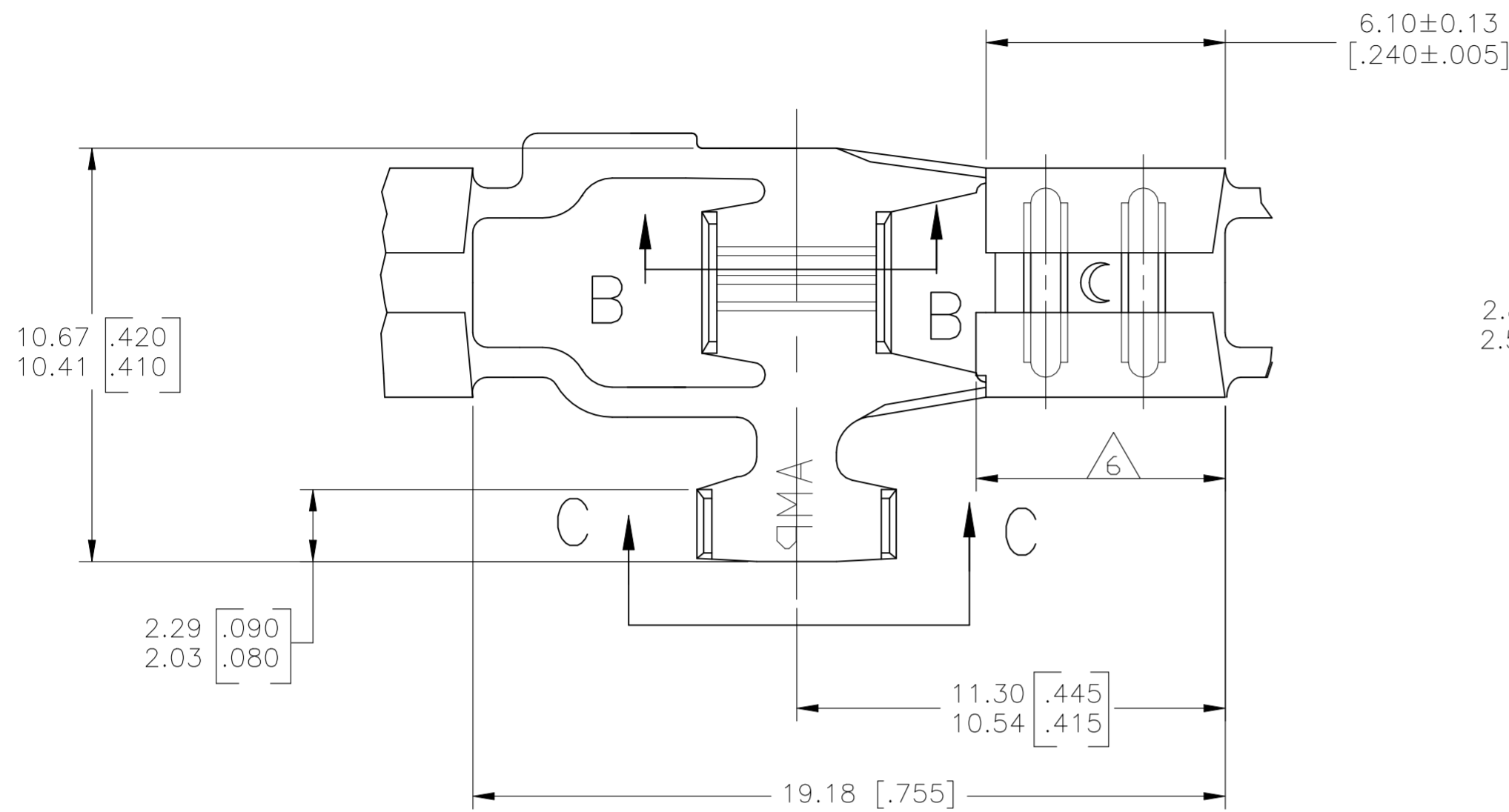

PART NO	WIRE		INSULATION DIAMETER (MAX)	WIRE BARREL CRIMP			TENSILE STRENGTH POUNDS	
	QTY	SIZE AWG		WIDTH	CRIMP HEIGHT	CRIMPER		ANVIL
63316	1	14	.150	.120	.071	F	FLAT	50
	1	16			.063			30
	1	18			.057			20

REVERSE REELED	-	BRASS	63316-8
5 REVERSE REELED	0.00381 [.000150] MIN NICKEL	T2 CR STEEL	63316-7
8	0.00398 [.000157] MIN SILVER	H04 PHOS BRZ	7 63316-6
5 REVERSE REELED	TIN	BRASS	63316-5
	0.00381 [.000150] MIN NICKEL	T2 CR STEEL	8 63316-3
	TIN	BRASS	8 63316-2
	-	BRASS	8 63316-1
	FINISH	MATERIAL	PART NO.

THIS DRAWING IS A CONTROLLED DOCUMENT.

DWN: JR RUTH 6/16/87  
 CHK: MS FEHER 6/16/87  
 APVD: C MEYERS 6/16/87

TE Connectivity

RECEPTACLE, FLAG, FASTON, 4.75 [.187] SERIES

SIZE: A2 CAGE CODE: 00779 DRAWING NO: C-63316 RESTRICTED TO: -

SCALE: 7:1 SHEET: 1 OF 1 REV: T4

CUSTOMER DRAWING