

# ENERGIZER 362

**ZERO**MERCURY<sup>®</sup>

**SILVER OXIDE**



## Industry Standard Dimensions

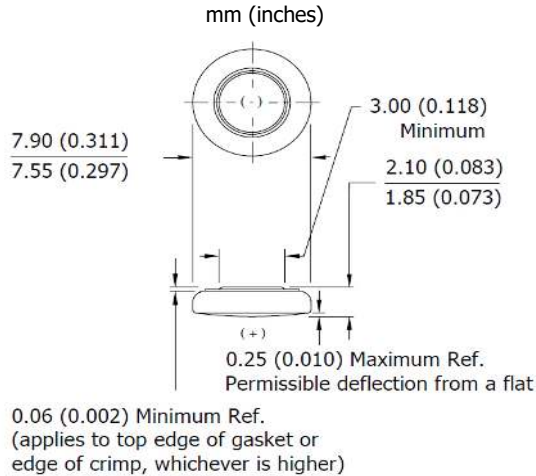

DESIGNED FOR USE ON CONTINUOUS LOW DRAIN

## General Information

<b>Chemical System:</b>	Silver Oxide (Zn/Ag <sub>2</sub> O)
<b>Designation:</b>	ANSI-1158SO, IEC-SR58
<b>Nominal Voltage:</b>	1.55 Volts
<b>Typical Capacity:</b>	26 mAh* (to 1.2 volts)
<b>Capacity Test:</b>	47K ohm continuous drain at 21°C
<b>Typical Weight:</b>	0.4 grams (0.06 oz.)
<b>Typical Volume:</b>	0.10 cubic centimeters (0.023 cubic inch)
<b>Impedance (40 Hz):</b>	15 to 35 ohms

\* Varies according to the applied load, temperature, and cutoff voltage.

## Cross Section

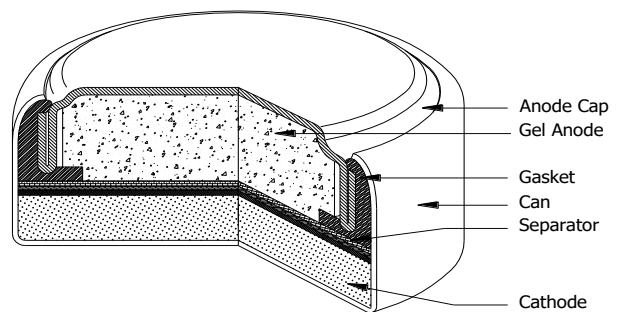

## Typical Discharge Characteristics

Typical Performance at 21°C (70°F)

**Schedule:** Continuous  
**Typical Drain @1.57V:**  
 0.033 milliamperes  
**Load:** 47K ohm

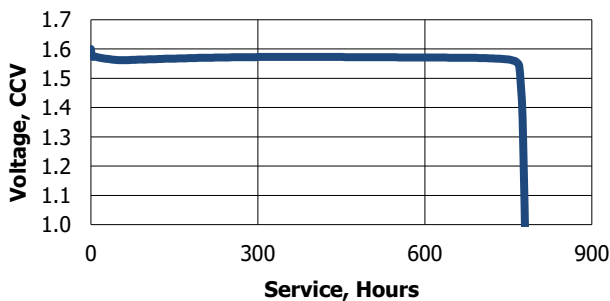

Schedule	Typical Drains at 1.55V (milliamperes)	Load (ohm)	Cutoff (hours)
Continuous	0.033	47K	777

## Temperature Characteristics

Typical Performance at Low Discharge rates

### Service Effects

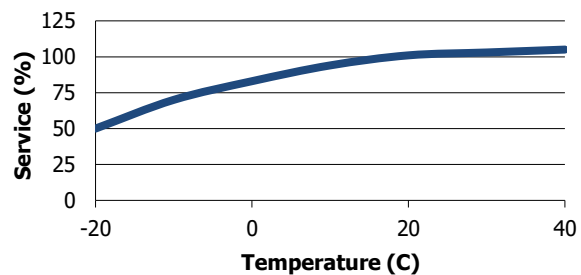

### Storage Effects

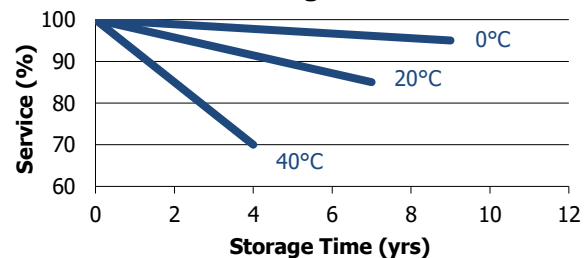

## Important Notice

This datasheet contains typical information specific to products manufactured at the time of its publication.  
**Contents herein do not constitute a warranty and are for reference only.**