

PAGE 1/2	ISSUE 18-08-15A	SERIES N	PART NUMBER 4501-9543-009
----------	-----------------	----------	---------------------------

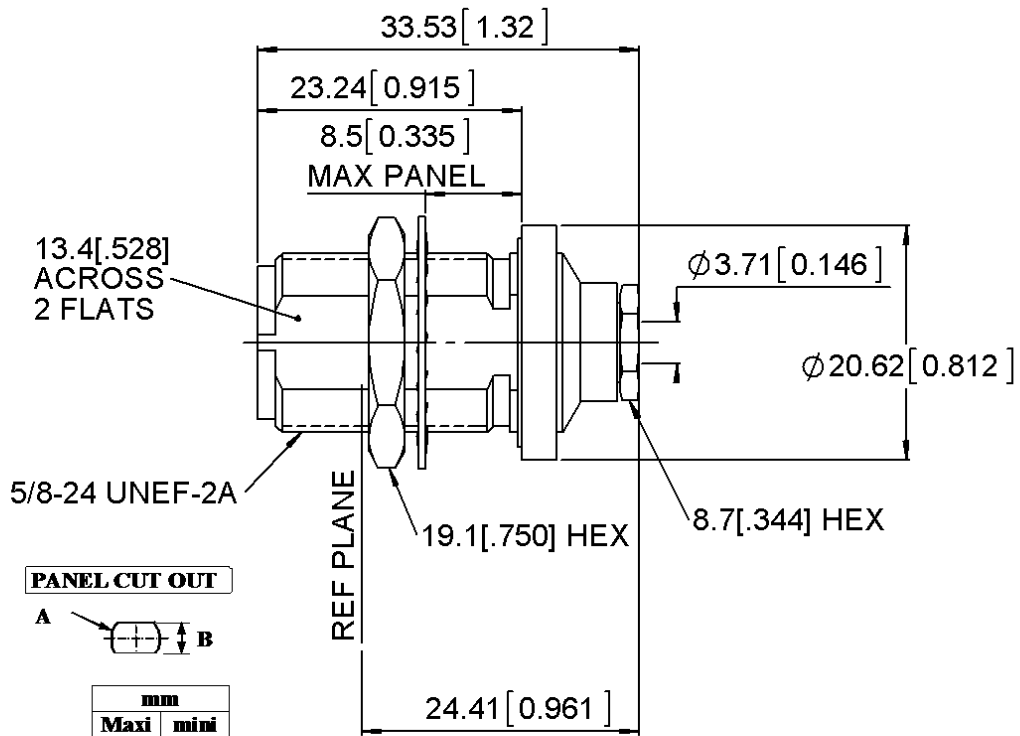

PANEL CUT OUT

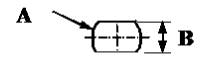

	mm	
	Maxi	mini
A	16	15.9
B	13.7	13.6

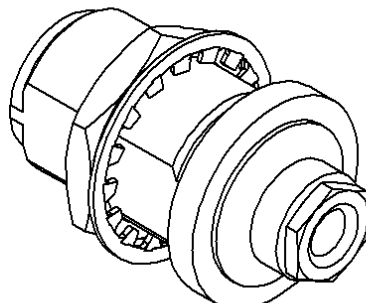
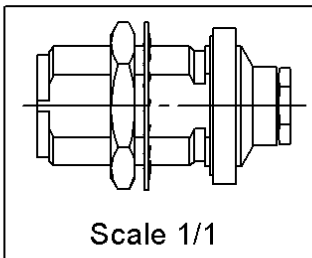

All dimensions are in mm.

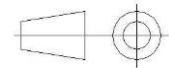

COMPONENTS	MATERIALS	PLATING (µm)
Body	STAINLESS STEEL	PASSIVATED
Center contact	BERYLLIUM COPPER	GOLD OVER NICKEL
Outer contact		
Insulator	PTFE	
Gasket	SILICONE RUBBER	
Others parts	BRASS	NICKEL
-	-	-
-	-	-

PAGE 2/2	ISSUE 18-08-15A	SERIES N	PART NUMBER 4501-9543-009
----------	-----------------	----------	---------------------------

PACKAGING

Standard	Unit	Other
1	Contact us	Contact us

ELECTRICAL CHARACTERISTICS

Impedance	50	Ω
Frequency	0-18	GHz
VSWR	1.2 + 0.0000	x F(GHz) Maxi
Insertion loss	.10	\sqrt{F} (GHz) dB Maxi
RF leakage	- (90)	- F(GHz)) dB Maxi
Voltage rating	500	Veff Maxi
Dielectric withstanding voltage	1500	Veff mini
Insulation resistance	5000	M Ω mini

MECHANICAL CHARACTERISTICS

Center contact retention		
Axial force – Mating End	27	N mini
Axial force – Opposite end	27	N mini
Torque	NA	N.cm mini
Recommended torque		
Mating	NA	N.cm
Panel nut	500	N.cm
Clamp nut	200	N.cm
A/F clamp nut	8.7000	mm
Mating life	500	Cycles mini
Weight	45.8200	g

ENVIRONMENTAL

Operating temperature	-40/+125	$^{\circ}\text{C}$
Hermetic seal	NA	Atm.cm3/s
Panel leakage	IP67	

SPECIFICATION

CABLE ASSEMBLY

Stripping	a	b	c	d	e	f
mm	0	0	0	0	0	0

Assembly instruction: **AIS-234-B124**

Recommended cable(s)
KS 2
RG 402

Characteristics indicated on this data sheet are those that can be achieved with the highest performance cable. Intrinsic limitations of the cable may diminish the performance of the assembly

Cable retention

- pull off	270	N mini
- torque	40	N.cm

TOOLING

Part Number	Description	Hexagon
.	.	.

OTHER CHARACTERISTICS