

PART NUMBER	REVISION	DESCRIPTION	FEED TYPE
2266535-2	C	FINE CRIMP HEIGHT ADJUST	PNEUMATIC
7-2266535-2	C	PNEUMATIC AND CRIMP TOOLING KIT	PNEUMATIC
7-2266535-7	A	CRIMP TOOLING KIT	-

ATLANTIC VERSION TERMINATOR INTERFACE ADAPTER

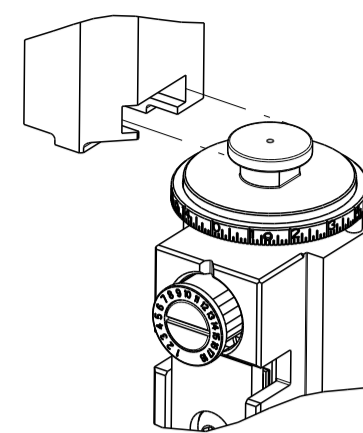

APPLICATOR DATA		
CRIMP	SIZE	TYPE
WIRE	2.03 mm [.080]	F
INSUL	6.35 mm [.250]	O

APPLICATOR INSTRUCTIONS
408-35042

TERMINAL DATA: TE TERMINAL		TE CRIMP SPECIFICATION	
TERMINAL NAME: TAB 5.8 X 0.8			
WIRE STRIP LENGTH		INSULATION DIAMETER RANGE	
4.55-5.31 mm [.179-.209 IN]		∅ 1.4 - 2.1mm	
TERMINAL APPLICATION SPECIFICATION	114-18052		
TERMINALS APPLIED			
TE TERMINAL	TE TERMINAL	TE SEAL	CABLE DIAMETER
2-962917-2	2-962917-1	963243-1	∅ 1.4 - 2.1mm
1-962917-2	1-962917-1		

WIRE SIZE	CRIMP HEIGHT mm [INCH]	CRIMP HEIGHT REFERENCE SETTING
1.00mm2	1.56 +/- 0.05 [.061 +/- .002]	4.4
0.75mm2	1.47 +/- 0.05 [.058 +/- .002]	5.2
0.50mm2	1.38 +/- 0.05 [.054 +/- .002]	6.2

- 1. RECOMMENDED SPARE PARTS
- 2. REFER TO SUPPLIED INSTRUCTION SHEET FOR CLEANING, LUBRICATION AND STORAGE OF APPLICATOR.
- 3. APPLY PART NUMBER 2-23419-6 LOCTITE TO THREADS OF ITEM 242.
- 4. CRIMP HEIGHT REFERENCE SETTING WAS THE SETTING USED WHEN THE APPLICATOR WAS QUALIFIED AT THE FACTORY. ADJUSTMENT MAY BE NECESSARY WHEN RUNNING APPLICATOR IN THE FIELD.
- 5. TERMINAL PITCH NOT COMPATIBLE WITH MECHANICAL FEED.
- 6. THIS APPLICATOR APPLIES TERMINAL WITH A SEAL.
- 7. APPLY TORO-SEAL IN ALLEN SOCKET TO FILL HOLE AFTER FLAT HD HAS BEEN ADJUSTED TO CORRECT HEIGHT AT QUALIFICATION. APPLY #1-23419-5 LOC-TITE TO THREADS.
- 8. UNLESS SPECIFIED OTHERWISE TORQUE VALUES SHALL BE USED PER DOCUMENT, 101-35000.

***WARNING**
ON INSTALLATION, SET WIRE DISC TO CRIMP HEIGHT REFERENCE SETTING FOR LARGEST WIRE SIZE. CRIMP HEIGHT REFERENCE SETTINGS GREATER THAN THE VALUE SHOWN MAY CAUSE DAMAGE TO THE CRIMP TOOLING, REFER TO THE INSTRUCTION SHEET FOR PROPER SETUP AND ADJUSTMENTS.

LOC	DIST	REVISIONS					
A	66	P	LTN	DESCRIPTION	DATE	OWN	APVD
		A		RELEASED	07JAN2015	MR	TE
		B		ECR-18-015356	26SEP2018	JAH	CT
		C		ECR-19-009012	08JUN2019	TB	TE

-	1	1	1803078-3	SPACER, PRECISION	259
-	1	1	2119641-1	FEED CAM, AIR FEED	248
-	1	1	2119082-4	CAM, SNAIL, INSULATION ADJUSTMENT	244
-	1	1	2079764-1	WASHER, WAVE SPRING, CREST-TO-CREST	243
-	1	1	2119083-1	RETAINER, INSULATION DIAL	242
-	1	1	7-18023-7	SCR, SKT HD CAP M3 X 4.0	241
-	1	1	2844940-1	AIR FEED MODULE	238
-	REF	REF	994970-2	COUNTER, MAGNETIC	164
-	1	1	455888-2	SPACER, CRIMPER	120
-	1	1	2844908-1	SCREW, LOCKING	99
-	1	1	2844907-1	POST, LOCKING	98
-	1	1	455888-5	SPACER, CRIMPER	82
-	2	2	2079383-4	SCR, BHSC, RoHS (M4 X 8)	79
-	1	1	1803096-1	EXTENSION PLATE	78
-	1	1	1803607-3	DOCUMENTATION PACKAGE	71
-	1	1	2119791-9	DEPRESSOR, WIRE	70
-	1	1	2119943-1	WASHER, SPACER	69
-	1	1	2119740-1	TAG IDENTIFICATION	67
-	2	2	2168078-1	SCREW, DRIVE, RH, RoHS, 2 x .188	66
-	1	1	2168083-2	SCR, SKT HD CAP, RoHS, M4 X 8.0	60
-	1	1	5-18022-5	SCR, HEX HD CAP, M4 X 6.0	59
-	1	1	985575-3	SCR, FLT SKT HD CAP M3 X 10.0	57
-	1	1	1338683-8	FEED PAWL	56
-	4	4	2168083-3	SCR, SKT HD CAP, RoHS, M4 X 12.0	54
-	2	2	1-2168083-0	SCR, SKT HD CAP, RoHS, M4 X 10	53
-	1	1	5018030-1	NUT, HEX, REG, RoHS, M3	52
-	1	1	1-811242-0	BUMPER, HOLD DOWN	51
-	1	1	690753-2	SPACER, TONKER	50
-	1	1	18023-9	SCR, SKT HD CAP M4 X 6.0	49
-	1	1	1803583-9	APPLICATOR BASIC ASSEMBLY, SF	46
-	1	1	1803515-2	RAM ASSEMBLY, SF ATLANTIC	44
-	1	1	1803602-2	SCR, BHSC, RoHS (M8 X 40)	41
-	1	1	1-1752356-2	SUPPORT, TERMINAL	34
-	2	2	2079383-5	SCR, BHSC, RoHS (M4 X 20)	33
-	2	2	2-2844962-3	SPACER, CYLINDRICAL, STRIP GUIDE	30
-	1	1	2844992-2	ASSEMBLY, STRIP GUIDE	29
-	1	1	455888-3	SPACER, CRIMPER	28
-	1	1	1320928-6	STRIP GUIDE	24
-	1	1	2168083-2	SCR, SKT HD CAP, RoHS, M4 X 8.0	21
-	2	2	1-18028-2	WASHER, FLAT, REG M4	20
-	1	1	2119533-1	STRIPPER, SIDE FEED	19
-	1	1	2119806-1	INSERT, SHEAR	13
-	1	1	3-22280-3	SPRING, COMPRESSION	12
-	1	1	1-356885-4	STOP, SHEAR	11
-	1	1	2119805-1	SHEAR HOLDER, FRONT	10
-	1	1	1-318707-2	FLOATING SHEAR, FRONT	9
-	1	2	1-1803054-2	ANVIL, COMBINATION	8
-	-	-	-	-	7
-	-	-	-	-	6
-	1	1	2-2119781-4	DEPRESSOR, SHEAR	5
-	1	1	238011-9	BLOCK, CRIMPER SPACER	4
-	1	2	5-1803018-0	CRIMPER, INSULATION O	3
-	1	1	1-455888-5	SPACER, CRIMPER	2
-	1	2	5-456405-6	CRIMPER, WIRE PREMIUM	1

ATLANTIC VERSION
Shown on sheets 1 of 4 & 2 of 4
(Pacific version shown on sheets 3 of 4 & 4 of 4)

DIMENSIONS:		TOLERANCES UNLESS OTHERWISE SPECIFIED:		MATERIAL:		FINISH:	
mm	0 PLC ±	1 PLC ±	2 PLC ±	3 PLC ±	4 PLC ±	ANGLES	FINISH

OWN	CHK	Y. YIN	APVD	U. GUO	PRODUCT SPEC	APPLICATION SPEC	SIZE	CAGE CODE	DRAWING NO	RESTRICTED TO
J. HOU	210TC2014	210TC2014	210TC2014	210TC2014			A1	00779	2266535	

Customer Accessible Production Drawing SCALE 1:2 SHEET 1 OF 4 REV C

LOC	DIST	REVISIONS					
		P	LTN	DESCRIPTION	DATE	DWN	APVD
A	66	-	-	SEE SHEET 1	-	-	-

FEED TYPE

PNEUMATIC

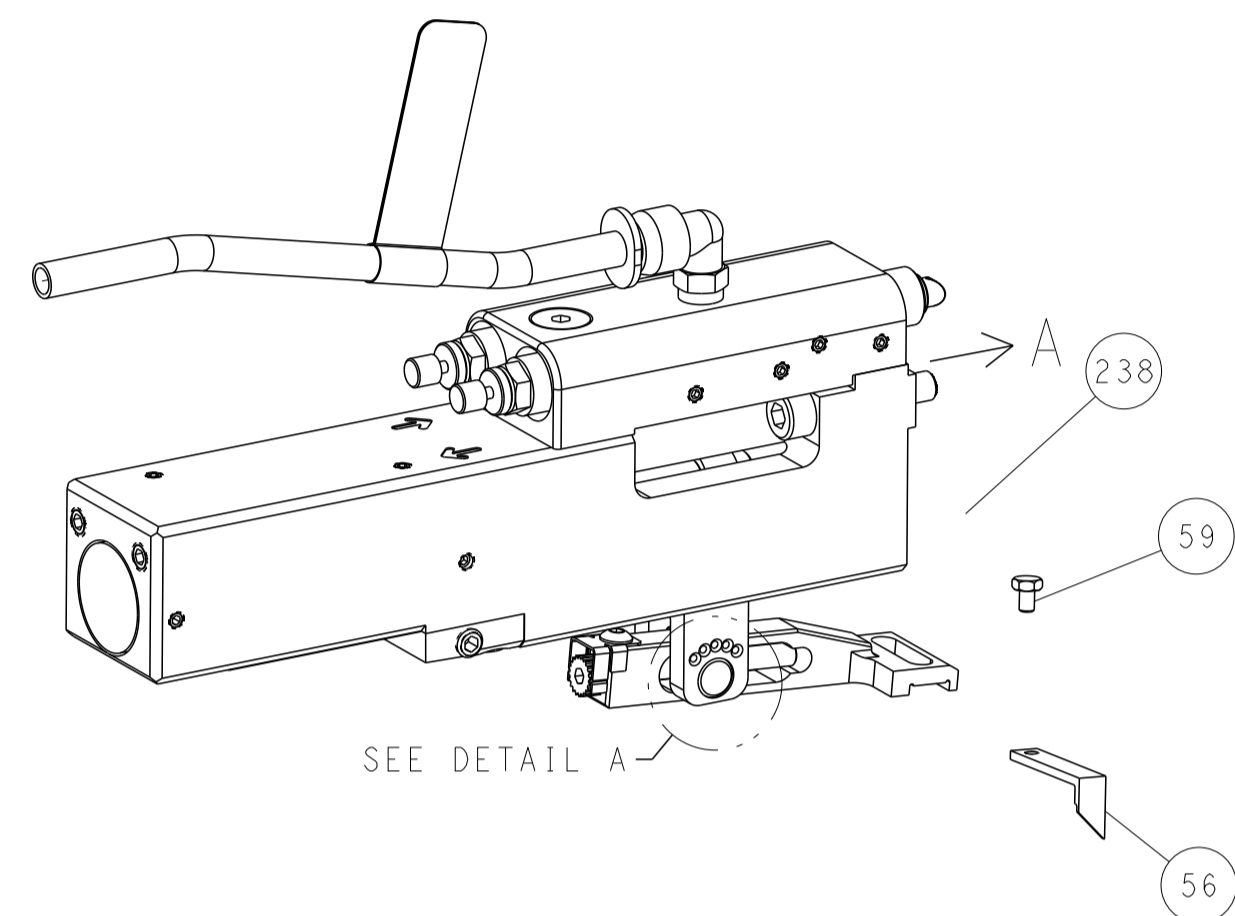

SEE DETAIL A

FEED SPRING SETTING POSITION (SHOWN FROM REAR SIDE)

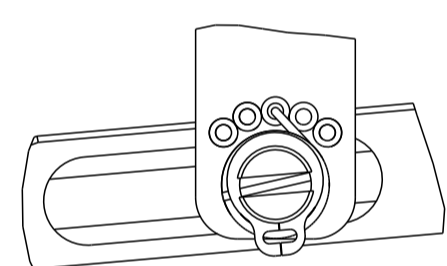

DETAIL A

CAM POSITION

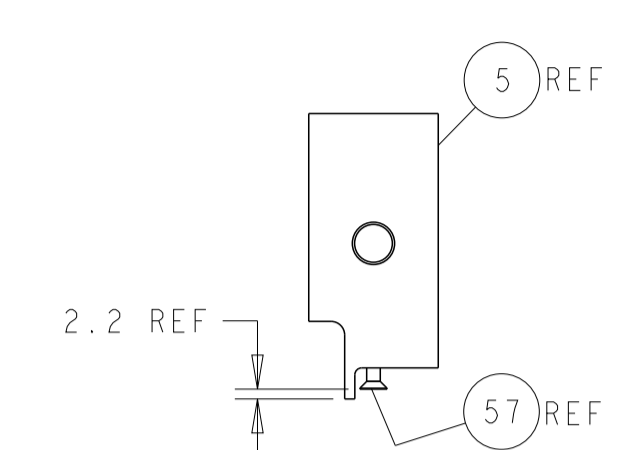
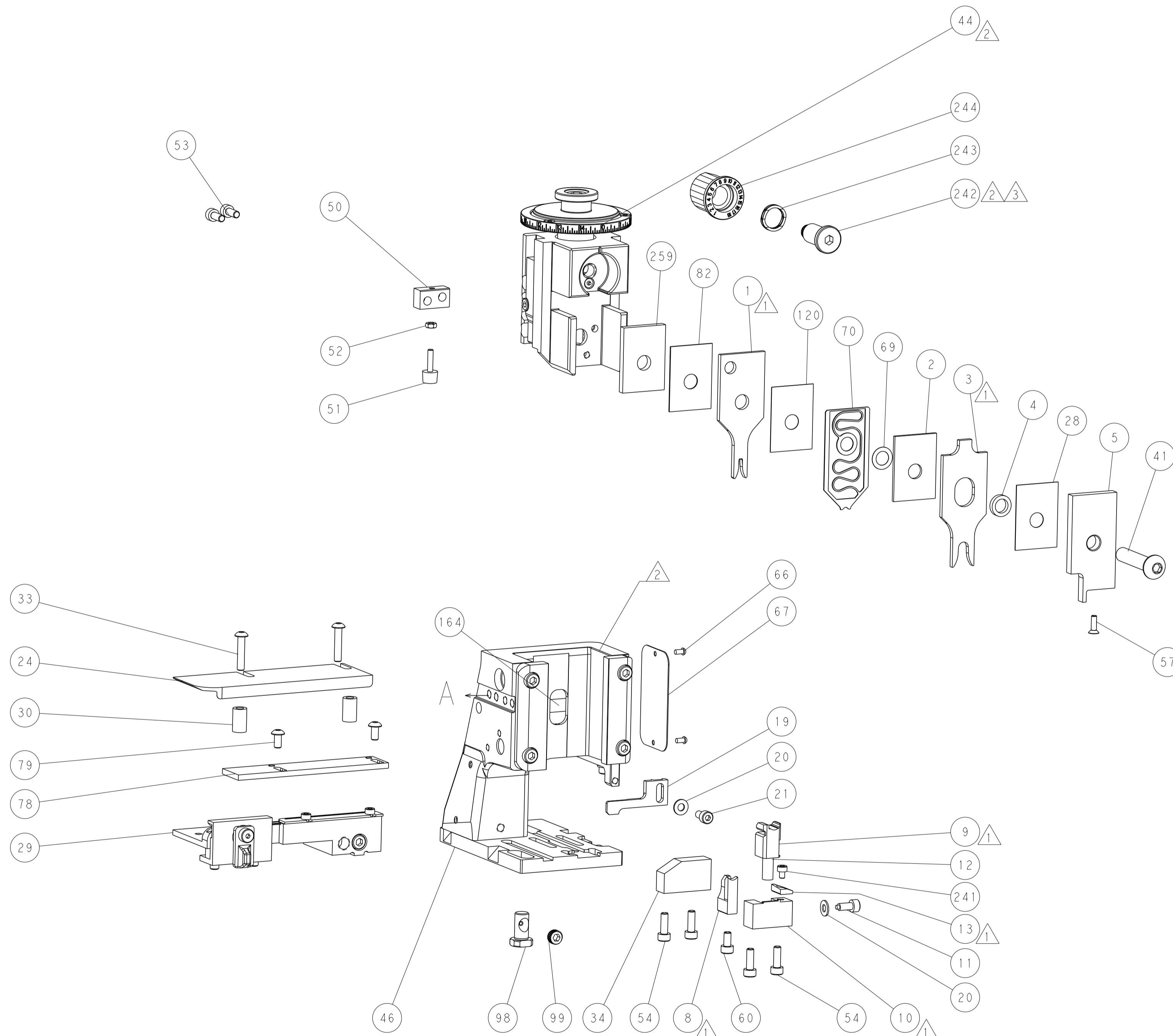
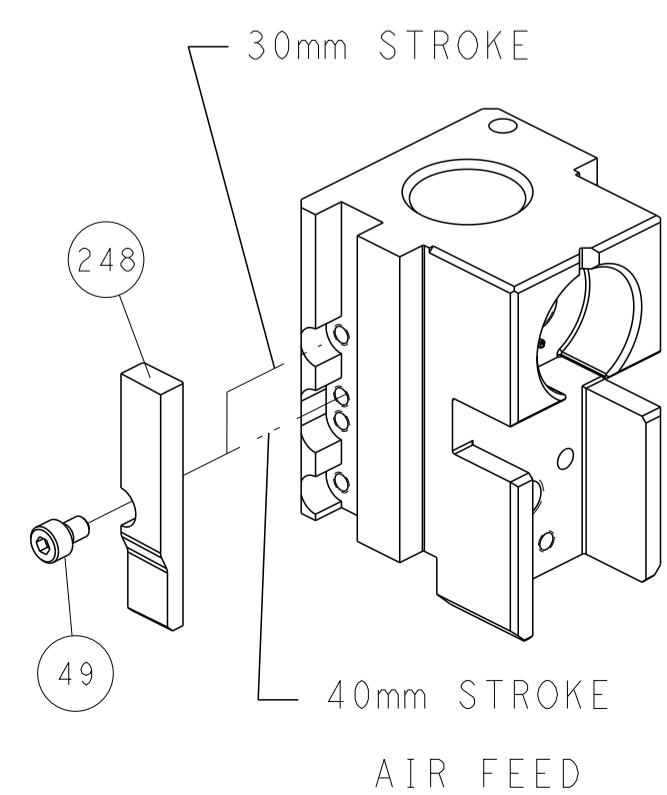

SHEAR DEPRESSOR DETAIL

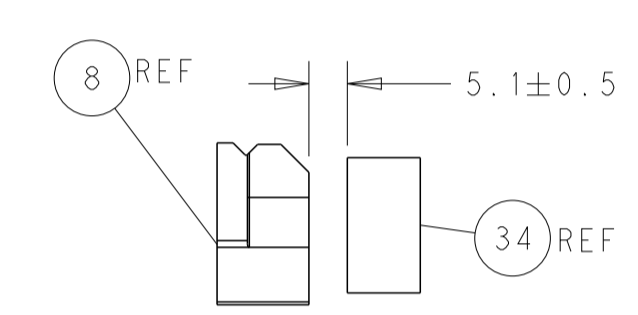

TERMINAL SUPPORT LOCATION

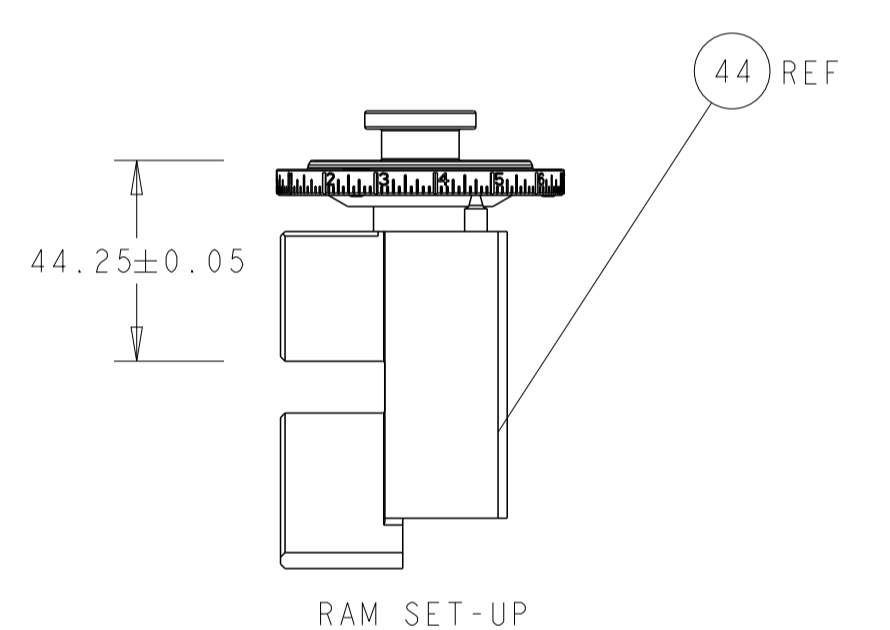

RAM SET-UP

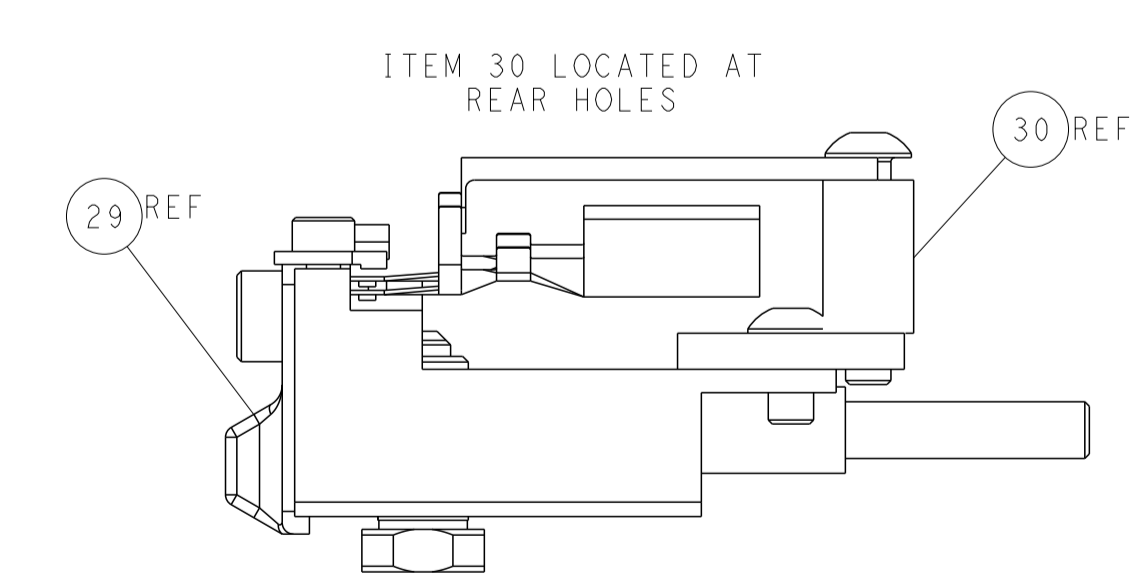

FEED TRACK POSITION GUIDE BY INSULATION BARREL

ATLANTIC VERSION
 Shown on sheets 1 of 4 & 2 of 4
 (Pacific version shown on sheets 3 of 4 & 4 of 4)

DIMENSIONS: mm 		TOLERANCES UNLESS OTHERWISE SPECIFIED: 0 PLC ± 1 PLC ± 2 PLC ± 3 PLC ± 4 PLC ± ANGLES ± FINISH ±		DWN J.HOU 210TC2014 CHK Y.YIN 210TC2014 APVD H.GUO 210TC2014 PRODUCT SPEC APPLICATION SPEC SIZE CAGE CODE DRAWING NO RESTRICTED TO A1 00779 C=2266535 Customer Accessible Production Drawing SCALE 1:2 SHEET 2 OF 4 REV C	
MATERIAL:				NAME: Ocean Side Feed Applicator TE Connectivity Harrisburg, PA 17105-3608	

PART NUMBER	REVISION	DESCRIPTION	FEED TYPE
2-2266535-2	C	FINE CRIMP HEIGHT ADJUST	PNEUMATIC
7-2266535-7	A	CRIMP TOOLING KIT	-

PACIFIC VERSION TERMINATOR
 INTERFACE ADAPTER



APPLICATOR DATA		
CRIMP	SIZE	TYPE
WIRE	2.03 mm [.080]	F
INSUL	6.35 mm [.250]	O
APPLICATOR INSTRUCTIONS 408-35042		

TERMINAL DATA: TE TERMINAL		TE CRIMP SPECIFICATION	
TERMINAL NAME: TAB 5.8 X 0.8			
WIRE STRIP LENGTH	INSULATION DIAMETER RANGE		
4.55-5.31 mm [1.79-.209 IN]	∅	△6	
TERMINAL APPLICATION SPECIFICATION	114-18052	-	-
TERMINALS APPLIED △5			
TE TERMINAL	TE TERMINAL	TE SEAL	TE SEAL
2-962917-2	2-962917-1	963243-1	
1-962917-2	1-962917-1		

WIRE SIZE	CRIMP HEIGHT mm [INCH]	CRIMP HEIGHT REFERENCE SETTING
1.00mm2	1.56+/-0.05 [1.061+/-0.002]	4.4
0.75mm2	1.47+/-0.05 [1.058+/-0.002]	5.2
0.50mm2	1.38+/-0.05 [1.054+/-0.002]	6.2

- △1 RECOMMENDED SPARE PARTS
- △2 REFER TO SUPPLIED INSTRUCTION SHEET FOR CLEANING, LUBRICATION AND STORAGE OF APPLICATOR.
- △3 APPLY PART NUMBER 2-23419-6 LOCTITE TO THREADS OF ITEM 242.
- △4 CRIMP HEIGHT REFERENCE SETTING WAS THE SETTING USED WHEN THE APPLICATOR WAS QUALIFIED AT THE FACTORY. ADJUSTMENT MAY BE NECESSARY WHEN RUNNING APPLICATOR IN THE FIELD.
- △5 TERMINAL PITCH NOT COMPATIBLE WITH MECHANICAL FEED.
- △6 THIS APPLICATOR APPLIES TERMINAL WITH A SEAL.
- △7 APPLY TORQ-SEAL IN ALLEN SOCKET TO FILL HOLE AFTER FLAT HD HAS BEEN ADJUSTED TO CORRECT HEIGHT AT QUALIFICATION. APPLY #1-23419-5 LOC-TITE TO THREADS.
- 8. UNLESS SPECIFIED OTHERWISE TORQUE VALUES SHALL BE USED PER DOCUMENT, 101-35000.

***WARNING**
 ON INSTALLATION, SET WIRE DISC TO CRIMP HEIGHT REFERENCE SETTING FOR LARGEST WIRE SIZE. CRIMP HEIGHT REFERENCE SETTINGS GREATER THAN THE VALUE SHOWN MAY CAUSE DAMAGE TO THE CRIMP TOOLING, REFER TO THE INSTRUCTION SHEET FOR PROPER SETUP AND ADJUSTMENTS.

LOC	DIST	REVISIONS					
A	66	P	LTN	DESCRIPTION	DATE	OWN	APVD
-	-	-	-	SEE SHEET 1	-	-	-

-	1	1803078-3	SPACER, PRECISION	259	
-	1	2119082-4	CAM, SNAIL, INSULATION ADJUSTMENT	244	
-	1	2079764-1	WASHER, WAVE SPRING, CREST-TO-CREST	243	
△3	-	1	2119083-1	RETAINER, INSULATION DIAL	242
-	1	7-18023-7	SCR, SKT HD CAP M3 X 4.0	241	
-	1	2844940-1	AIR FEED MODULE	238	
-	REF	994970-2	COUNTER, MAGNETIC	164	
-	1	2119641-2	FEED CAM, AIR FEED	151	
-	1	2168083-8	SCR, SKT HD CAP, RoHS, M4 X 16	144	
-	4	2168083-9	SCR, SKT HD CAP, RoHS, M4 X 20	143	
-	1	1-1803583-0	APPLICATOR BASIC ASSEMBLY, SF	141	
-	1	1803516-2	RAM ASSEMBLY, SF PACIFIC	140	
-	1	455888-2	SPACER, CRIMPER	120	
-	1	2844908-1	SCREW, LOCKING	99	
-	1	2844907-1	POST, LOCKING	98	
-	1	455888-5	SPACER, CRIMPER	82	
-	2	2079383-4	SCR, BHSC, RoHS (M4 X 8)	79	
-	1	1803096-1	EXTENSION PLATE	78	
-	1	1803607-3	DOCUMENTATION PACKAGE	71	
-	1	2119791-9	DEPRESSOR, WIRE	70	
-	1	2119943-1	WASHER, SPACER	69	
-	1	2119740-1	TAG IDENTIFICATION	67	
-	2	2168078-1	SCREW, DRIVE, RH, RoHS, 2 x .188	66	
-	1	5-18022-5	SCR, HEX HD CAP, M4 X 6.0	59	
△7	-	1	985575-3	SCR, FLT SKT HD CAP M3 X 10.0	57
-	1	1338683-8	FEED PAWL	56	
-	2	1-2168083-0	SCR, SKT HD CAP, RoHS, M4 X 10	53	
-	1	5018030-1	NUT, HEX, REG, RoHS, M3	52	
-	1	1-811242-0	BUMPER, HOLD DOWN	51	
-	1	690753-2	SPACER, TONKER	50	
-	1	18023-9	SCR, SKT HD CAP M4 X 6.0	49	
-	1	1803602-2	SCR, BHSC, RoHS (M8 X 40)	41	
-	1	1-1752356-2	SUPPORT, TERMINAL	34	
-	2	2079383-5	SCR, BHSC, RoHS (M4 X 20)	33	
-	2	2-2844962-3	SPACER, CYLINDRICAL, STRIP GUIDE	30	
-	1	2844992-2	ASSEMBLY, STRIP GUIDE	29	
-	1	455888-3	SPACER, CRIMPER	28	
-	1	1320928-6	STRIP GUIDE	24	
-	1	2168083-2	SCR, SKT HD CAP, RoHS, M4 X 8.0	21	
-	2	1-18028-2	WASHER, FLAT, REG M4	20	
-	1	2119533-1	STRIPPER, SIDE FEED	19	
△1	-	1	2119806-1	INSERT, SHEAR	13
-	1	3-22280-3	SPRING, COMPRESSION	12	
-	1	1-356885-4	STOP, SHEAR	11	
△1	-	1	2119805-1	SHEAR HOLDER, FRONT	10
△1	-	1	1-318707-2	FLOATING SHEAR, FRONT	9
△1	1	1	7-1803054-2	ANVIL, COMBINATION	8
-	-	-	-	7	
-	-	-	-	6	
-	1	2-2119781-4	DEPRESSOR, SHEAR	5	
-	1	238011-9	BLOCK, CRIMPER SPACER	4	
△1	1	1	5-1803018-0	CRIMPER, INSULATION O	3
-	1	1	1-455888-5	SPACER, CRIMPER	2
△1	1	1	5-456405-6	CRIMPER, WIRE PREMIUM	1

PACIFIC VERSION
 Shown on sheets 3 of 4 & 4 of 4
 (Atlantic version shown on sheets 1 of 4 & 2 of 4)

DIMENSIONS:		TOLERANCES UNLESS OTHERWISE SPECIFIED:		DWG: J.HOU 210TC2014		CHK: Y.YIN 210TC2014		APVD: J.GUO 210TC2014		NAME: Ocean Side Feed Applicator	
mm	0 PLC ±	1 PLC ±	2 PLC ±	3 PLC ±	4 PLC ±	ANGLES ±	FINISH	SIZE: A1	CAGE CODE: 00779	DRAWING NO: C=2266535	RESTRICTED TO: -
MATERIAL: -								WEIGHT: -	Customer Accessible Production Drawing		SCALE: 1:2 SHEET 3 OF 4 REV C

LOC	DIST	REVISIONS					
A	66	P	LYN	DESCRIPTION	DATE	DWN	APVD
		-	-	SEE SHEET 1	-	-	-

FEED TYPE

PNEUMATIC

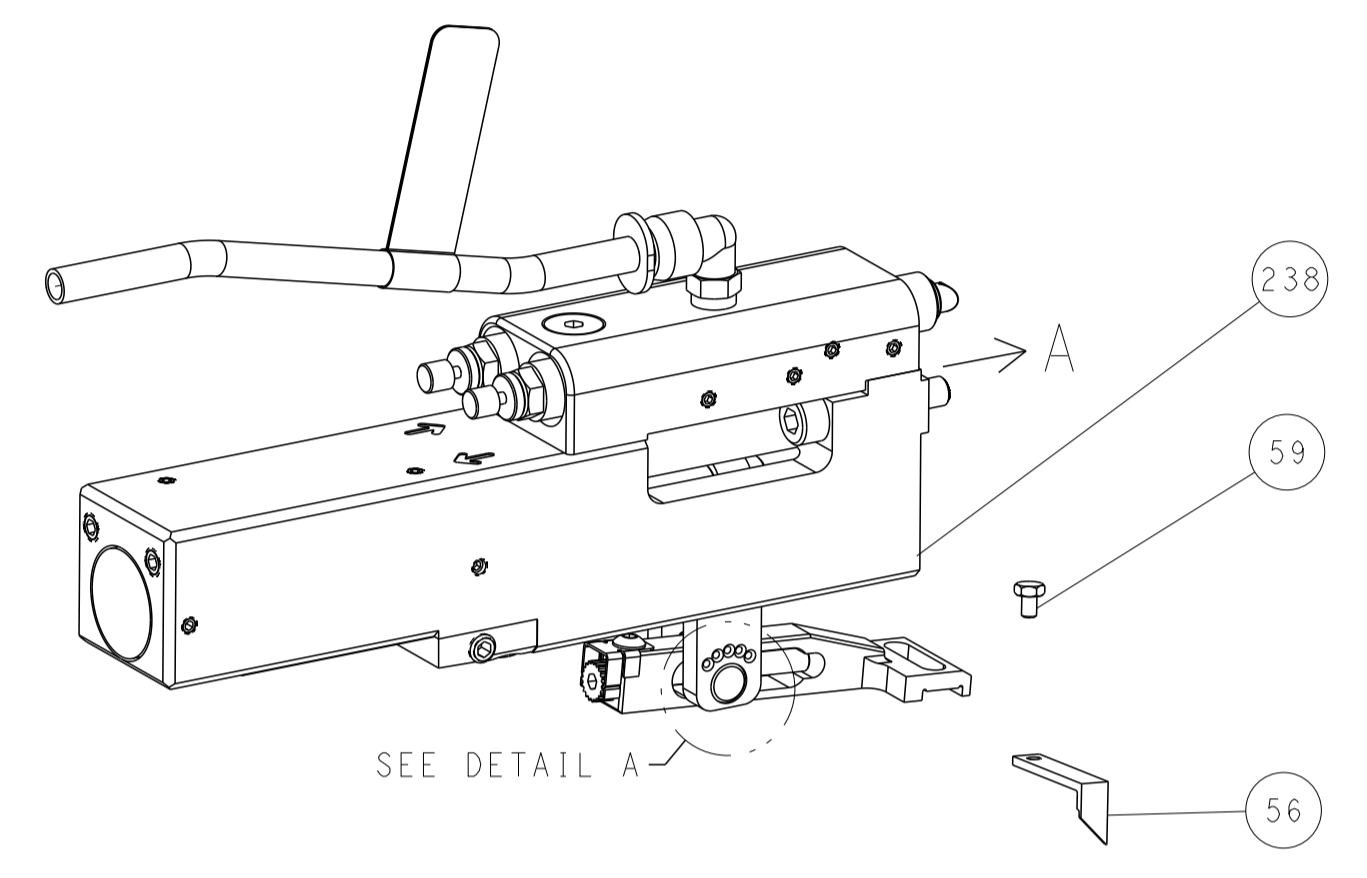

SEE DETAIL A

FEED SPRING SETTING POSITION (SHOWN FROM REAR SIDE)

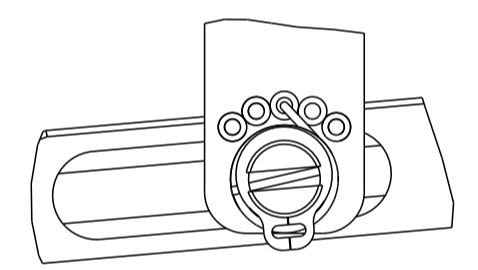

DETAIL A

CAM POSITION

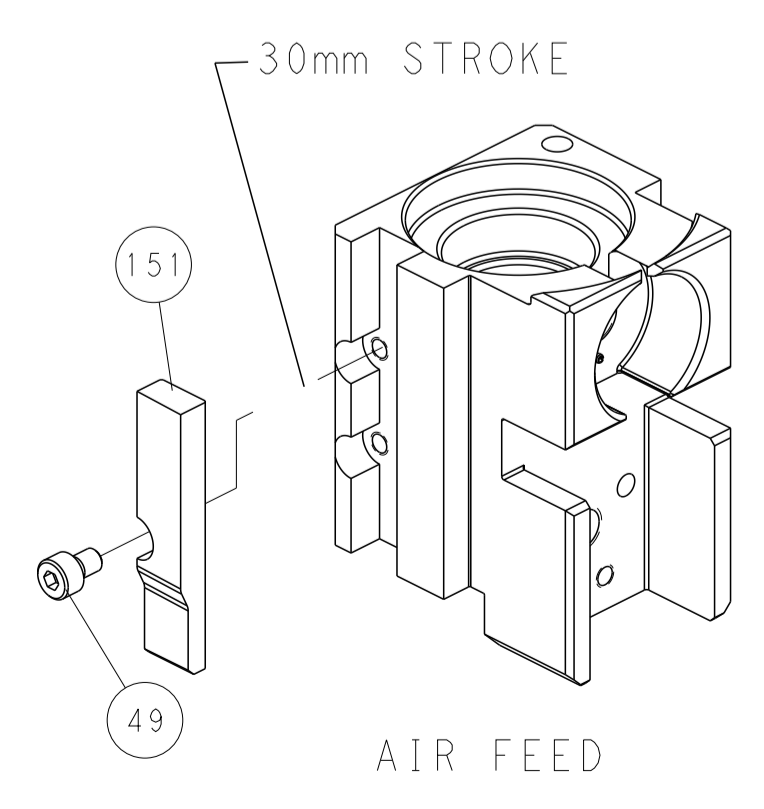

AIR FEED

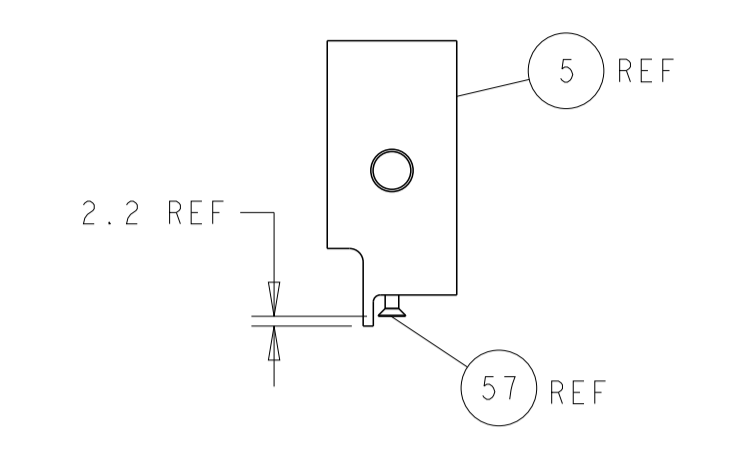
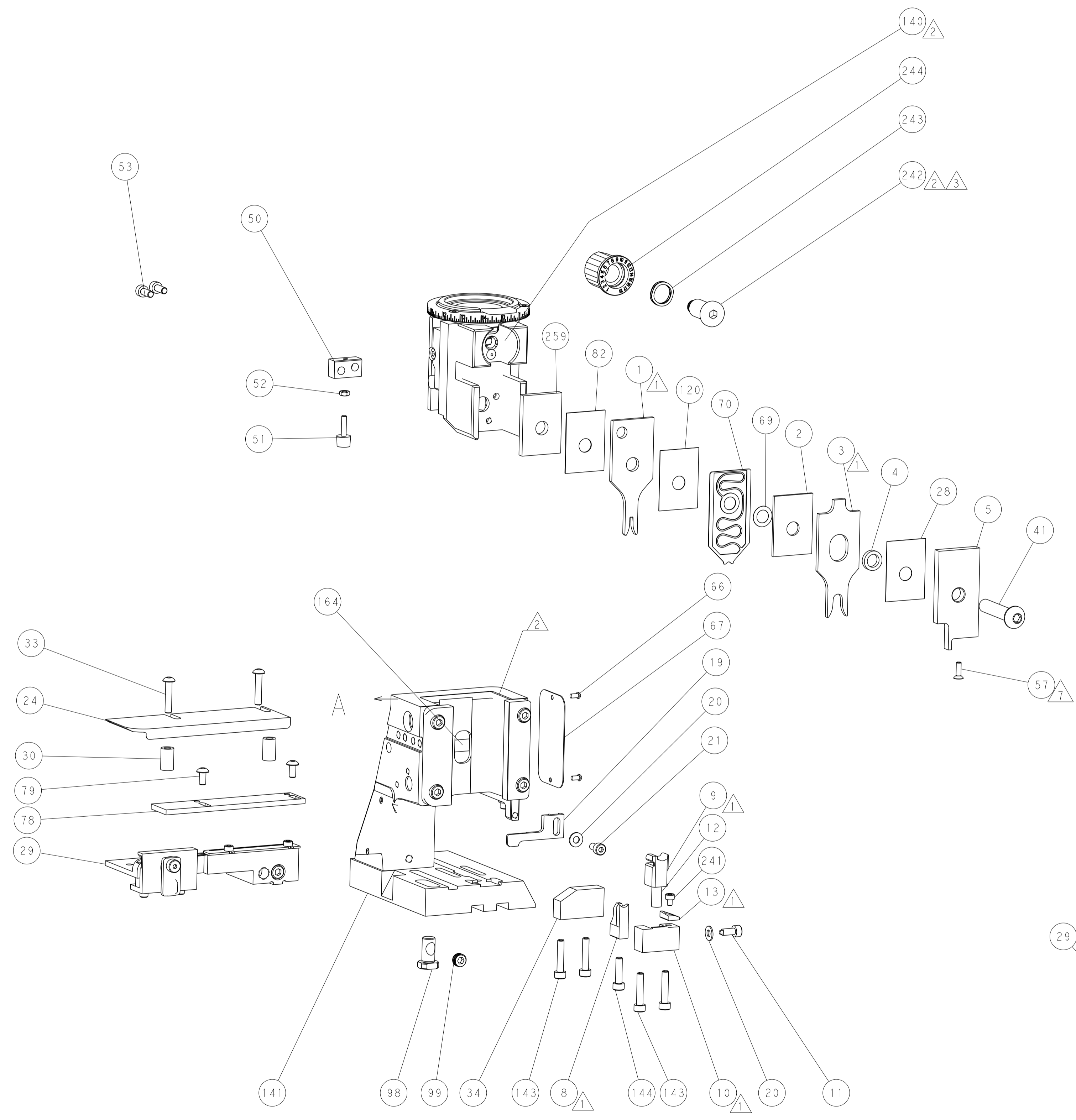

SHEAR DEPRESSOR DETAIL

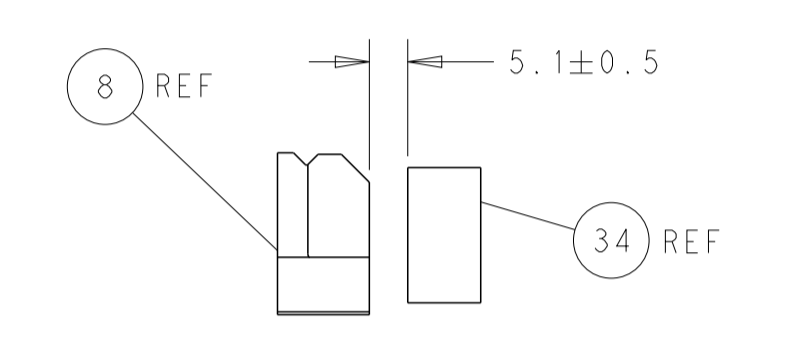

TERMINAL SUPPORT LOCATION

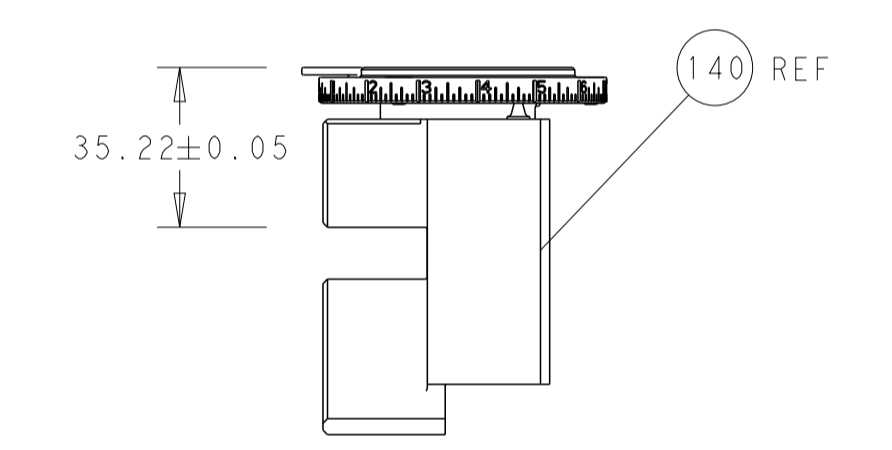

RAM SET-UP

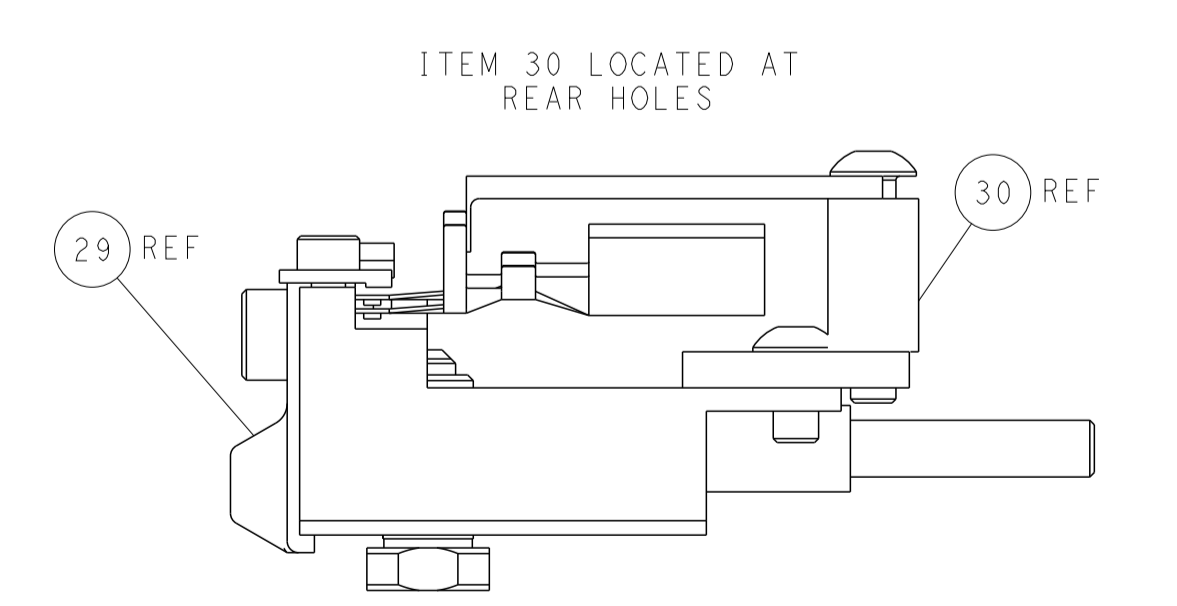

FEED TRACK POSITION
GUIDE BY INSULATION BARREL

PACIFIC VERSION
 Shown on sheets 3 of 4 & 4 of 4
 (Atlantic version shown on sheets 1 of 4 & 2 of 4)

<small>THIS DRAWING IS UNPUBLISHED. RELEASED FOR PUBLICATION BY TYCO ELECTRONICS CORPORATION. ALL RIGHTS RESERVED.</small>		DWN: J. HOU CHK: Y. YIN APVD: J. GUO	PRODUCT SPEC APPLICATION SPEC	NAME: Ocean Side Feed Applicator SIZE: A1 CAGE CODE: 00779 DRAWING NO: 210TC2014 SCALE: 1:2	DATE: - SHEET: 4 OF 4 REV: C
DIMENSIONS: mm TOLERANCES UNLESS OTHERWISE SPECIFIED: 0 PLC ± 1 PLC ± 2 PLC ± 3 PLC ± 4 PLC ± ANGLES ± MATERIAL: - FINISH: -	TOLERANCES UNLESS OTHERWISE SPECIFIED: 0 PLC ± 1 PLC ± 2 PLC ± 3 PLC ± 4 PLC ± ANGLES ± MATERIAL: - FINISH: -	PRODUCT SPEC APPLICATION SPEC	NAME: Ocean Side Feed Applicator SIZE: A1 CAGE CODE: 00779 DRAWING NO: 210TC2014 SCALE: 1:2	DATE: - SHEET: 4 OF 4 REV: C	DATE: - SHEET: 4 OF 4 REV: C