

Multi-Endpoint USB Peripheral Controller

FEATURES

- High Performance USB Peripheral Controller Engine
 - Integrated USB Transceiver
 - Serial Interface Engine (SIE)
 - 8051 Microcontroller (MCU)
 - Patented Memory Management Unit (MMU)
 - 4 Channel 8237 DMA Controller (ISADMA)
 - 4K Byte On Board USB Packet Buffer
 - Quasi-ISA Peripheral Interface
 - USB Bus Snooping Capabilities
 - GPIOs
- Complete USB Specification 1.1 Compatibility
 - Isochronous, Bulk, Interrupt, and Control Data Independently Configurable per Endpoint
 - Dynamic Hardware Allocation of -Packet Buffer for Virtual Endpoints
 - Multiple Virtual Endpoints (up to 16 TX, 16 RX Simultaneously)
 - Multiple Alternate Address Filters
 - Dynamic Endpoint Buffer Length Allocation (0-1280 Byte Packets)
- High Speed (12Mbps) Capability
- MMU and SRAM Buffer Allow Buffer Optimization and Maximum Utilization of USB Bandwidth
 - 128 Byte Page Size
 - 10 Pages Maximum per Packet
 - Up to 16 Deep Receive Packet Queue
 - Up to 5 Deep Transmit Packet Queue, per Endpoint
 - Hardware Generated Packet Header Records Each Packet Status Automatically
 - Simultaneous Arbitration Between MCU, SIE, and ISA DMA Accesses
- Extended Power Management
 - Standard 8051 "Stop Clock" Modes
 - Additional USB and ISA Suspend Resume Events
 - Internal 8MHz Ring Oscillator for Immediate Low Power Code Execution
 - 24, 16, 12, 8, 4, and 2 MHz PLL Taps For on the Fly MCU and DMA Clock Switching
 - Independent Clock/Power Management for SIE, MMU, DMA and MCU
- DMA Capability with ISA Memory
 - Four Independent Channels
 - Transfer Between Internal and External Memory
 - Transfer Between I/O and Buffer Memory
 - External Bus Master Capable
- External MCU Memory Interface
 - 1M Byte Code and Data Storage via 16K Windows
 - Flash, SRAM, or EPROM
 - Downloadable via USB, Serial Port, or ISA Peripheral
- Quasi-ISA Interface Allows Interface to New and "Legacy" Peripheral Devices
 - 1M ISA Memory Space via 4K MCU Window
 - 64K ISA I/O Space via 256 Byte MCU Window
 - 4 External Interrupt Inputs
 - 4 DMA Channels
 - Variable Cycle Timing
 - 8 Bit Data Path
- 5V or 3.3v Operation
- On Board Crystal Driver Circuit
- 128 Pin QFP Package

ORDERING INFORMATION

Order Number: USB97C100QFP
128 Pin QFP Package

GENERAL DESCRIPTION

The USB97C100 is a flexible, general purpose USB peripheral interface and controller ideally suited for multiple endpoint applications. The USB97C100 provides an ISA-like bus interface, which will allow virtually any PC peripheral to be placed at the end of a USB connection. Its unique dynamic buffer architecture overcomes the throughput disadvantages of existing fixed FIFO buffer schemes allowing maximum utilization of the USB connection's overall bandwidth. This architecture minimizes the integrated microcontroller's participation in the USB data flow, allowing back-to-back packet transfers to block oriented devices. The efficiency of this architecture allows floppy drives to coexist with other peripherals such as serial and parallel ports on a single USB link.

The USB97C100 allows external program code to be downloaded over the USB to allow easy implementation of varied peripheral USB Device Classes and combinations. This also provides a method for convenient field upgrades and modifications.

© STANDARD MICROSYSTEMS CORPORATION (SMSC) 2001



80 Arkay Drive
Hauppauge, NY 11788
(631) 435-6000
FAX (631) 273-3123

Standard Microsystems is a registered trademark of Standard Microsystems Corporation, and SMSC is a trademark of Standard Microsystems Corporation. Product names and company names are the trademarks of their respective holders. Circuit diagrams utilizing SMSC products are included as a means of illustrating typical applications; consequently complete information sufficient for construction purposes is not necessarily given. Although the information has been checked and is believed to be accurate, no responsibility is assumed for inaccuracies. SMSC reserves the right to make changes to specifications and product descriptions at any time without notice. Contact your local SMSC sales office to obtain the latest specifications before placing your product order. The provision of this information does not convey to the purchaser of the semiconductor devices described any licenses under the patent rights of SMSC or others. All sales are expressly conditional on your agreement to the terms and conditions of the most recently dated version of SMSC's standard Terms of Sale Agreement dated before the date of your order (the "Terms of Sale Agreement"). The product may contain design defects or errors known as anomalies which may cause the product's functions to deviate from published specifications. Anomaly sheets are available upon request. SMSC products are not designed, intended, authorized or warranted for use in any life support or other application where product failure could cause or contribute to personal injury or severe property damage. Any and all such uses without prior written approval of an Officer of SMSC and further testing and/or modification will be fully at the risk of the customer. Copies of this document or other SMSC literature, as well as the Terms of Sale Agreement, may be obtained by visiting SMSC's website at <http://www.smsc.com>.

SMSC DISCLAIMS AND EXCLUDES ANY AND ALL WARRANTIES, INCLUDING WITHOUT LIMITATION ANY AND ALL IMPLIED WARRANTIES OF MERCHANTABILITY, FITNESS FOR A PARTICULAR PURPOSE, TITLE, AND AGAINST INFRINGEMENT, AND ANY AND ALL WARRANTIES ARISING FROM ANY COURSE OF DEALING OR USAGE OF TRADE.

IN NO EVENT SHALL SMSC BE LIABLE FOR ANY DIRECT, INCIDENTAL, INDIRECT, SPECIAL, PUNITIVE, OR CONSEQUENTIAL DAMAGES, OR FOR LOST DATA, PROFITS, SAVINGS OR REVENUES OF ANY KIND; REGARDLESS OF THE FORM OF ACTION, WHETHER BASED ON CONTRACT, TORT, NEGLIGENCE OF SMSC OR OTHERS, STRICT LIABILITY, BREACH OF WARRANTY, OR OTHERWISE; WHETHER OR NOT ANY REMEDY IS HELD TO HAVE FAILED OF ITS ESSENTIAL PURPOSE; AND WHETHER OR NOT SMSC HAS BEEN ADVISED OF THE POSSIBILITY OF SUCH DAMAGES.

TABLE OF CONTENTS

FEATURES	1
GENERAL DESCRIPTION.....	2
PIN CONFIGURATION	4
DESCRIPTION OF PIN FUNCTIONS	5
BUFFER TYPE DESCRIPTIONS.....	7
FUNCTIONAL DESCRIPTION.....	9
Serial Interface Engine (SIE).....	9
Micro Controller Unit (MCU)	9
SIEDMA.....	9
Memory Management Unit (MMU) Register Description	9
ISADMA.....	9
Applications	10
TYPICAL SIGNAL CONNECTIONS	12
MCU MEMORY MAP	13
Code Space.....	13
Data Space.....	13
ISADMA Memory Map.....	13
MCU Block Register Summary.....	14
MMU Block Register Summary	15
SIE Block Register Summary	16
MCU REGISTER DESCRIPTION.....	17
MCU Runtime Registers.....	17
FIFO Status Registers.....	20
MCU Power Management Registers	24
MCU ISA Interface Registers	27
8237 (ISADMA) REGISTER DESCRIPTION	30
Memory Map.....	30
Runtime Registers.....	31
MEMORY MANAGEMENT UNIT (MMU) REGISTER DESCRIPTION	37
MMU Interface Registers.....	37
MMU FREE PAGES REGISTER.....	40
16 BYTE DEEP TX COMPLETION FIFO REGISTER	40
TX FIFO POP REGISTER.....	41
SERIAL INTERFACE ENGINE (SIE) REGISTER DESCRIPTION	45
Packet Header Definition.....	45
SIE Interface Registers	46
DC PARAMETERS	51
USB PARAMETERS.....	53
USB DC PARAMETERS	53
USB AC PARAMETERS.....	54
MECHANICAL OUTLINE.....	63
USB97C100 REVISIONS.....	64

PIN CONFIGURATION

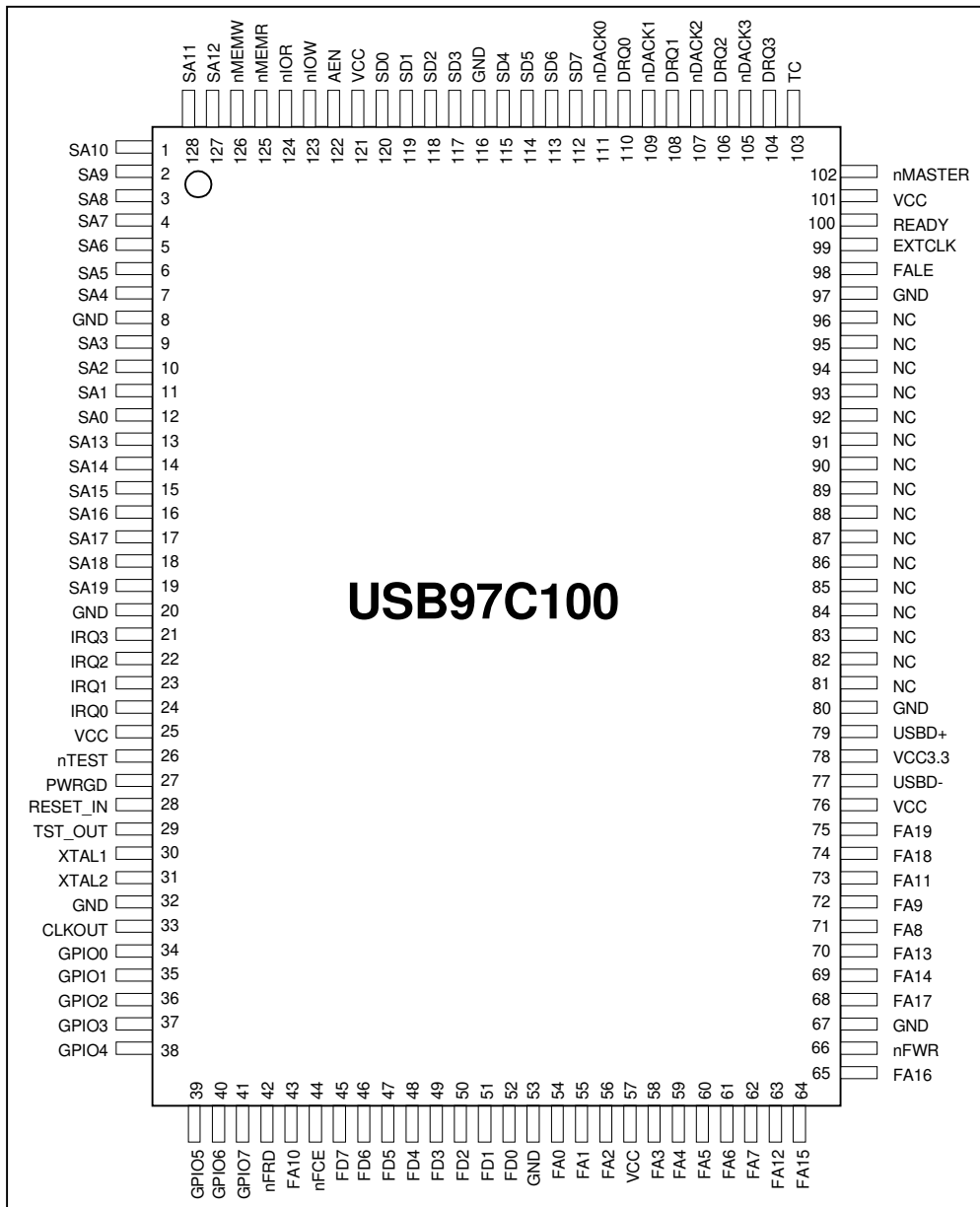

FIGURE 1 - PIN CONFIGURATION

DESCRIPTION OF PIN FUNCTIONS

Table 1 - USB97C100 Pin Configuration

QFP PIN NUMBER	SYMBOL	PIN DESCRIPTION	BUFFER TYPE
ISA INTERFACE			
100	READY	<i>Channel is ready when high. ISA memory or slave devices use this signal to lengthen a bus cycle from the default time. Extending the length of the bus cycle can only be done when the bus cycles are derived from the Internal DMA controller core. 8051 MCU generated Memory or I/O accesses cannot and will not be extended even if READY is asserted low by an external ISA slave device. The external slave device negates this signal after decoding a valid address and sampling the command signals (nLOW, nIOR, nMEMW, and nMEMR). When the slave's access has completed, this signal should be allowed to float high.</i>	IP
104, 106, 108, 110	DRQ[3:0]	DMA Request channels 3-0; active high. These signals are used to request DMA service from the DMA controller. The requesting device must hold the request signal until the DMA controller drives the appropriate DMA acknowledge signal (nDACK[3:0]).	I
105, 107, 109, 111	nDACK [3:0]	DMA Acknowledge channels 3-0; active low. These signals are used to indicate to the DMA requesting device that it has been granted the ISA bus.	O8
103	TC	DMA Terminal Count; active high. This signal is used to indicate that a DMA transfer has completed.	O8
19-13, 127-7, 9-12	SA[19:0]	System Address Bus These signals address memory or I/O devices on the ISA bus.	O8
112-115, 117-120	SD[7:0]	System Data Bus These signals are used to transfer data between system devices.	I/O8
122	AEN	Address Enable This signal indicates address validation to I/O devices. When low this signal indicates that an I/O slave may respond to addresses and I/O commands on the bus. This signal is high during DMA cycles to prevent I/O slaves from interpreting DMA cycles as valid I/O cycles.	O8
123	nLOW	I/O Write; active low. This signal indicates to the addressed ISA I/O slave to latch data from the ISA bus.	O8
124	nIOR	I/O Read; active low. This signal indicates to the addressed ISA I/O slave to drive data on the ISA bus.	O8
125	nMEMR	Memory read; active low This signal indicates to the addressed ISA memory slave to drive data on the ISA bus.	O8
126	nMEMW	Memory write; active low This signal indicates to the addressed ISA memory slave to latch data from the ISA bus.	O8

QFP PIN NUMBER	SYMBOL	PIN DESCRIPTION	BUFFER TYPE
102	nMASTER	External Bus master, active low This signal forces the USB97C100 to immediately tri-state its external bus, even if internal transactions are not complete. All shared ISA signals are tri-stated, except 8237 nDACKs, which can be used in gang mode to provide external bus-master handshaking. This pin must be used with some handshake mechanism to avoid data corruption.	IP
21-24	IRQ[3:0]	Interrupt Request 3-0; active high These signals are driven by ISA devices on the ISA bus to interrupt the 8051.	I
30	XTAL1/ Clock In	24MHz Crystal or clock input. This pin can be connected to one terminal of the crystal or can be connected to an external clock when a crystal is not used.	ICLKx
31	XTAL2	24MHz Crystal This is the other terminal of the crystal.	OCLKx
99	EXTCLK	Alternate clock to 8237 An external clock can be used for the internal 8237. This clock can be used to synchronize the 8237 to other devices.	ICLK
33	CLKOUT	Clock output. This clock frequency is the same as the 8051 running clock. This clock is stopped when the 8051 is stopped. Peripherals should not use this clock when they are expected to run when the 8051 is stopped. This clock can be used to synchronize other devices to the 8051.	O8
USB INTERFACE			
77, 79	USBD- USDB+	USB Upstream Connection signals These are two point-to-point signals and driven differentially.	IO-U
FLASH INTERFACE			
45-52	FD[7:0]	Flash ROM Data Bus These signals are used to transfer data between 8051 and the external FLASH.	IO8
75, 74, 68, 65, 64, 69, 70, 63, 73, 43, 72, 71, 62-58, 56-54	FA[19:0]	Flash ROM Address Bus These signals address memory locations within the FLASH.	O8
42	nFRD	Flash ROM Read; active low	O8
66	nFWR	Flash ROM Write; active low	O8
44	nFCE	Flash ROM Chip Select; active low	O8
98	FALE	Flash ROM address latch enable	O8
POWER SIGNALS			
25,57,76 101,121	VCC	+3.3V power or 5V	
78	VCC3.3	+3.3V power for USB	
8, 20, 32, 53, 67, 80, 97, 116	GND	Ground Reference	
MISCELLANEOUS			
41-34	GPIO[7:0]	General Purpose I/O. These pins can be configured as inputs or outputs under software control.	I/O16

QFP PIN NUMBER	SYMBOL	PIN DESCRIPTION	BUFFER TYPE
27	PWRGD	Active high input. This signal is used to indicate to that chip that a good power level has been reached. When inactive/low, all pins are Tri-stated except TST_OUT and a POR is generated.	I
28	RESET_IN	Power on reset; active high This signal is used by the system to reset the chip. It also generates an internal POR.	I
29	TST_OUT	AND tree output This signal is used for testing the chip via an internal AND tree.	O8
26	nTEST	Test input This signal is a manufacturing test pin. User can pull it high or leave it unconnected.	IP
[96:81]	NC	No connect	

BUFFER TYPE DESCRIPTIONS

Table 2 - USB97C100 Buffer Type Description

BUFFER	DESCRIPTION
I	Input (no pull-up)
IP	Input 90 μ A with internal pull-up
O8	Output with 8mA drive
I/O8	Input/output with 8mA drive
I/O16	Input/output with 16mA drive
O24	Output, 24mA sink, 12mA source.
I/ODP24	Input/Output drain , 24mA sink, 12mA source with 90 μ A pull-up
ICLKx	XTAL clock input
OCLKx	XTAL clock output
ICLK	Clock input (TTL levels)
I/O-U	Defined in USB specification; uses VCC3.3

Note: These DC Characteristics/drive strengths apply to 5V operation only. See the DC Characteristics section for additional details.

USB97C100 BLOCK DIAGRAM

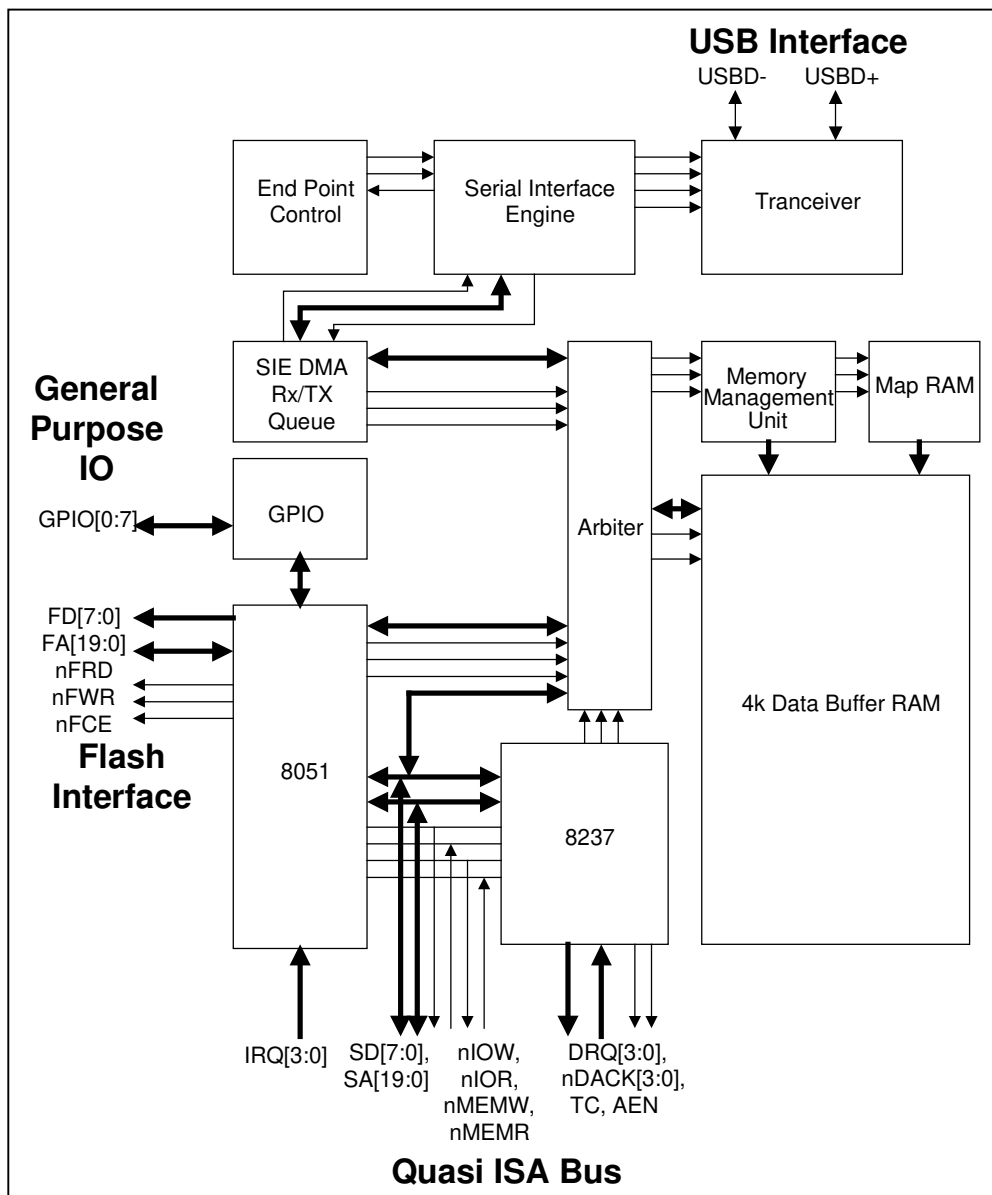

FIGURE 2 - BLOCK DIAGRAM

FUNCTIONAL DESCRIPTION

The USB97C100 incorporates a USB Serial Interface Engine (SIE), 8051 Microcontroller Unit (MCU), Serial Interface Engine DMA (SIEDMA), a programmable 8237 ISA bus DMA controller (ISADMA), 4K bytes of SRAM for data stream buffering, and a patented MMU (Memory Management Unit) to dynamically manage buffer allocation. The semi-automatic nature of the SIEDMA, ISADMA, and MMU blocks frees the MCU to provide enumeration, protocol and power management. A bus arbiter integrated into the MMU assures that transparent access between the SIEDMA, ISADMA, and MCU to the SRAM occurs.

Serial Interface Engine (SIE)

The SIE is a USB low-level protocol interpreter. The SIE controls the USB bus protocol, packet generation/extraction, parallel-to-serial/serial-to-parallel conversion, CRC coding/decoding, bit stuffing, and NRZI coding/decoding.

The SIE can be dynamically configured as having any combination of 0-16 transmit, and 0-16 receive endpoints, for up to 4 independent addresses. There are 3 alternate and one local address. The alternate addresses, for example, can be used for Hub addresses. The SIE can also "Receive All Addresses" for bus snooping.

Micro Controller Unit (MCU)

The 8051 embedded controller is a static CMOS MCU which is fully software compatible with the industry standard Intel 80C51 micro-controller. All internal registers of the USB97C100 blocks are mapped into the external memory space of the MCU.

A detailed description of the microcontroller's internal registers and instruction set can be found in the "USB97C100 Programmer's Reference Guide".

SIEDMA

This is a simplified DMA controller, which automatically transfers data between SIE and SRAM via MMU control. The SIEDMA appends a status header containing frame number, endpoint, and byte count to each incoming packet before notifying the MCU of its arrival. This block's operation is transparent to the firmware.

Memory Management Unit (MMU) Register Description

This patented MMU consists of a 4k buffer RAM which is allocated in 32 pages of 128 bytes. Packets can be allocated with up to 10 pages each (1280 bytes). The buffer can therefore concurrently hold up to 32 packets with a 64 byte payload. For isochronous pipes, it can hold 3 packets with a 1023 byte payload each, and still have room for two more 64 byte packets.

This block supports 16 independent transmit FIFO queues (one for each endpoint), and a single receive queue. Each endpoint can have up to five transmit packets queued. The receive queue can accept 16 packets of any size combination before forcing the host to back off.

The arbiter makes the single-ported buffer RAM appear to be simultaneously available to the MCU, the four channels of the ISADMA, and the SIEDMA for receiving and transmitting packets.

ISADMA

This is an industry standard 8237 DMA controller to transfer data between the ISA bus and the SRAM under MMU control. This DMA contains status and control registers which can be accessed and programmed by the 8051 controller. The 8237 can run at 2, 4, or 8 MHz internally, or via an external clock to synchronize it with another source.

Applications

The USB97C100 enables entirely new I/O applications, as well as new form factors for existing Legacy I/O applications. PC98 compliance encourages the elimination of DMA, IRQ and addressing conflicts via total on-board ISA elimination. With the USB97C100, the ISA bus can be eliminated from motherboards without sacrificing the huge infrastructure of Legacy I/O ports. By moving these devices to the flexible USB bus, new form factors such as monitor peripheral clusters are also possible (mouse, keyboard, serial, parallel ports in a USB connected monitor). PC system designers are no longer constrained by the physical borders of the motherboard. The USB97C100 is ideal for USB peripherals which require considerable bandwidth, such as floppy drives, audio, IR, etc. The following block diagrams illustrate these applications.

TYPICAL PC MOTHERBOARD APPLICATION

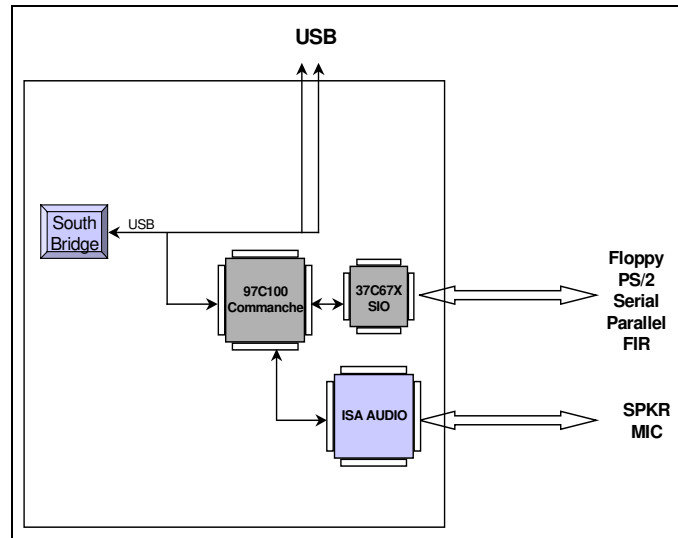

TYPICAL MONITOR APPLICATION

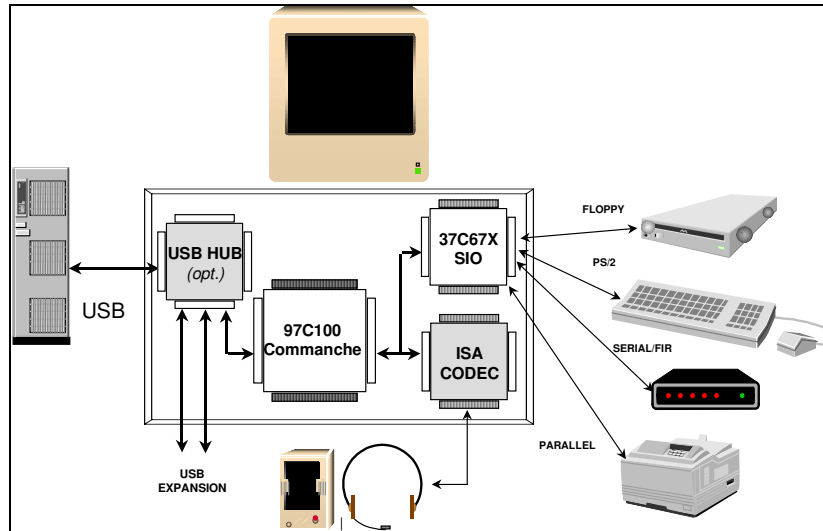

TYPICAL FLOPPY DRIVE APPLICATION

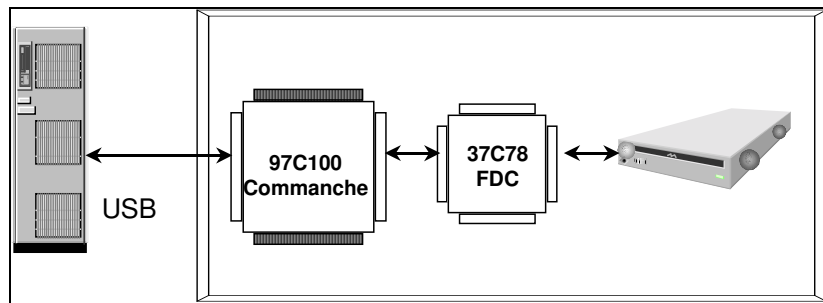

TYPICAL SIGNAL CONNECTIONS

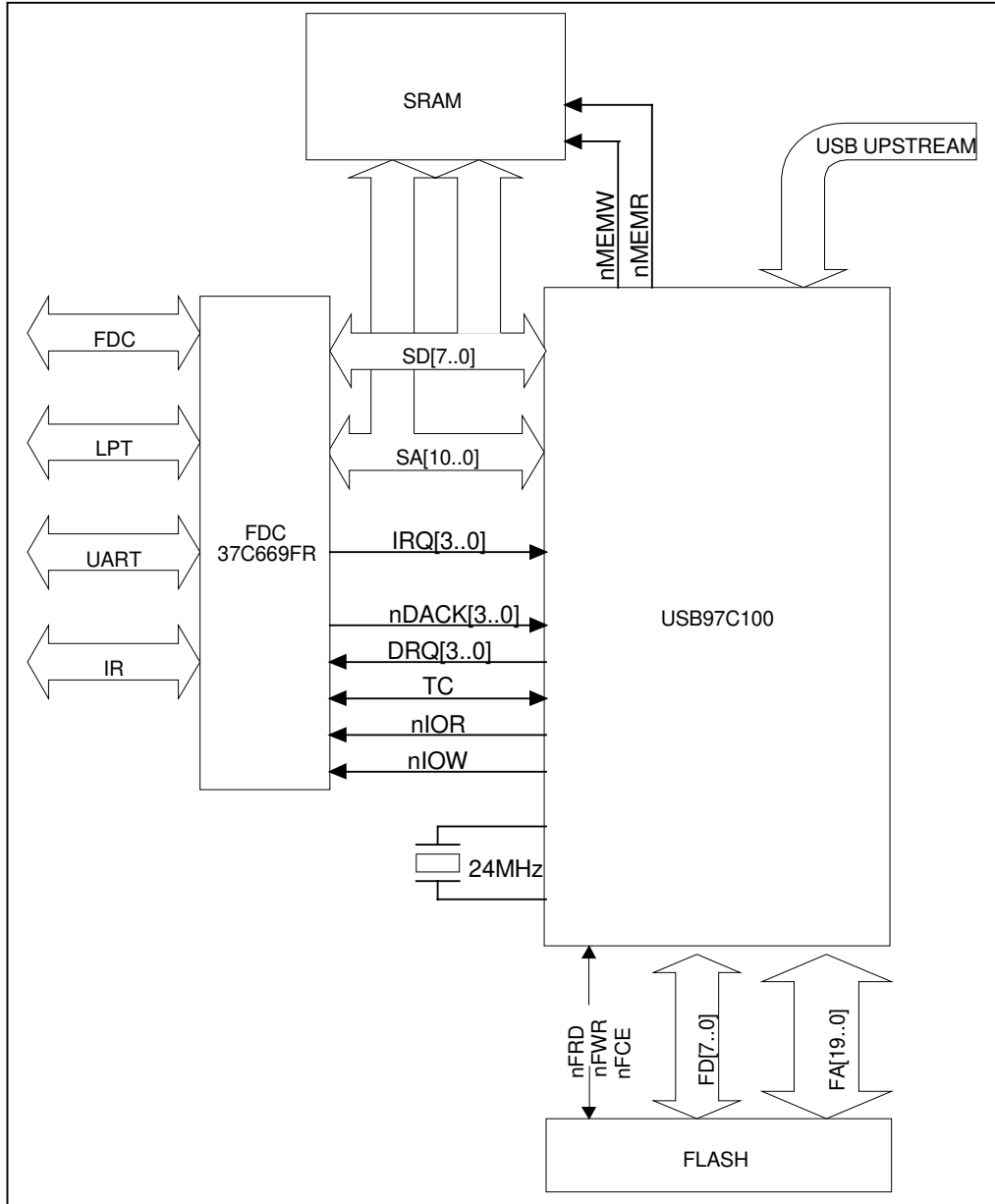

MCU Memory Map

The 64K memory map is as follows from the 8051's viewpoint:

Code Space

Table 3 - MCU Code Memory Map

8051 ADDRESS	CODE SPACE	ACCESS
0xC000-0xFFFF	Movable 16k page	External FLASH
0x8000-0xBFFF	Fixed 16k page	External FLASH
0x7000-0x7FFF	Movable 16k FLASH page 1 of 64 16k pages in	External FLASH
0x6000-0x6FFF	External FLASH (0x00000-0xFFFFF) selected by	External FLASH
0x5000-0x5FFF	MEM_BANK Register Default: 0x04000-	External FLASH
0x4000-0x4FFF	0x07FFFFFLASH	External FLASH
0x3000-0x3FFF	Fixed 16k FLASH Page	External FLASH
0x2000-0x2FFF	0x00000-0x03FFF FLASH	External FLASH
0x1000-0x1FFF		External FLASH
0x0000-0x0FFF		External FLASH

Data Space

Table 4 - MCU Data Memory Map

8051 ADDRESS	DATA SPACE	ACCESS
0xC000-0xFFFF	Movable 16k page Default : 0x04000-0x07FFF FLASH	External FLASH
0x8000-0xBFFF	Fixed 16k page 0x00000-0x03FFF FLASH	External FLASH
0x7000-0x7FFF	0x7F80-0x7F9F SIE Reg 0x7F70-0x7F7F ISA Reg 0x7F50-0x7F6F MMU Reg 0x7F20-0x7F2F Power Reg 0x7F10-0x7F1F Configuration Reg 0x7F00-0x7F0F Runtime Reg Note 1.	Internal
0x6000-0x6FFF	0x6000 MMU Data Register	Internal
0x5000-0x5FFF	0x5000-0x5FFF ISA MEMORY Window	ISA
0x4000-0x4FFF	0x4000-0x40FF ISA I/O Window	ISA
0x3000-0x3FFF		Not used
0x2000-0x2FFF		Not used
0x1000-0x1FFF		Not used
0x0000-0x00FF	Registers and SFR's	Internal

Note 1: The MCU, MMU, and SIE block registers are external to the 8051, but internal to the USB97C100. These addresses will appear on the FLASH bus, but the read and write strobes will be inhibited.

ISADMA Memory Map

The Internal Memory buffer is virtualized into the 8237's 64K address map as 32 independent 1k blocks. After the MMU has allocated a given packet size for a specific PNR, the MMU will make that packet appear to the 8237 as a contiguous block of data in the address ranges depicted in table 5.

Table 5 - ISADMA Memory Map

8237 MEMORY ADDRESS	DESCRIPTION
0x8000-0xFFFF	32 blocks of 1k Window to Packet
0x0000-0x7FFF	32K Window to External ISA RAM

MCU Block Register Summary

Table 6 - MCU Block Register Summary

ADDRESS	NAME	R/W	DESCRIPTION
RUNTIME REGISTERS			
7F00	ISR_0	R	INT0 Source Register
7F01	IMR_0	R/W	INT0 Mask Register
7F02	ISR_1	R	INT1 Source Register
7F03	IMR_1	R/W	INT1 Mask Register
7F06	DEV_REV	R	Device Revision Register
7F07	DEV_ID	R	Device ID Register
UTILITY REGISTERS			
7F18	GPIOA_DIR	R/W	GPIO Configuration Register
7F19	GPIOA_OUT	R/W	GPIO Data Output Register
7F1A	GPIOA_IN	R	GPIO Data Input Register
7F1B	UTIL_CONFIG	R/W	Miscellaneous Configuration Register
POWER MANAGEMENT REGISTERS			
7F27	CLOCK_SEL	R/W	8051 and 8237 Clock Select Register
7F29	MEM_BANK	R/W	Flash Bank Select
7F2A	WU_SRC_1	R	Wakeup Source
7F2B	WU_MSK_1	R/W	Wakeup Mask
7F2C	WU_SRC_2	R	Wakeup Source
7F2D	WU_MSK_2	R/W	Wakeup Mask
ISA BUS CONTROL REGISTERS			
7F10	GP1Data	R/W	GP FIFO Data Port #1
7F11	GP1Status	R	GP FIFO status Port #1
7F12	GP2Data	R/W	GP FIFO Data Port #2
7F13	GP2Status	R	GP FIFO status Port #2
7F14	GP3Data	R/W	GP FIFO Data Port #3
7F15	GP3Status	R	GP FIFO status Port #3
7F16	GP4Data	R/W	GP FIFO Data Port #4
7F17	GP4Status	R	GP FIFO status Port #4
7F70	BUS_REQ	R/W	ISA Bus Request Register
7F71	IOBASE	R/W	8051 ISA I/O Window Base Register
7F72	MEMBASE	R/W	8051 ISA Memory Window Base Register
7F73	BUS_STAT	R	ISADMA Request Status
7F74	BUS_MASK	R/W	ISADMA Request Interrupt Mask
7F7E	MCU_TEST2	N/A	Reserved for Test
7F7F	MCU_TEST1	N/A	Reserved for Test

MMU Block Register Summary

Table 7 - MMU Block Register Summary

ADDRESS	NAME	R/W	DESCRIPTION
MMU REGISTERS			
0x6000	MMU_DATA	R/W	8051-MMU Data Window Register FIFO
7F50	PRL	R/W	8051-MMU Pointer Register (Low)
7F51	PRH	R/W	8051-MMU Pointer Register (High) & R/W
7F52	MMUTX_SEL	R/W	8051-MMU TX FIFO Select for Commands
7F53	MMUCR	W	8051-MMU Command Register
7F54	ARR	R	8051-MMU Allocation Result Register
7F55	PNR	R/W	8051-MMU Packet Number Register
7F56	PAGS_FREE	R/W	Pages Free In the MMU
7F57	TX_MGMT	R	TX Management Register 2
7F58	RXFIFO	R	RX Packet FIFO Register (All EPs)
7F59	POP_TX	R	POP TX FIFO
7F60	TXSTAT_A	R	TX Packet FIFO Status Register (EP0-3)
7F61	TXSTAT_B	R	TX Packet FIFO Status Register (EP4-7)
7F62	TXSTAT_C	R	TX Packet FIFO Status Register (EP8-11)
7F63	TXSTAT_D	R	TX Packet FIFO Status Register (EP12-15)
7F64	MMU_TESTx	N/A	Reserved for Test
7F65	MMU_TESTx	N/A	Reserved for Test
7F66	MMU_TESTx	N/A	Reserved for Test
7F67	TX_MGMT	R/W	TX Management Register 1
7F6E	MMU_TESTx	N/A	Reserved for Test
7F6F	MMU_TESTx	N/A	Reserved for Test

SIE Block Register Summary

Table 8 - SIE Block Register Summary

ADDRESS	NAME	R/W	DESCRIPTION
SIE Control Registers			
7F80	EP_CTRL0	R/W	Endpoint 0 Control Register
7F81	EP_CTRL1	R/W	Endpoint 1 Control Register
7F82	EP_CTRL2	R/W	Endpoint 2 Control Register
7F83	EP_CTRL3	R/W	Endpoint 3 Control Register
7F84	EP_CTRL4	R/W	Endpoint 4 Control Register
7F85	EP_CTRL5	R/W	Endpoint 5 Control Register
7F86	EP_CTRL6	R/W	Endpoint 6 Control Register
7F87	EP_CTRL7	R/W	Endpoint 7 Control Register
7F88	EP_CTRL8	R/W	Endpoint 8 Control Register
7F89	EP_CTRL9	R/W	Endpoint 9 Control Register
7F8A	EP_CTRL10	R/W	Endpoint 10 Control Register
7F8B	EP_CTRL11	R/W	Endpoint 11 Control Register
7F8C	EP_CTRL12	R/W	Endpoint 12 Control Register
7F8D	EP_CTRL13	R/W	Endpoint 13 Control Register
7F8E	EP_CTRL14	R/W	Endpoint 14 Control Register
7F8F	EP_CTRL15	R/W	Endpoint 15 Control Register
7F90	FRAMEL	R	USB Frame Count Low
7F91	FRAMEH	R	USB Frame Count High
7F92	SIE_ADDR	R/W	USB Local Address Register
7F93	SIE_STAT	R	SIE Status Register
7F94	SIE_CTRL	R/W	SIE Control Register
7F95	SIE_TST1	R/W	Reserved Test Register
7F96	SIE_TST2	R/W	Reserved Test Register
7F97	SIE_EP_TEST	R/W	Reserved Test Register
7F98	SIE_CONFIG	R/W	SIE Configuration Register
7F99	ALT_ADDR1	R/W	Secondary Local Address Register #1
7F9A	SIE_TST3	R/W	Reserved Test Register
7F9B	SIE_TST4	R/W	Reserved Test Register
7F9C	SIE_TST5	R/W	Reserved Test Register
7F9D	SIE_TST6	R/W	Reserved Test Register
7F9E	ALT_ADDR2	R/W	Secondary Local Address Register #2
7F9F	ALT_ADDR3	R/W	Secondary Local Address Register #3

MCU REGISTER DESCRIPTION

MCU Runtime Registers

Table 9 - Interrupt 0 Source Register

ISR_0 (0x7F00 - RESET=0x00)			INTERRUPT 0 SOURCE REGISTER
BIT	NAME	R/W	DESCRIPTION
7	IRQ3	R	External interrupt input. 0 = Inactive 1 = Active
6	IRQ2	R	External interrupt input. 0 = Inactive 1 = Active
5	IRQ1	R	External interrupt input. 0 = Inactive 1 = Active
4	IRQ0	R	External interrupt input. 0 = Inactive 1 = Active
3	RX_PKT	R	1 = A Packet Number (PNR) has been successfully queued on the RXFIFO.
2	TX_EMPTY	R	1 = Whenever an enabled TX Endpoint's FIFO becomes empty. This will occur when the last queued packet in one of the 16 TX queues is successfully transferred to the Host.
1	TX_PKT	R	1 = A Packet was successfully transmitted.
0	ISADMA	R	1 = When a selected 8237 channels in BUS_STAT/BUS_MASK register pair either reached Terminal Count or have a new DMA Request Pending.

These bits are automatically cleared each time this register is read. Therefore, each time this register is read all pending interrupts must be serviced before continuing normal operation.

Notes:

- TX_EMPTY is useful for warning of USB performance degradation. This interrupt indicates that the next time the Host polls the affected endpoint, it will receive a NAK for that endpoint, thus reducing effective overall bandwidth due to retries. Firmware must use TX_STAT A, B, and C to determine which endpoint queue is empty.
- When ISADMA causes an interrupt, the 8237 CH_STAT register should also be read and serviced when the bit causing the interrupt is to be rearmed. When ISR_0 is read and the ISADMA bit is cleared, any other low-to-high transitions in the BUS_STAT register bits that are not masked will still cause an interrupt.

Table 10 - Interrupt 0 Mask

IMR_0 (0x7F01- RESET=0xFF)			INTERRUPT 0 MASK REGISTER
BIT	NAME	R/W	DESCRIPTION
7	IRQ3	R/W	External interrupt input mask 0 = Enable Interrupt 1 = Mask Interrupt
6	IRQ2	R/W	External interrupt input mask 0 = Enable Interrupt 1 = Mask Interrupt
5	IRQ1	R/W	External interrupt input mask 0 = Enable Interrupt 1 = Mask Interrupt
4	IRQ0	R/W	External interrupt input mask 0 = Enable Interrupt 1 = Mask Interrupt
3	RX_PKT	R/W	Received Packet MMU Interrupt Mask 0 = Enable Interrupt 1 = Mask Interrupt
2	TX_EMPTY	R/W	Transmit Queue Empty MMU Interrupt 0 = Enable Interrupt 1 = Mask Interrupt
1	TX_PKT	R/W	Transmit Packet MMU Interrupt Mask 0 = Enable Interrupt 1 = Mask Interrupt
0	ISADMA	R/W	ISADMA Status Change Interrupt Mask 0 = Enable Interrupt 1 = Mask Interrupt

Table 11 - Interrupt 1 Source Register

ISR_1 (0x7F02- RESET=0x00)			INTERRUPT 1 SOURCE REGISTER
BIT	NAME	R/W	DESCRIPTION
[7:5]	Reserved		Reserved
4	EOT	R	1 = The SIE returned to Idle State. Marks the end of each transaction.
3	SOF	R	1 = When a Start of Frame token is correctly decoded. Generated by the write strobe to the Frame Count register.
2	ALLOC	R	1 = MCU Software Allocation Request complete interrupt. This interrupt is not generated for hardware (SIEDMA) allocation requests.
1	RX_OVRN	R	1 = A receive condition has occurred that will stop the current receive buffer to not be processed. The SIE automatically recovers from this condition after its cause has been alleviated (e.g. any partially allocated packets will be released. See Note 2).
0	PWR_MNG	R	1 = A wakeup or power management event in the WU_SRC_1 or WU_SRC_2 registers has gone active.

Notes:

- These bits are cleared each time this register is read.
- The RX_OVRN interrupt should be considered by firmware as a general Receive Overrun of the SIE, meaning that a packet destined for the RAM buffer could not be received and was not acknowledged back to the Host. The firmware should check to see if the RX Packet Number FIFO Register (RXFIFO) is full. If it is empty, then there may be too many transmit packets queued for the device to receive anything, or the last packet may have been corrupted on the wire. If it is not empty, then one or more receive packets must be dequeued before the device can continue to receive packets. In the normal course of operation, the MCU should respond to a RX_PKT interrupt as often as possible and let the buffering logic do its job.

Table 12 - Interrupt 1 Mask

IMR_1 (0x7F03- RESET=0xFF)			INTERRUPT 1 MASK REGISTER
BIT	NAME	R/W	DESCRIPTION
[7:5]	Reserved		Reserved
4	EOT	R/W	EOT interrupt mask 0 = Enable Interrupt 1 = Mask Interrupt
3	SOF	R/W	Start of Frame Interrupt Mask 0 = Enable Interrupt 1 = Mask Interrupt
2	ALLOC	R/W	MCU Software Allocation Complete Interrupt Mask 0 = Enable Interrupt 1 = Mask Interrupt
1	RX_OVRN	R/W	Receive Overrun Interrupt Mask 0 = Enable Interrupt 1 = Mask Interrupt
0	PWR_MNG	R/W	Power Management Wakeup Interrupt Mask 0 = Enable Interrupt 1 = Mask Interrupt

Table 13 - Device Revision Register

DEV_REV (0x7F06- RESET=0xFF)			DEVICE REVISION REGISTER
BIT	NAME	R/W	DESCRIPTION
[7:0]	Rev.	R	This register defines additional revision information used internally by SMSC. The value is silicon revision dependent.

Table 14 - Device Identification Register

DEV_ID (0x7F07- RESET=0x25)			DEVICE IDENTIFICATION REGISTER
BIT	NAME	R/W	DESCRIPTION
[7:0]	BCD '25' HEX 0x25	R	This register defines additional revision information used internally by SMSC

Table 15– 8051 GP FIFO1

GP_FIFO1 (0x7F10- RESET=0xFF)			8051 GP FIFO1
BIT	NAME	R/W	DESCRIPTION
[7:0]	GP_FIFO1	R/W	8 byte deep GP FIFO. This data FIFOs must not be read unless the associated status bit indicates that FIFO is not empty.

Table 16– 8051 GP FIFO2

GP_FIFO2 (0x7F12 - RESET=0xFF)			8051 GP FIFO2
BIT	NAME	R/W	DESCRIPTION
[7:0]	GP_FIFO2	R/W	8 byte deep GP FIFO. This data FIFOs must not be read unless the associated status bit indicates that FIFO is not empty.

Table 17– 8051 GP FIFO3

GP_FIFO3 (0x7F14 - RESET=0xFF)			8051 GP FIFO3
BIT	NAME	R/W	DESCRIPTION
[7:0]	GP_FIFO3	R/W	8 byte deep GP FIFO. This data FIFOs must not be read unless the associated status bit indicates that FIFO is not empty.

Table 18 – 8051 GP FIFO4

GP_FIFO4 (0x7F16 - RESET=0xXX)			8051 GP FIFO4
BIT	NAME	R/W	DESCRIPTION
[7:0]	GP_FIFO4	R/W	8 byte deep GP FIFO. This data FIFOs must not be read unless the associated status bit indicates that FIFO is not empty.

FIFO Status Registers

Table 19 – 8051 GP FIFO 1 STATUS

GPFIFO1_STS (0x7F11 – RESET=0x01)			8051 GP FIFO status
BIT	NAME	R/W	DESCRIPTION
[7:2]	Reserved	R	Reserved
1	GPFIFO1_FULL	R	GP FIFO 1 full status 0 = Not FULL 1 = FULL
0	GPFIFO1_EMPTY	R	GP FIFO 1 empty status 0 = Has one or more TX packet 1 = Empty

Table 20– 8051 GP FIFO 2 STATUS

GPFIFO2_STS (0x7F13 – RESET=0x01)			8051 GP FIFO 2 status
BIT	NAME	R/W	DESCRIPTION
[7:2]	Reserved	R	Reserved
1	GPFIFO2_FULL	R	GP FIFO 2 full status 0 = Not FULL 1 = FULL
0	GPFIFO2_EMPTY	R	GP FIFO 2 empty status 0 = Has one or more TX packet 1 = Empty

Table 21 – 8051 GP FIFO 3 STATUS

GPFIFO3_STS (0x7F15 – RESET=0x01)			8051 GP FIFO 3 status
BIT	NAME	R/W	DESCRIPTION
[7:2]	Reserved	R	Reserved
1	GPFIFO3_FULL	R	GP FIFO 3 full status 0 = Not FULL 1 = FULL
0	GPFIFO3_EMPTY	R	GP FIFO 3 empty status 0 = Has one or more TX packet 1 = Empty

Table 22 – 8051 GP FIFO 4 STATUS

GPFIFO4_STS (0x7F17 – RESET=0x01)			8051 GP FIFO status
BIT	NAME	R/W	DESCRIPTION
[7:2]	Reserved	R	Reserved
1	GPFIFO4_FULL	R	GP FIFO 4 full status 0 = Not FULL 1 = FULL
0	GPFIFO4_EMPTY	R	GP FIFO 4 empty status 0 = Has one or more TX packet 1 = Empty

Table 23 - GPIO Direction Register

GPIOA_DIR (0x7F18- RESET=0x00)			MCU UTILITY REGISTERS
BIT	NAME	R/W	DESCRIPTION
7	GPIO7	R/W	GPIO7 Direction 0 = In 1 = Out
6	GPIO6	R/W	GPIO6 Direction 0 = In 1 = Out
5	GPIO5	R/W	GPIO5 Direction 0 = In 1 = Out
4	GPIO4	R/W	GPIO4 Direction 0 = In 1 = Out
3	GPIO3/T1	R/W	GPIO3 Direction 0 = In 1 = Out
2	GPIO2/T0	R/W	GPIO2 Direction 0 = In 1 = Out
1	GPIO1/TXD	R/W	GPIO1 Direction 0 = In 1 = Out
0	GPIO0/RXD	R/W	GPIO0 Direction 0 = In 1 = Out

Note: The Timer inputs T[1:0] can be configured as outputs and left unconnected so that software can write to the bits to trigger the timer. Otherwise, the Timer inputs can be used to count external events or internal SOF receptions.

Table 24 - GPIO Output Register

GPIOA_OUT (0x7F19- RESET=0x00)			GPIO DATA OUTPUT REGISTER A
BIT	NAME	R/W	DESCRIPTION
7	GPIO7	R/W	GPIO7 Output Buffer Data
6	GPIO6	R/W	GPIO6 Output Buffer Data
5	GPIO5	R/W	GPIO5 Output Buffer Data
4	GPIO4	R/W	GPIO4 Output Buffer Data
3	GPIO3/T1	R/W	GPIO3 Output Buffer Data
2	GPIO2/T0	R/W	GPIO2 Output Buffer Data
1	GPIO1/TXD	R/W	GPIO1 Output Buffer Data
0	GPIO0/RXD	R/W	GPIO0 Output Buffer Data

Table 25 - GPIO Input Register

GPIOA_IN (0x7F1A- RESET=0xXX)			GPIO INPUT REGISTER A
BIT	NAME	R/W	DESCRIPTION
7	GPIO7	R	GPIO7 Input Buffer Data
6	GPIO6	R	GPIO6 Input Buffer Data
5	GPIO5	R	GPIO5 Input Buffer Data
4	GPIO4	R	GPIO4 Input Buffer Data
3	GPIO3/T1	R	GPIO3 Input Buffer Data
2	GPIO2/T0	R	GPIO2 Input Buffer Data
1	GPIO1/TXD	R	GPIO1 Input Buffer Data
0	GPIO0/RXD	R	GPIO0 Input Buffer Data

Table 26 - Utility Configuration Register

UTIL_CONFIG (0x7F1B- RESET=0x00)			UTILITY CONFIGURATION REGISTER
BIT	NAME	R/W	DESCRIPTION
[7:4]	Reserved	R	Reserved
3	GPIO3/T1	R/W	P3.5 Timer 1 input trigger source 0 = GPIO3 1 = SOF FRAME write strobe
2	GPIO2/T0	R/W	P3.4 Timer 0 input trigger source 0 = GPIO2 1 = SOF FRAME write strobe
1	GPIO1/TXD	R/W	GPIO1/TXD Output Select Mux 0 = GPIO1 1 = P3.1
0	GPIO0/RXD	R/W	P3.0 RXD/GPIO0 Input Select Mux 0 = RXD<=GPIO0 1 = RXD<='0'

Notes:

- In Counter mode, the 8051 must sample T[1:0] as a '1' in one instruction cycle, and then '0' in the next. So for 12MHz, the SOF Pulse must be active for at least 1us.
- Missing SOF packets can be reconstructed by using the Timer mode to count the number of 8051 instruction cycles since the last valid Frame was received.
- A GPIO can be used to output nSOF pulses. This can be done by configuring a GPIO as an output and writing to the GPIO out register to generate low pulses each time a SOF packet is received.

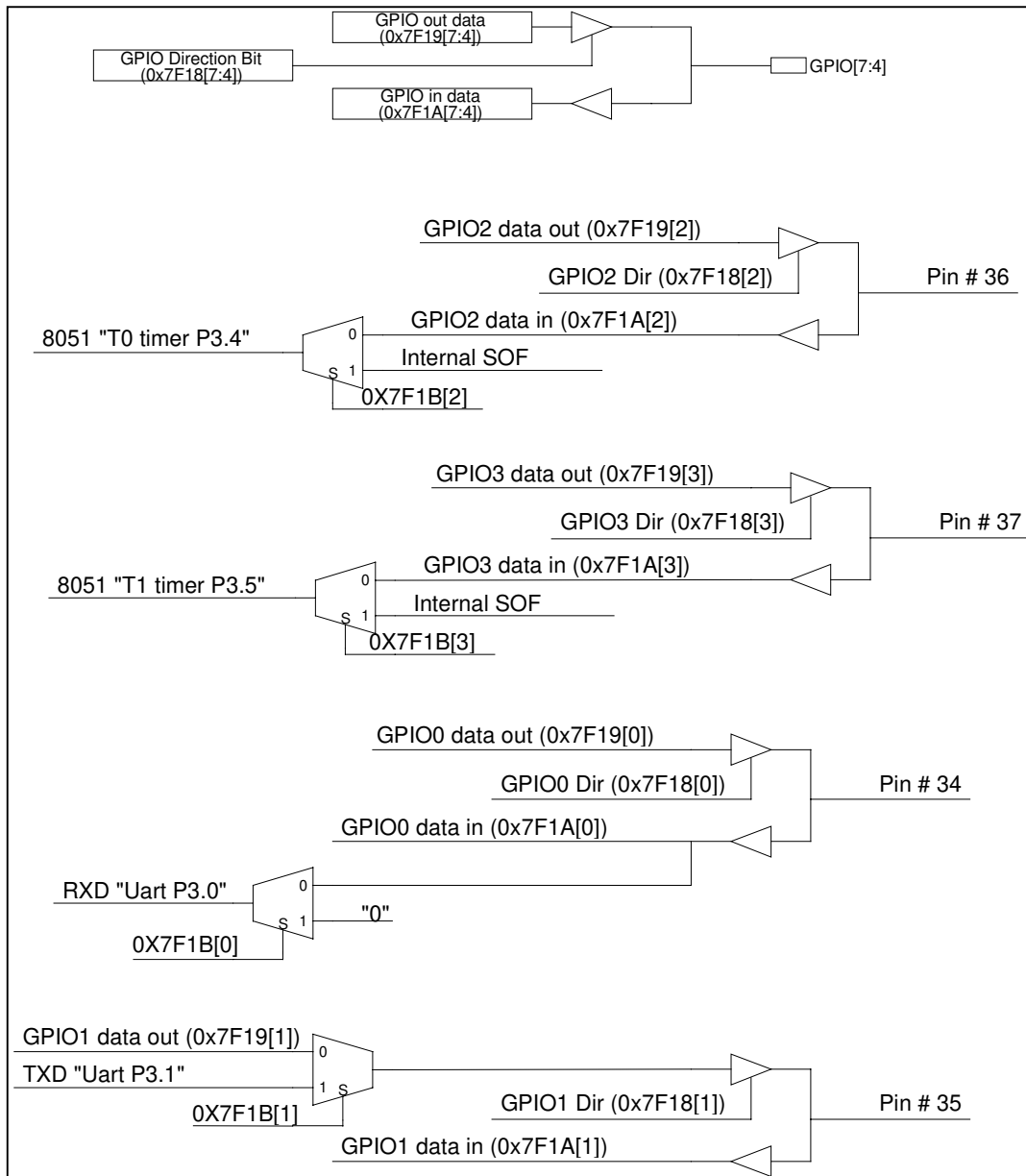

FIGURE 3 - GPIO MUXING BLOCK DIAGRAM

MCU Power Management Registers

Table 27 - MCU/ISADMA Clock Source Select

CLOCK_SEL (0x7F27 - RESET=0x40)			MCU/ISADMA CLOCK SOURCE SELECT
BIT	NAME	R/W	DESCRIPTION
7	SLEEP	R/W	When PCON. 0 = 1 and SLEEP has been set to 1, the ring oscillator will be gated off, then all oscillators will be turned off for maximum power savings. (These two signals can be used to generate nFCE)
6	ROSC_EN	R/W	0 = Ring Oscillator Disable. 1 = Ring Oscillator Enable. ROSC_EN must be set to 1 before the MCU can be switched to the internal Ring Oscillator Clock source.
5	MCUCLK_SRC	R/W	MCUCLK_SRC overrides MCUCLK_x clock select and switches the MCU to the Ring Oscillator. 0 = Use Ring Oscillator. ROSC_EN must be enabled by the MCU first. 1 = Use clock specified in MCU_CLK [1:0]
[4:3]	MCU_CLK[1:0]	R/W	[4:3] = 00: 8MHz [4:3] = 01: 12MHz [4:3] = 10: 16MHz [4:3] = 11: 24MHz
2	ISADMACLK_EXT	R/W	Selects an external clock source for the 8237 ISADMA controller for synchronizing the DMA with another block. NOTE: This will initially be an external input, but may eventually be used within the block to optimize performance, or as some other internal clock source. 0 = Use ISADMACLK[1..0] select 1 = Use EXT_IN clock source for 8237
[1:0]	ISADMACLK[1:0]	R/W	[1:0] = 00: Stopped [1:0] = 01: 2MHz [1:0] = 10: 4MHz [1:0] = 11: 8MHz

Notes:

- The 8051 may program itself to run off of an internal Ring Oscillator having a frequency range between 4 and 12MHz. This is not a precise clock, but is meant to provide the 8051 with a clock source, without running the 24MHz crystal oscillator or the PLL
- Switching between fast and slow clocks is recommended to save power.
- Clock switching can be done on the fly as long as both clocks are running. When switching, it takes a total of six clocks (3 clocks of the original clock plus 3 clocks of the switching clock) to guarantee the switching.
- Time TBD is required from ROSC_EN=1 to MCUCLK_SRC=0.

Table 28 - FLASH Bank Select Register

MEM_BANK (0x7F29 - RESET=0x01)			FLASH BANK SELECT REGISTER
BIT	NAME	R/W	DESCRIPTION
[7:6]	Reserved	R	Reserved
[5:0]	A[19:14]	R/W	This register selects which 16k page resides at 0x4000-0x7FFF in Code Space and 0xC000-0xFFFF in Data Space. The 0x0000-0x3FFF page will always reflect the 16K FLASH page 0 (0x00000-0x03FFF).

Table 29 - Wakeup Source 1 Register

WU_SRC_1 (0x7F2A - RESET=0x00)			WAKEUP SOURCE 1
BIT	NAME	R/W	DESCRIPTION
[7:3]	Reserved	R	Reserved
2	USB_Reset	R	This bit is set when the SIE detects simultaneous logic lows on D+ and D- (Single-Ended 0) for 32 to 64 full speed bit times, or 4 to 8 low speed bit times (or $2.5 < t < 5.5\mu s$). The USB_Reset signal may be as long as 10ms. SETUP tokens can be NAK'd for up to 10ms after the Reset signal is released.
1	Resume	R	This bit is set on detection of Global Resume state (when there is a transition from the "J" state while in Global Suspend).
0	Reserved '0'	R	Reserved

Notes:

- Only low to high transitions for the associated inputs sets these bits.
- These bits are cleared each time this register is read.
- Unmasked Wakeup Source bits generate an INT1 PWR_MNG interrupt, and restart the 8051 when its clock is stopped. This restarts the Ring Oscillator and crystal oscillator for the MCU to resume from $< 500\mu A$ operation.
- To initiate USB Remote Wakeup, the SIE_Resume bit should be used in the SIE_CONFIG register.

Table 30 - Wakeup Mask 1 Register

WU_MSK_1 (Note 1) (0x7F2B - RESET=0x07)			WAKEUP MASK 1
BIT	NAME	R/W	DESCRIPTION
[7:3]	Reserved	R	Reserved
2	USB_Reset	R/W	External wakeup event. 0 = Enabled 1 = Masked
1	Resume	R/W	External wakeup event. 0 = Enabled 1 = Masked
0	Reserved	R	Reserved

Note: Interrupt events enabled by these bits are routed to the PWR_MNG Bit 0 in the ISR_1 register.

Table 31 - Wakeup Source 2 Register

WU_SRC_2 (0x7F2C - RESET=0x00)			WAKEUP SOURCE 2
BIT	NAME	R/W	DESCRIPTION
[7:4]	'0'	R	Reserved
3	IRQ3	R	External Interrupt state since WU_SRC_2 was last read. 0 = Unchanged 1 = Changed
2	IRQ2	R	External Interrupt state since WU_SRC_2 was last read. 0 = Unchanged 1 = Changed
1	IRQ1	R	External Interrupt state since WU_SRC_2 was last read. 0 = Unchanged 1 = Changed
0	IRQ0	R	External Interrupt state since WU_SRC_2 was last read. 0 = Unchanged 1 = Changed

Notes:

- Any transition from high to low, or low to high on the associated input sets these bits. These bits are cleared each time this register is read.
- Since this register will report any status change, when devices are to be powered down while monitored, the appropriate bits must be masked until the device is armed correctly.

Table 32 - Wakeup Mask 2 Register

WU_MSK_2 (0x7F2D - RESET=0x0F)			WAKEUP MASK 2
BIT	NAME	R/W	DESCRIPTION
[7:4]	'0'	R	Reserved
3	IRQ3	R/W	External wakeup event enable. 0 = Enabled 1 = Masked
2	IRQ2	R/W	External wakeup event enable. 0 = Enabled 1 = Masked
1	IRQ1	R/W	External wakeup event enable. 0 = Enabled 1 = Masked
0	IRQ0	R/W	External wakeup event enable. 0 = Enabled 1 = Masked

Note: Interrupt events enabled by these bits are be routed to the PWR_MNG Bit 0 in the ISR_1 register.

MCU ISA Interface Registers

Table 33 – ISA Bus Request Register

BUS_REQ (0x7F70 – RESET=0x00)			ISA BUS REQUEST REGISTER
BIT	NAME	R/W	DESCRIPTION
7	INH_TC3	R/W	This bit inhibits DMA channel 3 TC.**See Note Below 0 = TC is driven onto the ISA bus via EOP as before. 1 = TC is forced inactive.
6	INH_TC2	R/W	This bit inhibits DMA channel 2 TC.** See Note Below 0 = TC is driven onto the ISA bus via EOP as before. 1 = TC is forced inactive.
5	INH_TC1	R/W	This bit inhibits DMA channel 1 TC.** See Note Below 0 = TC is driven onto the ISA bus via EOP as before. 1 = TC is forced inactive.
4	INH_TC0	R/W	This bit inhibits DMA channel 0 TC.** See Note Below 0 = TC is driven onto the ISA bus via EOP as before. 1 = TC is forced inactive.
3	RESET_8237	R/W	Writing a '1' holds the 8237 hardware reset input active. Writing '0' releases it for normal operation. May be used for clock switching or power management functions.
2	AEN	R	This bit reflects the status of the 8237's AEN pin. This bit does not generate an interrupt
1	HLDA	R/W	The 8051 can grant the bus when it is ready via HLDA. This should tri-state any common signals between the 8051 and the 8237 on the ISA bus.
0	HREQ	R	This bit reflects the status of the 8237's HREQ bus request pin. This bit does not generate an interrupt.

Note: HLDA Example: When the 8051 is running at 24MHz, and the 8237 is running at 2MHz, the 8237 may take up to 1.5us to complete a transfer after deasserting HLDA . When running the 8051 at 24MHz, wait states must be added when the 8237 is running at 2 or 4 MHz. When running the 8051 at 12MHz, wait states must be added when the 8237 is running at 2 MHz.

Note:** The “Inhibit” function is not valid for Memory-to-Memory DMA cycles

Table 34 - ISA Bus Status Register

BUS_STAT (0x7F73 - RESET=0xXX)			ISA BUS STATUS REGISTER
BIT	NAME	R/W	DESCRIPTION
7	CH3RQ	R	Channel 3 DMA Request 0 = No Request Pending 1 = Request Pending
6	CH2RQ	R	Channel 2 DMA Request 0 = No Request Pending 1 = Request Pending
5	CH1RQ	R	Channel 1 DMA Request 0 = No Request Pending 1 = Request Pending
4	CH0RQ	R	Channel 0 DMA Request 0 = No Request Pending 1 = Request Pending
3	CH3TC	R	Channel 3 Terminal Count Reached 0 = No 1 = Yes
2	CH2TC	R	Channel 2 Terminal Count Reached 0 = No 1 = Yes
1	CH1TC	R	Channel 1 Terminal Count Reached 0 = No 1 = Yes
0	CH0TC	R	Channel 0 Terminal Count Reached 0 = No 1 = Yes

Notes:

- Each bit in this register reflects the current value of the corresponding bit in the 8237 CH_STAT status register.
- The 8237 clears bits 3..0 in the CH_STAT status register when the 8051 reads it through the ISA Bus I/O Window.
- Reading the BUS_STAT register does not clear or otherwise affect the BUS_STAT register.
- The ISADMA bit in ISR_0 is latched high whenever any bit in BUS_STAT that is enabled in BUS_MASK transitions from low to high.
- This register is intended (1) to provide a view into the status of the 8237 without having to assume control of the ISA bus during DMA transfers, and (2) to provide a means for generating the ISADMA interrupt in ISR_0 which indicates that a DMA transfer has completed and that the 8051 should take control of the bus and setup the 8237 for its next transfer. Bits 7-4 can be used to generate additional interrupt requests from the DREQ pins, or simply to monitor channel request status by masking them.

Table 35 - ISA Bus Status Mask Register

BUS_MASK (0x7F74 - RESET=0xFF)			ISA BUS STATUS MASK REGISTER
BIT	NAME	R/W	DESCRIPTION
7	CH3RQ_MASK	R/W	Channel 3 DMA Request ISADMA Interrupt Mask 0 = Enable Interrupt 1 = Mask Interrupt
6	CH2RQ_MASK	R/W	Channel 2 DMA Request ISADMA Interrupt Mask 0 = Enable Interrupt 1 = Mask Interrupt
5	CH1RQ_MASK	R/W	Channel 1 DMA Request ISADMA Interrupt Mask 0 = Enable Interrupt 1 = Mask Interrupt
4	CH0RQ_MASK	R/W	Channel 0 DMA Request ISADMA Interrupt Mask 0 = Enable Interrupt 1 = Mask Interrupt
3	CH3TC_MASK	R/W	Channel 3 Terminal Count ISADMA Interrupt Mask 0 = Enable Interrupt 1 = Mask Interrupt
2	CH2TC_MASK	R/W	Channel 2 Terminal Count ISADMA Interrupt Mask 0 = Enable Interrupt 1 = Mask Interrupt
1	CH1TC_MASK	R/W	Channel 1 Terminal Count ISADMA Interrupt Mask 0 = Enable Interrupt 1 = Mask Interrupt
0	CH0TC_MASK	R/W	Channel 0 Terminal Count ISADMA Interrupt Mask 0 = Enable Interrupt 1 = Mask Interrupt

Table 36 - ISA I/O Window Base Register

IOBASE (0x7F71 - RESET=0x00)			ISA I/O WINDOW BASE REGISTER
BIT	NAME	R/W	DESCRIPTION
[7:0]	SA[15:8]	R/W	When the 8051 reads or writes to the ISA I/O Window, this register is combined with the 8 bit offset in the 256 byte window and presented as the 64k I/O Space address during an 8051-ISA IOR or IOW cycle

Table 37 - ISA Memory Window Base Register

MEMBASE (0x7F72 - RESET=0x00)			ISA MEMORY WINDOW BASE REGISTER
BIT	NAME	R/W	DESCRIPTION
[7:0]	SA[19:12]	R/W	When the 8051 reads or writes to the ISA Memory Window, this register is combined with the 12 bit offset in the 4k byte window and presented as the 1Mbyte Memory address during an 8051-ISA MEMR or MEMW cycle.

8237 (ISADMA) REGISTER DESCRIPTION

Memory Map

Table 38 - ISADMA Memory Map

8237 MEMORY ADDRESS	DESCRIPTION
0xFC00-0xFFFF	1k Window to Packet with PNR=0x1F
0xF800-0xFBFF	1k Window to Packet with PNR=0x1E
0xF400-0xF7FF	1k Window to Packet with PNR=0x1D
0xF000-0xF3FF	1k Window to Packet with PNR=0x1C
0xEC00-0xEFFF	1k Window to Packet with PNR=0x1B
0xE800-0xEBFF	1k Window to Packet with PNR=0x1A
0xE400-0xE7FF	1k Window to Packet with PNR=0x19
0xE000-0xE3FF	1k Window to Packet with PNR=0x18
0xDC00-0xDFFF	1k Window to Packet with PNR=0x17
0xD800-0xDBFF	1k Window to Packet with PNR=0x16
0xD400-0xD7FF	1k Window to Packet with PNR=0x15
0xD000-0xD3FF	1k Window to Packet with PNR=0x14
0xCC00-0xCFFF	1k Window to Packet with PNR=0x13
0xC800-0xCBFF	1k Window to Packet with PNR=0x12
0xC400-0xC7FF	1k Window to Packet with PNR=0x11
0xC000-0xC3FF	1k Window to Packet with PNR=0x10
0xBC00-0xBFFF	1k Window to Packet with PNR=0x0F
0xB800-0xBBFF	1k Window to Packet with PNR=0x0E
0xB400-0xB7FF	1k Window to Packet with PNR=0x0D
0xB000-0xB3FF	1k Window to Packet with PNR=0x0C
0xAC00-0xAFFF	1k Window to Packet with PNR=0x0B
0xA800-0xABFF	1k Window to Packet with PNR=0x0A
0xA400-0xA7FF	1k Window to Packet with PNR=0x09
0xA000-0xA3FF	1k Window to Packet with PNR=0x08
0x9C00-0x9FFF	1k Window to Packet with PNR=0x07
0x9800-0x9BFF	1k Window to Packet with PNR=0x06
0x9400-0x97FF	1k Window to Packet with PNR=0x05
0x9000-0x93FF	1k Window to Packet with PNR=0x04
0x8C00-0x8FFF	1k Window to Packet with PNR=0x03
0x8800-0x8BFF	1k Window to Packet with PNR=0x02
0x8400-0x87FF	1k Window to Packet with PNR=0x01
0x8000-0x83FF	1k Window to Packet with PNR=0x00
0x0000-0x7FFF	32K Window to External ISA RAM

The actual packet may be composed of up to 10 different 128 byte non-contiguous packets, but the MMU re-maps the internal addresses automatically such that the 8237 and 8051 only need to reference the packet number and offset within the packet. For example, suppose a 312 (0x138) byte packet is received by the SIEDMA from the host. The patented MMU allocates 384 bytes for the packet (including an 8 byte status header) and returns a PNR tag of 0x0A. The SIEDMA engine will place 0x0A in the receive packet queue and notify the 8051. The 8051 will take that PNR, examine the packet through its own PNR/Pointer registers, and determine the offset for the payload data it wants to transfer from the packet, say 0x027. The address it must calculate for the 8237 base address register would therefore be 0xA827 (0xA800+0x027). Each channel can be programmed with a different (or same) Packet Number and offset and the data will appear to it as ordinary contiguous RAM (see table 32 for more information).

Software written to this model will work for virtually any Endpoint number and Buffer size combination.

Runtime Registers

The DMA controller has a block of 16 R/W registers which normally occupy I/O locations 0x00-0x0F on the ISA bus. When they are located at 0x0000-0x000F on the ISA bus, the 8051 can access them by programming the IOBASE Register to 0x00, and reading or writing from 0x4000-0x400F.

Table 39 - 8237 Registers in ISA I/O Space

0x0000	Channel 0: Current Address H/L
0x0001	Channel 0: Byte Count H/L
0x0002	Channel 1: Current Address H/L
0x0003	Channel 1: Byte Count H/L
0x0004	Channel 2: Current Address H/L
0x0005	Channel 2: Byte Count H/L
0x0006	Channel 3: Current Address H/L
0x0007	Channel 3: Byte Count H/L
0x0008	Status/Command Register
0x0009	Write Request Register
0x000A	Write Single Mask Register
0x000B	Write Mode Register
0x000C	Clear Byte Ptr F/F - Read Temp Register
0x000D	Master Clear
0x000E	Clear Mask
0x000F	Write All Mask Bits

Note: To write to these registers, HLDA must be logic low.

Table 40 - 8237 Address Programming Guide

8237 INTERNAL ADDRESS PROGRAMMING GUIDE		
BIT	NAME	DESCRIPTION
15	INT_EXT	Indicates whether this address refers to Internal Buffer RAM or External ISA Memory Space 0 = External 1 = Internal When this bit is set to zero (0), I/O capability is added to External Memory DMA. This capability can only be used for DMA channels 2 or 3.
[14:10]	PN[4:0]/SA[14:10]	External Address -or- Internal Packet Number SA[14..10] when INT_EXT=0 PN[4..0] when INT_EXT=1
[9:0]	PTR[9:0]/SA[9:0]	External Address -or- Internal Packet Offset Pointer SA[9..0] when INT_EXT=0 PTR[9..0] when INT_EXT=1

Note: SA[19..15] are driven low when the 8237 is accessing external ISA memory. PTR10 is driven low when the 8237 is accessing internal buffer RAM. Note that the actual transfer size for the ISADMA is limited to 1024 bytes, which limits the payload data to 1016 bytes per transfer when the 8 byte header is skipped. Also note that the 8051 still has access to 1Meg of external RAM through the MEMBASE register and it is independent of the 8237's 32k external limit.

Table 41 - Channel 0 Current Address Register

CH0_ADDR (ISA 0x0000)			CHANNEL 0 CURRENT ADDRESS
BIT	NAME	R/W	DESCRIPTION
[7:0]	CH0_ADDRLL	R/W	Lower 8 bits of Base and Current Address when Byte F/F = 0
[7:0]	CH0_ADDRH	R/W	Upper 8 bits of Base and Current Address when Byte F/F = 1

Note: Byte F/F is an internal Flip Flop which reflects which byte (high or low) is being written. The CLEAR_FF register should be written to before writing this register to guarantee which byte (high or low) is being written. See the Address Programming Table for 16 bit Address definitions.

Table 42 - Channel 0 Byte Count Register

CH0_CNT (ISA 0x0001)			CHANNEL 0 BYTE COUNT
BIT	NAME	R/W	DESCRIPTION
[7:0]	CH0_CNTRL	R/W	Lower 8 bits of Byte Count when Byte F/F = 0
[7:0]	CH0_CNTH	R/W	Upper 8 bits of Byte Count when Byte F/F = 1

Note: The CLEAR_FF register should be written to before writing this register to guarantee which byte (high or low) is being written. See Address Programming Table for 16 bit Address definitions.

Table 43 - Channel 1 Current Address Register

CH1_ADDR (ISA 0x0002)			CHANNEL 1 CURRENT ADDRESS
BIT	NAME	R/W	DESCRIPTION
[7:0]	CH1_ADDRLL	R/W	Lower 8 bits of Base and Current Address when Byte F/F = 0
[7:0]	CH1_ADDRH	R/W	Upper 8 bits of Base and Current Address when Byte F/F = 1

Note: The CLEAR_FF register should be written to before writing this register to guarantee which byte (high or low) is being written. See the Address Programming Table for 16 bit Address definitions.

Table 44 - Channel 1 Byte Count Register

CH1_CNT (ISA 0x0003)			CHANNEL 1 BYTE COUNT
BIT	NAME	R/W	DESCRIPTION
[7:0]	CH1_CNTRL	R/W	Lower 8 bits of Byte Count when Byte F/F = 0
[7:0]	CH1_CNTH	R/W	Upper 8 bits of Byte Count when Byte F/F = 1

Note: The CLEAR_FF register should be written to before writing this register to guarantee which byte (high or low) is being written. See Address Programming Table for 16 bit Address definitions.

Table 45 - Channel 2 Current Address Register

CH2_ADDR (ISA 0x0004)			CHANNEL 2 CURRENT ADDRESS
BIT	NAME	R/W	DESCRIPTION
[7:0]	CH2_ADDRL	R/W	Lower 8 bits of Base and Current Address when Byte F/F = 0
[7:0]	CH2_ADDRH	R/W	Upper 8 bits of Base and Current Address when Byte F/F = 1

Note: The CLEAR_FF register should be written to before writing this register to guarantee which byte (high or low) is being written. See the Address Programming Table for 16 bit Address definitions.

Table 46 - Channel 2 Byte Count Register

CH2_CNT (ISA 0x0005)			CHANNEL 2 BYTE COUNT
BIT	NAME	R/W	DESCRIPTION
[7:0]	CH2_CNTRL	R/W	Lower 8 bits of Byte Count when Byte F/F = 0
[7:0]	CH2_CNTH	R/W	Upper 8 bits of Byte Count when Byte F/F = 1

Note: The CLEAR_FF register should be written to before writing this register to guarantee which byte (high or low) is being written. See Address Programming Table for 16 bit Address definitions.

Table 47 - Channel 3 Current Address Register

CH3_ADDR (ISA 0x0006)			CHANNEL 3 CURRENT ADDRESS
BIT	NAME	R/W	DESCRIPTION
[7:0]	CH3_ADDRL	R/W	Lower 8 bits of Base and Current Address when Byte F/F = 0
[7:0]	CH3_ADDRH	R/W	Upper 8 bits of Base and Current Address when Byte F/F = 1

Note: The CLEAR_FF register should be written to before writing this register to guarantee which byte (high or low) is being written. See the Address Programming Table for 16 bit Address definitions.

Table 48 - Channel 3 Byte Count Register

CH3_CNT (ISA 0x0007)			CHANNEL 3 BYTE COUNT
BIT	NAME	R/W	DESCRIPTION
[7:0]	CH3_CNTRL	R/W	Lower 8 bits of Byte Count when Byte F/F = 0
[7:0]	CH3_CNTH	R/W	Upper 8 bits of Byte Count when Byte F/F = 1

Note: The CLEAR_FF register should be written to before writing this register to guarantee which byte (high or low) is being written. See Address Programming Table for 16 bit Address definitions.

Table 49 - Channel Status Register

CH_STAT (ISA 0x0008)			CHANNEL STATUS REGISTER
BIT	NAME	R/W	DESCRIPTION
7	CH3RQ	R	Channel 3 DMA Request 0 = No Request Pending 1 = Yes Request Pending
6	CH2RQ	R	Channel 2 DMA Request 0 = No Request Pending 1 = Yes Request Pending
5	CH1RQ	R	Channel 1 DMA Request 0 = No Request Pending 1 = Yes Request Pending
4	CH0RQ	R	Channel 0 DMA Request 0 = No Request Pending 1 = Yes Request Pending
3	CH3TC	R	Channel 3 Terminal Count Reached 0 = No 1 = Yes
2	CH2TC	R	Channel 2 Terminal Count Reached 0 = No 1 = Yes
1	CH1TC	R	Channel 1 Terminal Count Reached 0 = No 1 = Yes
0	CH0TC	R	Channel 0 Terminal Count Reached 0 = No 1 = Yes

Notes:

- These bits are also visible outside of I/O space in the BUS_STAT register.
- These bits are cleared when this register is read through the ISA I/O Window.

Table 50 - 8237 Command Register

CH_CMD (ISA 0x0008)			COMMAND REGISTER
BIT	NAME	R/W	DESCRIPTION
7	DACK_SENS	W	DACK Sense 0 = Active High 1 = Active Low
6	DREQ_SENS	W	DREQ Sense (1 = Active Low, 0 = Active High)
5	WRITE_TIME	W	Write Timing Select 0 = Late Timing 1 = Extended
4	PRIORITY	W	Priority 0 = Fixed 1 = Rotating
3	COMP_TIME	W	Timing 0 = Normal 1 = Compressed
2	CTRL_EN	W	Controller Enable 0 = Enable 1 = Disable
1	ADDR_HOLD	W	Channel 0 Address Hold 0 = Disable 1 = Hold Enable
0	MEM2MEM	W	Memory-to-Memory 0 = Disable 1 = Enable

Table 51 - 8237 Write Single Request Register

CH_REQ (ISA 0x0009)			WRITE REQUEST REGISTER
BIT	NAME	R/W	DESCRIPTION
[7:3]	Reserved	W	Reserved
2	SET_CLR	W	Force Internal DMA Request Bit 0 = Clear 1 = Set
[1:0]	SEL[1:0]	W	'00' = Select Channel 0 DREQ '01' = Select Channel 1 DREQ '10' = Select Channel 2 DREQ '11' = Select Channel 3 DREQ

Table 52 - 8237 Write Single Mask Register

CH_MASK (ISA 0x000A)			WRITE SINGLE MASK REGISTER
BIT	NAME	R/W	DESCRIPTION
[7:3]	Reserved	R	Reserved
2	SET_CLR	W	Set Channel Mask Bit 0 = Clear 1 = Set
[1:0]	SEL[1:0]	W	'00' = Select Channel 0 Mask Bit '01' = Select Channel 1 Mask Bit '10' = Select Channel 2 Mask Bit '11' = Select Channel 3 Mask Bit

Table 53 - Write Mode Register

DMA_MODE (ISA 0x000B)			WRITE MODE REGISTER
BIT	NAME	R/W	DESCRIPTION
[7:6]	MODE[1:0]	W	'00' = Demand Mode Select '01' = Single Mode Select '10' = Block Mode Select '11' = Cascade Mode Select
5	INC_DEC	W	Auto-increment/Decrement 0 = Increment 1 = Decrement
4	AUTO_INIT	W	Auto-initialization 0 = Disable 1 = Enable
[3:2]	R/WV[1:0]	W	'00' = Verify Transfer '01' = Write Transfer '10' = Read Transfer '11' = Illegal 'XX' if bits 6 and 7 = '11' Or if CH_CMD register bit 0 = 1 (memory-to-memory transfer)
[1:0]	SEL[1:0]	W	'00' = Select Channel 0 '01' = Select Channel 1 '10' = Select Channel 2 '11' = Select Channel 3

Table 54 - Clear Byte Pointer Flip Flop Register

CLEAR_FF (ISA 0x000C)			CLEAR BYTE POINTER FLIP FLOP
BIT	NAME	R/W	DESCRIPTION
[7:0]	BPFF	W	This register must be written to clear the high/low byte pointer flip flop prior to reading or writing new address or word count information to the 8237.

Table 55 - Read Temporary Register

RD_TEMP (ISA 0x000D)			READ TEMPORARY REGISTER
BIT	NAME	R/W	DESCRIPTION
[7:0]	TEMP_BYTE	R	This location holds the value of the last byte transferred in a memory-to-memory operation.

Table 56 - Master Clear Register

MSTR_CLR: (ISA 0x000D)			MASTER CLEAR REGISTER
BIT	NAME	R/W	DESCRIPTION
[7:0]	SW_RESET	W	Writing to this register has the same effect on the registers as a hardware reset. The 8237 will enter the idle state.

Table 57 - Clear Mask Register

CLR_MASK: (ISA 0x000E)			CLEAR MASK REGISTER
BIT	NAME	R/W	DESCRIPTION
[7:0]	CLR_ALL	W	Writing to this register clears the mask bits of all four channels and allows them to receive DMA requests.

Table 58 - Clear All Mask Bits Register

ALL_MASK (ISA 0x000F)			WRITE ALL MASK BITS REGISTER
BIT	NAME	R/W	DESCRIPTION
[7:4]	Reserved	W	Reserved
3	CH3_MASK	W	Channel 3 Mask Bit (1 = Set Mask, 0 = Clear Mask)
2	CH2_MASK	W	Channel 2 Mask Bit (1 = Set Mask, 0 = Clear Mask)
1	CH1_MASK	W	Channel 1 Mask Bit (1 = Set Mask, 0 = Clear Mask)
0	CH0_MASK	W	Channel 0 Mask Bit (1 = Set Mask, 0 = Clear Mask)

MEMORY MANAGEMENT UNIT (MMU) REGISTER DESCRIPTION

MMU Interface Registers

Table 59 - MMU Data Window Register

MMU_DATA (0x6000)			MMU DATA WINDOW REGISTER
BIT	NAME	R/W	DESCRIPTION
[7:0]	[D7:D0]	R/W	Data Packet Window. When RCV in the PRH register = '1', this is the byte pointed to by the packet number on the top of the RXFIFO, and the packet offset of PRH:PRL. When RCV in the PRH register = '0', this is the byte pointed to by the packet number in the PNR register, and the packet offset of PRH:PRL.

Notes:

- The Read FIFO may take at most 1.218µs after the PNH is written to present valid data.
- The Write FIFO may take at most 2.520µs after writing the last byte of data to the FIFO to finish writing that data to the buffer.
- The worst case sequential access times to the FIFOs while the 8237 is simultaneously arbitrating for the MMU, and a USB packet is currently being transferred, is 588ns.
 - (READ) Therefore, after changing the PRH register, the 8051 should wait at least 2 instruction cycles (at 12MHz) before reading from this register. After waiting, the 8051, in auto-increment mode (PRH bit 6=1), can read a byte every cycle (at up to 16MHz).
 - (WRITE) The data register mode can be switched to write at any time, and data can be written immediately on every instruction cycle. After writing data, the 8051 should wait at least 3 instruction cycles (at 12MHz) before changing the PNR or PRH :PRL registers for a Read . Again, after waiting 1.218µs, the 8051 can read a byte every instruction cycle.

Table 60 - Pointer Register (Low)

PRL (0x7F50)			POINTER REGISTER (LOW)
BIT	NAME	R/W	DESCRIPTION
[7:0]	A[7:0]	R/W	LSB of the (0-1277 Max) offset of the allocated Packet Pointed to by PNR. The byte(s) pointed to by this register can be read and written to by the MCU at 0x6000.

Notes:

- This register must be written before PRH.
- The value read from this register is not necessarily what was last written to it, but actually the last address used to access the buffer RAM.

Table 61 - Pointer Register (High)

PRH (0x7F51)			POINTER REGISTER (HIGH)
BIT	NAME	R/W	DESCRIPTION
7	RCV	R/W	0 = The packet at 0x6000 is the packet pointed to by the PNR register. 1 = The packet available at 0x6000 is the packet pointed to by the packet on the top of the RX Packet Number FIFO.
6	AUTO_INCR	R/W	0 = Auto-increment is disabled 1 = Causes the PRH:PRL register to be automatically incremented each time the 0x6000 data window is accessed.
5	READ	R/W	Data register direction. This bit is required for the MMU/Arbiter to provide a transparent interface to the buffer RAM for the MCU. When first set, the MMU immediately fills the read FIFO. The MCU must wait 2.5us (60 Arbiter clocks) after writing to the MMU_DATA register before changing this bit from '0' to '1'. 0 = WRITE 1 = READ
[4:3]	Reserved	R	Reserved
[2:0]	A[10:8]	R/W	MSB of the (0-1277 Max) offset of the allocated Packet Pointed to by PNR. The byte(s) pointed to by this register can be read and written to by the MCU at 0x6000.

Note: This register must be written after PRL for its value to take effect.

Table 62 - Transmit FIFO Select Register

MMUTX_SEL (0x7F52)			TRANSMIT FIFO SELECT REGISTER
BIT	NAME	R/W	DESCRIPTION
[7:4]	Reserved	R	Reserved
[3:0]	EP[3:0]	R/W	This register selects which Endpoint Commands "110" and "111" will affect when issued to the MMU

Note: This register must be written before writing the "Enqueue Packet into Endpoint x" or the "Reset TX Endpoint x" command to the MMUCR .

Table 63 - MMU Command Register

MMUCR (0x7F53)			MMU COMMAND REGISTER
BIT	NAME	R/W	DESCRIPTION
[7:5]	MMU_CMD	W	MMUCR COMMAND SET
4	Reserved	W	Reserved, writes are ignored and read return "0"
[3:0]	N[3:0]	W	Number of 128 byte Pages. N[3..0]=0000 indicates 1 page, and N[3..0]=1001 indicates 10 pages, or 1280 bytes.

MMU COMMAND Bits 7, 6, and 5 Description:

000 NOOP, No operation

001 Allocate Memory : N3-0 specify how many 128 byte pages to allocate for that packet (up to 10 pages allowed (1280 bytes) per packet.) Immediately generates a "FAILED" code at the ARR and the code is cleared when complete. Can generate an ALLOC interrupt to MCU upon completion. When an allocation request cannot be completed due to insufficient memory, the FAILED bit in the ARR will remain set. Any subsequent release of memory pages (by either the MMUCR or the SIEDMA) will cause the MMUCR to automatically continue the allocate command until all requested pages have been successfully allocated. Software should never issue another allocate command until the previous allocate command has been successfully completed.

010 RESET MMU : Frees all buffer RAM, clears interrupts, and resets queue pointers.

- 011 Remove Packet from top of RX Queue : To be issued after MCU has completed processing the packet number at the RXFIFO.
- 100 Remove and Release Top of RXFIFO : Same as (011), but also frees all memory used by the packet. This command is especially useful as a quick way to "ignore" bad packets.
- 101 Release specific Packet : Frees all pages allocated to the packet specified in the PNR.
- 110 Enqueue Packet into Endpoint x : Places the Packet number indicated by the PNR register in the transmit queue of the endpoint pointed to by the MMUTX_SEL register. The MMUTX_SEL register must be written before this command is issued.
- 111 Reset TX Endpoint x : Resets the TX FIFO holding the packet numbers awaiting transmission and the TXFIFO_STAT bits of the endpoint pointed to by the MMUTX_SEL register. The MMUTX_SEL register must be written before this command is issued. This command does not release any memory allocated to packets that are dequeued.

Table 64 - Allocation Result Register

ARR (0x7F54)			ALLOCATION RESULT REGISTER
BIT	NAME	R/W	DESCRIPTION
7	FAILED	R	
[6:5]	Reserved	R	Reserved
[4:0]	P[4:0]	R	Returns Packet Number (0-31, 0x00-0x1F) from an allocation command. This can be written directly into the PNR register

Table 65 - Packet Number Register

PNR (0x7F55)			PACKET NUMBER REGISTER
BIT	NAME	R/W	DESCRIPTION
[7:5]	Reserved	R	Reserved
[4:0]	P[4:0]	R/W	Packet selector to access packet at 0x6000 buffer window

MMU Free Pages Register

MMU Free Pages bits, and a global NAK_ALLRX (this can only NACK OUT and Bulk packets) control bit for the firmware to view the real time status of the 32 page allocation bits. This allows the MCU to set NAK_ALLRX which would inhibit the SIE from asking the SIEDMA to allocate packets, MCU checks how many pages are left, issue an allocate if enough are free, and then release the SIE/SIEDMA. For the current design, the number of free pages would range from 0x00 to 0x1F (32) pages left unallocated.

The indication of pages free may be invalid during an allocation or deallocation.

Table 66 - Pages Free In The MMU

PAGS_FREE (0x7F56 - RESET=0x20)			PAGES FREE IN THE MMU
BIT	NAME	R/W	DESCRIPTION
7	NAK_ALLRX	R/W	NACK All received packets 0 = Normal Operation (Default) 1 = NACK all RX packets
6	Reserved	0	Reserved
[5:0]	PAGS_FREE	R	These bits indicate the number of free pages in the MMU.

Notes:

- Firmware can set a NAK_ALLRX bit to inhibit the SIE from asking the SIEDMA to allocate any pages while the MCU is observing the page free bits.
- This register is used to indicate how many pages are left in many situations, including after an RX_OVRN, before a multi-packet allocation, etc. This eliminates the possibility of a failed allocation, simplifying software without adding additional hardware to abort an allocation.

16 BYTE DEEP TX COMPLETION FIFO REGISTER

Table 67 - TX Management Register 2

TX_MGMT (0x7F57 - RESET=0x80)			TX Management Register
BIT	NAME	R/W	DESCRIPTION
7	CTX_EMPTY	R	Completed TX FIFO empty status 0 = Has one or more TX packet 1 = Empty
6	CTX_FULL	R	Completed TX FIFO full status 0 = Not FULL 1 = FULL
5	Reserved	R	Reserved
[4:0]	CTX_FIFO	R	This is the data port for the 16 deep TX completion FIFO. This FIFO is automatically updated by hardware with the last successfully completed transmit packet. It is the responsibility of software to ensure that this FIFO never overflows and/or becomes full.

Table 68 - Receive Packet Number FIFO Register

RXFIFO (0x7F58)			NEXT RX PACKET NUMBER FIFO REGISTER
BIT	NAME	R/W	DESCRIPTION
7	RXFIFO_EMPTY	R	1 = No pending packets from the host to be processed
6	RXFIFO_FULL	R	1 = The SIEDMA will not accept packets from the host (via RX Overflow)
5	Reserved	R	Reserved
[4:0]	P[4:0]	R	Packet Number When a packet has been received, and the 8-byte header has been written by the SIEDMA, the associated Packet Number is placed in this FIFO

A "complete" reception requires that the 8 byte status header is correctly written into the packet buffer, with the correct data, and moved into the RX Packet Number FIFO. A "successful" reception requires that the CRC and PID check bits of a "complete" reception are good. The hardware queues only "complete" packets. Firmware must determine if "complete" packets were "successful". Corrupted token packets causes the complete data payload to be ignored.

Tx FIFO POP Register

This register is used to help software manage TX Queues. This will provide a method to handle a CLEAR_FEATURE:ENDPOINT_STALL" condition gracefully. When read, this register will return the Packet Number of the next packet waiting on the TX queue pointed to by MMUTX_SEL register, AND it will pop that Packet Number off of the selected TX FIFO.

Table 69 - POP TX FIFO

POP_TX (0x7F59 – RESET=0x80)			POP TX FIFO
BIT	NAME	R/W	DESCRIPTION
7	POPTX_STAT	R	POP TX FIFO empty status 0 = Has one or more TX packet 1 = Empty
[6:5]	Reserved	R	Reserved
[4:0]	POP_TX	R	This 5 bit value is the packet number or handle that is at the top of the TX FIFO pointer to by MMUTX_SEL. The TX FIFO is popped when this register is read.

Note: It is the software's responsibility to ensure that the appropriate TX EP is disabled during this operation, and to issue a deallocate command if desired.

Table 70 - Transmit FIFO Status Register A

TXSTAT_A (0x7F60 - RESET=0x55)			TRANSMIT FIFO STATUS REGISTER A
BIT	NAME	R/W	DESCRIPTION
7	EP3TX_EMPTY	R	Endpoint 3 Transmit Packet FIFO Status Bits [7:6]='11' Invalid Bits [7:6]='10' Empty (No Packets queued) Bits [7:6]='01' Full (5 Packets queued) Bits [7:6]='00' Partially Full (1, 2, 3, or 4 Packets queued)
6	EP3TX_FULL	R	
5	EP2TX_EMPTY	R	Endpoint 2 Transmit Packet FIFO Status Bits [5:4]='11' Invalid Bits [5:4]='10' Empty (No Packets queued) Bits [5:4]='01' Full (5 Packets queued) Bits [5:4]='00' Partially Full (1, 2, 3, or 4 Packets queued)
4	EP2TX_FULL	R	
3	EP1TX_EMPTY	R	Endpoint 1 Transmit Packet FIFO Status Bits [3:2]='11' Invalid Bits [3:2]='10' Empty (No Packets queued) Bits [3:2]='01' Full (5 Packets queued) Bits [3:2]='00' Partially Full (1, 2, 3, or 4 Packets queued)
2	EP1TX_FULL	R	
1	EP0TX_EMPTY	R	Endpoint 0 Transmit Packet FIFO Status Bits [1:0]='11' Invalid Bits [1:0]='10' Empty (No Packets queued) Bits [1:0]='01' Full (5 Packets queued) Bits [1:0]='00' Partially Full (1, 2, 3, or 4 Packets queued)
0	EP0TX_FULL	R	

Table 71 - Transmit FIFO Status Register B

STAT_B (0x7F61 - RESET=0x55)			TRANSMIT FIFO STATUS REGISTER B
BIT	NAME	R/W	DESCRIPTION
7	EP7TX_EMPTY	R	Endpoint 7 Transmit Packet FIFO Status Bits [7:6]='11' Invalid Bits [7:6]='10' Empty (No Packets queued) Bits [7:6]='01' Full (5 Packets queued) Bits [7:6]='00' Partially Full (1, 2, 3, or 4 Packets queued)
6	EP7TX_FULL	R	
5	EP6TX_EMPTY	R	Endpoint 6 Transmit Packet FIFO Status Bits [5:4]='11' Invalid Bits [5:4]='10' Empty (No Packets queued) Bits [5:4]='01' Full (5 Packets queued) Bits [5:4]='00' Partially Full (1, 2, 3, or 4 Packets queued)
4	EP6TX_FULL	R	
3	EP5TX_EMPTY	R	Endpoint 5 Transmit Packet FIFO Status Bits [3:2]='11' Invalid Bits [3:2]='10' Empty (No Packets queued) Bits [3:2]='01' Full (5 Packets queued) Bits [3:2]='00' Partially Full (1, 2, 3, or 4 Packets queued)
2	EP5TX_FULL	R	

STAT_B (0x7F61 - RESET=0x55)			TRANSMIT FIFO STATUS REGISTER B
BIT	NAME	R/W	DESCRIPTION
1	EP4TX_EMPTY	R	Endpoint 4 Transmit Packet FIFO Status Bits [1:0]='11' Invalid Bits [1:0]='10' Empty (No Packets queued) Bits [1:0]='01' Full (5 Packets queued) Bits [1:0]='00' Partially Full (1, 2, 3, or 4 Packets queued)
0	EP4TX_FULL	R	

Table 72 - Transmit FIFO Status Register C

TXSTAT_C (0x7F62 - RESET=0x55)			TRANSMIT FIFO STATUS REGISTER C
BIT	NAME	R/W	DESCRIPTION
7	EP11TX_EMPTY	R	Endpoint 11 Transmit Packet FIFO Status Bits [7:6]='11' Invalid Bits [7:6]='10' Empty (No Packets queued) Bits [7:6]='01' Full (5 Packets queued) Bits [7:6]='00' Partially Full (1, 2, 3, or 4 Packets queued)
6	EP11TX_FULL	R	
5	EP10TX_EMPTY	R	Endpoint 10 Transmit Packet FIFO Status Bits [5:4]='11' Invalid Bits [5:4]='10' Empty (No Packets queued) Bits [5:4]='01' Full (5 Packets queued) Bits [5:4]='00' Partially Full (1, 2, 3, or 4 Packets queued)
4	EP10TX_FULL	R	
3	EP9TX_EMPTY	R	Endpoint 9 Transmit Packet FIFO Status Bits [3:2]='11' Invalid Bits [3:2]='10' Empty (No Packets queued) Bits [3:2]='01' Full (5 Packets queued) Bits [3:2]='00' Partially Full (1, 2, 3, or 4 Packets queued)
2	EP9TX_FULL	R	
1	EP8TX_EMPTY	R	Endpoint 8 Transmit Packet FIFO Status Bits [1:0]='11' Invalid Bits [1:0]='10' Empty (No Packets queued) Bits [1:0]='01' Full (5 Packets queued) Bits [1:0]='00' Partially Full (1, 2, 3, or 4 Packets queued)
0	EP8TX_FULL	R	

Table 73 - Transmit FIFO Status Register D

TXSTAT_D (0x7F63 - RESET=0x55)			TRANSMIT FIFO STATUS REGISTER D
BIT	NAME	R/W	DESCRIPTION
7	EP15TX_EMPTY	R	Endpoint 15 Transmit Packet FIFO Status Bits [7:6]='11' Invalid Bits [7:6]='10' Empty (No Packets queued) Bits [7:6]='01' Full (5 Packets queued) Bits [7:6]='00' Partially Full (1, 2, 3, or 4 Packets queued)
6	EP15TX_FULL	R	
5	EP14TX_EMPTY	R	Endpoint 14 Transmit Packet FIFO Status Bits [5:4]='11' Invalid Bits [5:4]='10' Empty (No Packets queued) Bits [5:4]='01' Full (5 Packets queued) Bits [5:4]='00' Partially Full (1, 2, 3, or 4 Packets queued)
4	EP14TX_FULL	R	
3	EP13TX_EMPTY	R	Endpoint 13 Transmit Packet FIFO Status Bits [3:2]='11' Invalid Bits [3:2]='10' Empty (No Packets queued) Bits [3:2]='01' Full (5 Packets queued) Bits [3:2]='00' Partially Full (1, 2, 3, or 4 Packets queued)
2	EP13TX_FULL	R	
1	EP12TX_EMPTY	R	Endpoint 12 Transmit Packet FIFO Status Bits [1:0]='11' Invalid Bits [1:0]='10' Empty (No Packets queued) Bits [1:0]='01' Full (5 Packets queued) Bits [1:0]='00' Partially Full (1, 2, 3, or 4 Packets queued)
0	EP12TX_FULL	R	

Table 74 - TX Management Register 1

TX_MGMT (0x7F67 - RESET=0x00)			TX Management Register 1
BIT	NAME	R/W	DESCRIPTION
[7:1]	Reserved	R	Reserved
0	MEM_DALL	R/W	Memory deallocate Mode 0 = Auto 1 = Manual deallocation, but the TX FIFO Pop is still automatic. This control bit selects between Auto and Manual memory pages deallocation. This bit should be statically set at the start of operation, and can not be changed during or if about to transmit. This bit defaults to "0" for normal operation. When set, the MCU handles freeing up the memory pages.

SERIAL INTERFACE ENGINE (SIE) REGISTER DESCRIPTION

Packet Header Definition

The following header contains information to determine endpoint, status, length of the received packet, and the payload "received data".

Table 75 - Packet Header Definition

OFFSET	MSB 7	6	5	4	3	2	1	LSB 0
<n + 7	Payload Data Byte n-1 (n is the payload data size, which is Byte Count -8) - For 0 Length Packet, Byte Count = 0x008 - For 1 byte Packet, Byte Count = 0x009 - For any Packet, (Byte Count-1) points to last byte of payload data							
0x008	Payload Data Byte 0							
0x007	0	0	0	0	0	BYTE COUNT[10..8]		
0x006	BYTE COUNT[7..0]							
0x005	EXTENDED FRAME COUNT[15..11]					FRAME COUNT[10..8]		
0x004	FRAME COUNT[7..0]							
0x003	RESERVED							
0x002	0	TMP_ADDRESS[6..0]						
0x001	0	0	0	0	PACKET ID[3..0]			
0x000	Bad_CRC	Last_TOG	Bad_TOG	0	ENDPOINT[3..0]			

Packet Description:

1. Offset 0 to 7 is the packet header.
 - a) Offset 0x000 to 0x005 is generated by the SIE.
 - i) Offset 0x000 bit 5 - Bad_TOG- This bit is set when the SIE receives an unexpected toggle. This is not necessarily an error condition, This bit could indicate a condition when the return handshake packet is lost .

Last Packet Toggle Value	Current Packet Toggle Value	"BAD TOG" bit
0	0	1
0	1	0
1	0	0
1	1	1

- ii) Offset 0x000 bit Last_TOG is the last toggle bit received.
 - iii) Offset 0x000 bit Bad_CRC, is set when the SIE detects a bad CRC.
 - b) Offset 0x006 to 0x007 is generated by the SIEDMA.
2. Offset 8 to n+7 is the actual data received from the USB bus and stored in memory.

SIE Interface Registers

The architecture of the USB97C100 is such that there are no data FIFO's associated with individual endpoints. The MMU does not differentiate packets by endpoint number. The firmware must read the endpoint number from the packet header to pass the packet on to the appropriate endpoint handler. This makes the chip dynamic and flexible in allocating buffers to store any payload size from 0 to 1280 bytes. Each endpoint can be configured separately via the following register:

Table 76 - Endpoint Control Registers

EP_CTRL[15..0] (0x7F8F-0x7F80 - RESET=0x00)			ENDPOINT CONTROL REGISTERS
BIT	NAME	R/W	DESCRIPTION
7	TX_ISO	R/W	<p>Bit 7 instructs the SIE how to handle handshakes for transmit endpoints during "IN" transactions, and how the SIEDMA engine should handle packet queue status after packet transmission. When a TX endpoint is configured for isochronous operation (Bit 7 = '1'), all packet transmissions are considered successful and the SIEDMA must move the packet number into the TX Completion FIFO. When the TX endpoint is non-isochronous (Bit 7 = '0'), then the SIE must receive a valid ACK handshake from the host before the packet is released. This guarantees data integrity for non-isochronous transactions. Successfully transmitted packets are automatically de-queued and the packet is released.</p> <p>0 = Non-Isochronous 1 = Isochronous</p>
6	RX_ISO	R/W	<p>Bit 6 instructs the SIE how to handle handshakes for receive endpoints during "OUT" and "SETUP" transactions. Once a packet matches the 7-bit Function Address, the SIE must begin page allocation and generate a new packet in buffer RAM. The MCU must check PID_Valid and CRC_Valid bits and dequeue "bad" packets. The SIE will use bit 6 to inhibit handshakes when enabled.</p> <p>0 = Non-isochronous 1 = Isochronous</p>
5,3	TX_CONT[1:0]	R/W	<p>0,0= Endpoint is disabled, and does not send handshakes. 0,1= Send a STALL handshake for an IN transaction directed at this EP. 1,0= Normal Operation. ACK or NAK is sent depending on whether data is in the EP's TX_QUEUE. 1,1= Send a NAK handshake for an IN transaction directed at this EP, regardless of TX_QUEUE status. (Note 3)</p>
4,2	RX_CONT[1:0]	R/W	<p>0,0= Endpoint is disabled, and does not send handshakes. 0,1= Send a STALL handshake for an OUT transaction directed at this EP. 1,0= Normal Operation. ACK or NAK is sent depending on RX_OK status 1,1= Send a NAK handshake for an OUT transaction directed at this EP (Note 1)</p>
1	TX_TOGGLE	R/W	<p>This bit is toggled after each successful transmission. TX_TOGGLE can be reset or cleared by the MCU but the MCU must insure that the endpoint is disabled before modifying them.</p>
0	RX_TOGGLE	R	<p>This bit reflects the last DATA0/DATA1 toggle.</p>

Notes:

- There is one Endpoint Control Register per virtual endpoint. When the SIE decodes a token, the endpoint number is used to index which EP_CTRL register bits should be used to respond to the SIE and SIEDMA.
- This register allows firmware to throttle back RX packets to any specific endpoint(s) until the firmware decides congestion has subsided.

- If the firmware needs to STALL an endpoint, it should first be taken off-line by setting RX_CONT1=0, and then RX_CON0=1.
- This allows firmware to manage TX endpoint(s) and hold queued data until the firmware is ready, even if the host is asking. This is not as critical as the RX version, but it may be required for Isochronous synchronization, as well as STALL recovery.

Table 77 - LSB FRAME Count Register

FRAMEL 0x7F90 Reset 0x00			FRAME COUNT REGISTER (LOW)
BIT	NAME	R/W	DESCRIPTION
[7:0]	FRAME[7:0]	R	The 11 bit Frame Number from each SOF packet is loaded with the RISING edge of EOT when SOF_TOKEN = '1' and ACK = '1'.

Note: This register is always the last correctly received valid SOF Frame number. Garbled and invalid SOF tokens do not alter this register.

Table 78 - MSB FRAME Count Register

FRAMEH 0x7F91 Reset 0x00			FRAME COUNT REGISTER (HIGH)
BIT	NAME	R/W	DESCRIPTION
[7:3]	EXT_FR[15:11]	R	Extended Frame Count. The extended count bits are loaded with the RISING edge of EOT when SOF_TOKEN = '1' and ACK = '1'. The extended Frame count bit must also be enabled (EN_EXTFRAME = '1' in SIE_CONFIG).
[2:0]	FRAME[10:8]	R	Frame Number from each SOF packet is loaded with the RISING edge of EOT when SOF_TOKEN = '1' and ACK = '1'.

Note: This register is always the last correctly received valid SOF Frame number. Garbled and invalid SOF tokens do not alter this register.

Table 79 - Local Address Register

SIE_ADDR (0x7F92 RESET=0x00)			LOCAL ADDRESS REGISTER
BIT	NAME	R/W	DESCRIPTION
7	RX_ALL	R/W	1 = Overrides the token address decoding of the SIE such that no compare is done. Token CRC is also ignored when RX_ALL=1. This bit forces all packets transmitted on the wire to be received in the RX Packet Queue
[6:0]	ADDR[6:0]	R/W	This register is only written by the 8051. It is the SIE's local address assigned during enumeration. This SIE address allows Endpoints 0 through 3 to be available. This address can be used for the HUB address.

Note: When RX_ALL is enabled, software should not enable any TX endpoints as they will respond to any Address with the same endpoint and possibly cause contention on the line. Software should also set each RX endpoint RX_ISO bit to prevent handshakes from being sent.

Table 80 - Alternate Address 1 Register

ALT_ADDR1 (0x7F99 - RESET=0x00)			ALTERNATE SIE ADDRESS 1
BIT	NAME	R/W	DESCRIPTION
7	EN_ALTADDR1	R/W	Alternate address. 1 = Enabled, this bit allows Endpoints 15 through 0 to be available as Endpoint ALT0 through Endpoint ALT15. In other words, the SIE can respond to two addresses with up to 32 endpoints distributed between them. 0 = Disabled, this register does not affect EP_OK generation.
6	ALT6	R/W	Alternate address bit 6
5	ALT5	R/W	Alternate address bit 5
4	ALT4	R/W	Alternate address bit 4
3	ALT3	R/W	Alternate address bit 3
2	ALT2	R/W	Alternate address bit 2
1	ALT1	R/W	Alternate address bit 1
0	ALT0	R/W	Alternate address bit 0

Notes:

- Endpoint numbers used for ALT_ADDRx are the compliment of the actual Endpoint number received. For example, any packets sent to Endpoint "0" of the ALT_ADDRx will appear as Endpoint 15.
- The Firmware (8051) must make sure that endpoint configurations do not overlap.

Table 81- Alternate Address 2 Register

ALT_ADDR2 (0x7F9E – RESET=0x00)			ALTERNATE SIE ADDRESS 2
BIT	NAME	R/W	DESCRIPTION
7	EN_ALTADDR2	R/W	Alternate address 2. 1 = Enabled, this bit allows Endpoints 8 through 11 to be available to this address. 0 = Disabled, this register does not affect EP_OK generation.
6	ALT6	R/W	Alternate address bit 6
5	ALT5	R/W	Alternate address bit 5
4	ALT4	R/W	Alternate address bit 4
3	ALT3	R/W	Alternate address bit 3
2	ALT2	R/W	Alternate address bit 2
1	ALT1	R/W	Alternate address bit 1
0	ALT0	R/W	Alternate address bit 0

Table 82 - Alternate Address 3 Register

ALT_ADDR3 (0x7F9F – RESET=0x00)			ALTERNATE SIE ADDRESS 3
BIT	NAME	R/W	DESCRIPTION
7	EN_ALTADDR 3	R/W	Alternate address 3. 1 = Enabled, this bit allows Endpoints 12through 15 to be available to this address. 0 = Disabled, this register does not affect EP_OK generation.
6	ALT6	R/W	Alternate address bit 6
5	ALT5	R/W	Alternate address bit 5
4	ALT4	R/W	Alternate address bit 4
3	ALT3	R/W	Alternate address bit 3
2	ALT2	R/W	Alternate address bit 2
1	ALT1	R/W	Alternate address bit 1
0	ALT0	R/W	Alternate address bit 0

Table 83 - SIE Status Register

SIE_STAT (0x7F93 - RESET=0xXX)			SIE STATUS REGISTER
BIT	NAME	R/W	DESCRIPTION
7	ERR	R	Indicates that an error occurred during the last USB transaction. Considered valid on the rising edge of EOT
6	TIMEOUT	R	Indicate that the last USB transaction ended because of an inter-packet time out condition (i.e.:>16 bit times). Considered valid on the rising edge of EOT.
5	SETUP_TOKEN	R	Indicates that the token received was a SETUP token.
4	SOF_TOKEN	R	Indicates that the SOF PID has been received. Considered valid when EOT is '0'.
3	PRE_TOKEN	R	Indicates that the SIE detected a PRE (preamble) packet on the USB bus. The signal is asserted when the SIE has seen a valid SYNC followed by a valid PRE PID.
2	ACK	R	Indicates that the last USB transaction was completed without error or time-out. Considered valid on the rising edge of EOT.
1	USB_RESET	R	When active '1', it indicates that the USB line is being reset. This signal is asserted when the SIE detects a string of single - ended 0's on the bus for a long time.
0	EOT	R	End - of - Transaction. On transition to a '1', it indicates the end of transaction. On transition to a '0' it indicates the beginning of a new transaction.

Note: This read only register reflects the status signals from the SIE state machine. This register can be polled for test purposes, or by error handling routines for recovery.

Table 84 - SIE Control Register

SIE_CTRL (0x7F94 - RESET=0x00)			SIE CONTROL REGISTER
BIT	NAME	R/W	DESCRIPTION
7	SIEDMA_DISABLE	R/W	0 = Normal operation 1 = Inhibits SIEDMA operation to facilitate MCU override
6	FORCE_RXOK	R/W	Forces SIE to send Acknowledge during receive. Must be '0' for normal operation.
5	FORCE_TTAG	R/W	0 = Normal operation. 1 = Signals that the next byte written to the SIE TX_FIFO is the last payload byte.
4	FORCE_RXOVFLO	R/W	0 = Normal operation. 1 = Forces the SIE to generate RXOVFLO and clear the SIE RX FIFO.
3	FORCE_TXABORT	R/W	0 = Normal operation 1 = Forces a bit-stuff error at the host
2	FORCE_EOT	R/W	0 = Normal operation. 1 = Forces an End-of-Transaction for the SIE
1	RTAG_IN	R	Status of RTAG signal from SIE RX FIFO
0	TXOK_IN	R	Status of TXOK from SIE

Note: Bits 7:2 must be set to "0" for normal operation. Altering these bits will cause an abnormal USB behavior.

Table 85 - SIE Configuration Register

SIE_CONFIG (0x7F98 - RESET=0x40)			SIE CONFIGURATION REGISTER
BIT	NAME	R/W	DESCRIPTION
7	FSEN	R/W	This bit indicates that the USB97C100 supports 12Mbps USB data rates. This bit must be set to a one '1' for normal operation.
6	RST_SIE	R/W	1 = Resets the SIE
5	RST_FRAME	R/W	1 = Clears FRAMEL and Bit 0 through 2 of FRAMEH
4	EN_EXTFRAME	R/W	Extended Frame Count Enable. Expands the Frame count from 11 bits to 16 bits for 8051 use. 0 = bits 7-3 of FRAMEH are driven to 0. 1 = Bits 7-3 of FRAMEH count 1-0 transitions of bit 2 in FRAMEH.
3	SIE_SUSPEND	R/W	1 = Forces the SIE into USB Suspend Mode. The MCU must determine that Suspend must be entered.
2	SIE_RESUME	R/W	1 = Forces the SIE to transmit Resume signaling on the line.
1	USB_RESUME	R	1 = Indicates Resume signaling has been detected on the line while in the Suspend State. This signal causes a Resume Power Management interrupt).
0	USB_RESET	R	1 = Indicates that the USB line is being reset. Asserted when SE0 is present on the bus for 32 or more 12Mbps bit times. This causes a USB_RESET Power management interrupt.

DC PARAMETERS

MAXIMUM GUARANTEED RATINGS

Operating Temperature Range	0°C to +70°C
Storage Temperature Range	-55° to +150°C
Lead Temperature Range (soldering, 10 seconds).....	+325°C
Positive Voltage on any pin, with respect to Ground	V _{CC} +0.3V
Negative Voltage on any pin, with respect to Ground	-0.3V
Maximum V _{CC}	+7V

*Stresses above the specified parameters could cause permanent damage to the device. This is a stress rating only and functional operation of the device at any other condition above those indicated in the operation sections of this specification is not implied.

Note: When powering this device from laboratory or system power supplies, it is important that the Absolute Maximum Ratings not be exceeded or device failure can result. Some power supplies exhibit voltage spikes on their outputs when the AC power is switched on or off. In addition, voltage transients on the AC power line may appear on the DC output. When this possibility exists, it is suggested that a clamp circuit be used.

DC ELECTRICAL CHARACTERISTICS (T_A = 0°C - 70°C, V_{CC} = +3.3 V ± 10%)

PARAMETER	SYMBOL	MIN	TYP	MAX	UNITS	COMMENTS
I Type Input Buffer						
Low Input Level	V _{ILI}			0.8	V	TTL Levels
High Input Level	V _{IHI}	2.0			V	
ICLK Input Buffer						
Low Input Level	V _{ILCK}			0.4	V	
High Input Level	V _{IHCK}	2.2			V	
Input Leakage (All I and IS buffers)						
Low Input Leakage	I _{IL}	-10		+10	µA	V _{IN} = 0
High Input Leakage	I _{IH}	-10		+10	µA	V _{IN} = V _{CC}
O8 Type Buffer						
Low Output Level	V _{OL}			0.4	V	I _{OL} = 8 mA @ V _{CC} = 5V I _{OL} = 4 mA @ V _{CC} = 3.3V
High Output Level	V _{OH}	2.4			V	I _{OH} = -4 mA @ V _{CC} = 5V I _{OH} = -2 mA @ V _{CC} = 3.3V
Output Leakage	I _{OL}	-10		+10	µA	V _{IN} = 0 to V _{CC} (Note 1)

PARAMETER	SYMBOL	MIN	TYP	MAX	UNITS	COMMENTS
I/O8 Type Buffer						
Low Output Level	V_{OL}			0.4	V	$I_{OL} = 8 \text{ mA} @ V_{CC} = 5\text{V}$ $I_{OL} = 4 \text{ mA} @ V_{CC} = 3.3\text{V}$
High Output Level	V_{OH}	2.4			V	$I_{OH} = -4 \text{ mA} @ V_{CC} = 5\text{V}$ $I_{OH} = -2 \text{ mA} @ V_{CC} = 3.3\text{V}$
Output Leakage	I_{OL}	-10		+10	μA	$V_{IN} = 0 \text{ to } V_{CC}$ (Note 1)
I/O16 Type Buffer						
Low Output Level	V_{OL}			0.4	V	$I_{OL} = 16 \text{ mA} @ V_{CC} = 5\text{V}$ $I_{OL} = 8 \text{ mA} @ V_{CC} = 3.3\text{V}$
High Output Level	V_{OH}	2.4			V	$I_{OH} = -8 \text{ mA} @ V_{CC} = 5\text{V}$ $I_{OH} = -4 \text{ mA} @ V_{CC} = 3.3\text{V}$
Output Leakage	I_{OL}	-10		+10	μA	$V_{IN} = 0 \text{ to } V_{CC}$ (Note 1)
I/O24 Type Buffer						
Low Output Level	V_{OL}			0.4	V	$I_{OL} = 24 \text{ mA} @ V_{CC} = 5\text{V}$ $I_{OL} = 12 \text{ mA} @ V_{CC} = 3.3\text{V}$
High Output Level	V_{OH}	2.4			V	$I_{OH} = -12 \text{ mA} @ V_{CC} = 5\text{V}$ $I_{OH} = -6 \text{ mA} @ V_{CC} = 3.3\text{V}$
Output Leakage	I_{OL}	-10		+10	μA	$V_{IN} = 0 \text{ to } V_{CC}$ (Note 1)
IO-U						
Note 2						
Supply Current Unconfigured <i>Note: MCU running on Ring Oscillator</i>	I_{CCINIT}		13 27	17 35	mA mA	@ $V_{CC} = 3.3\text{V}$ @ $V_{CC} = 5.0\text{V}$
Supply Current Active	I_{CC}		21 42	32 63	mA mA	@ $V_{CC} = 3.3\text{V}$ @ $V_{CC} = 5.0\text{V}$
Supply Current Standby	I_{CSBY}		14 130	60 350	μA μA	@ $V_{CC} = 3.3\text{V}$ @ $V_{CC} = 5.0\text{V}$

Note 1: Output leakage is measured with the current pins in high impedance.

Note 2: See Appendix A for USB DC electrical characteristics.

CAPACITANCE $T_A = 25^\circ\text{C}$; $f_c = 1\text{MHz}$; $V_{CC} = 3.3\text{V}$

PARAMETER	SYMBOL	LIMITS			UNIT	TEST CONDITION
		MIN	TYP	MAX		
Clock Input Capacitance	C_{IN}			20	pF	All pins except USB pins (and pins under test tied to AC ground)
Input Capacitance	C_{IN}			10	pF	
Output Capacitance	C_{OUT}			20	pF	

USB PARAMETERS

The following tables and diagrams were obtained from the USB specification

USB DC PARAMETERS

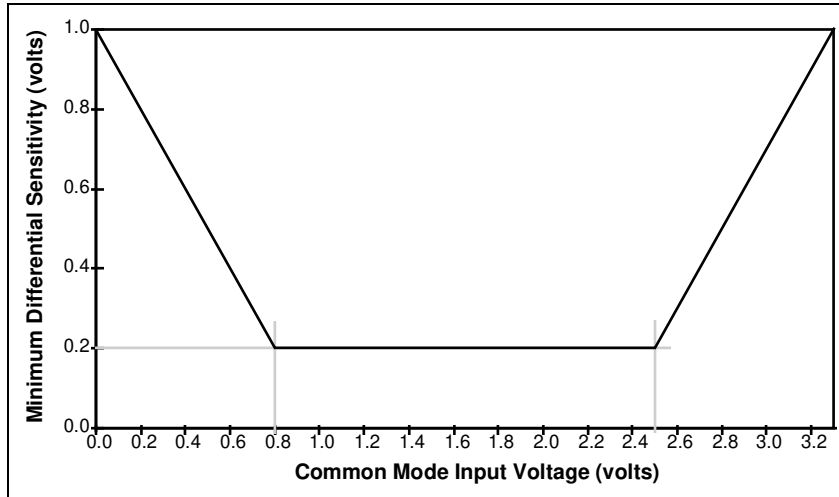

FIGURE 4 - DIFFERENTIAL INPUT SENSITIVITY OVER ENTIRE COMMON MODE RANGE

Table 86 - DC Electrical Characteristics

PARAMETER	SYMBOL	CONDITIONS (NOTE 1, 2)	MIN	TYP	MAX	UNIT
Supply Voltage:						
Powered (Host or Hub) Port	VBUS		2.97		3.63	V
Supply Current:						
Function	ICC	Note 4			100	mA
Un-configured Function (in)	ICCNIT	Note 5			100	uA
Suspend Device	ICCS				200	uA
Leakage Current:						
Hi-Z State Data Line Leakage	ILO	$0\text{ V} < V_{IN} < 3.3\text{ V}$	-10		10	uA
Input Levels:						
Differential Input Sensitivity	VDI	$ (D+) - (D-) $, and FIGURE 4	0.2			V
Differential Common Mode Range	VCM	Includes VDI range	0.8		2.5	V
Single Ended Receiver Threshold	VSE		0.8		2.0	V
Output Levels:						
Static Output Low	VOL	RL of 1.5 K Ω to 3.6 V			0.3 (3)	V
Static Output High	VOH	RL of 15 K Ω to GND	2.8		3.6 (3)	V

PARAMETER	SYMBOL	CONDITIONS (NOTE 1, 2)	MIN	TYP	MAX	UNIT
Capacitance						
Transceiver Capacitance	CIN	Pin to GND			20	pF
Terminals						
Bus Pull-up Resistor on Root Port	RPU	(1.5 K Ω +/- 5%)	1.425		1.575	k Ω
Bus Pull-down Resistor on Downstream Port	RPD	(15 K Ω +/- 5%)	14.25		15.75	k Ω

Note 1: All voltages are measured from the local ground potential, unless otherwise specified.

Note 2: All timing use a capacitive load (CL) to ground of 50pF, unless otherwise specified.

Note 3: This is relative to VUSBIN.

Note 4: This is dependent on block configuration set by software.

Note 5: When the internal ring oscillator and waiting for first setup packet.

USB AC PARAMETERS

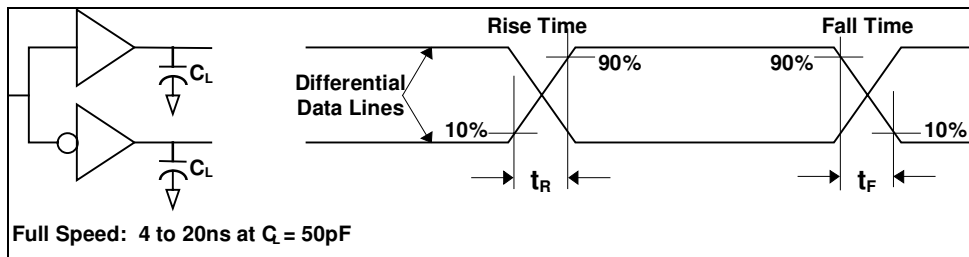

FIGURE 5 - DATA SIGNAL RISE AND FALL TIME

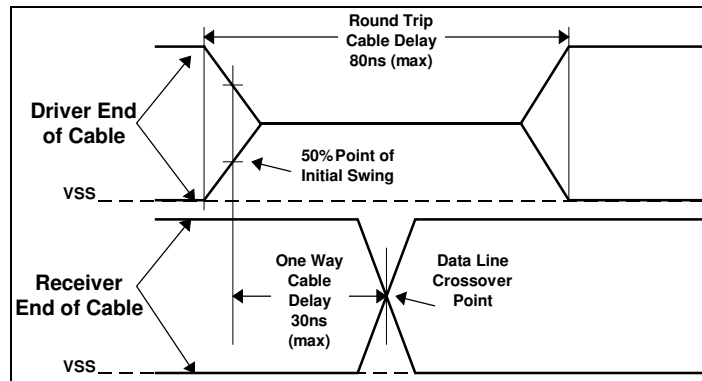

FIGURE 6 - CABLE DELAY

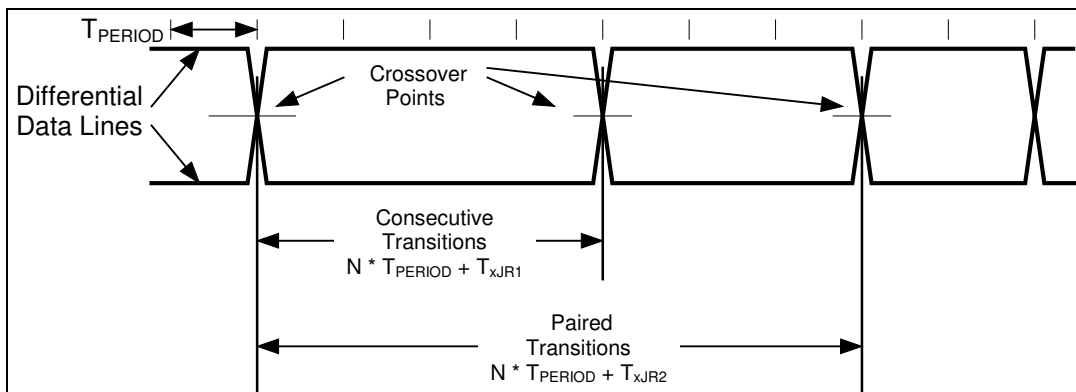

FIGURE 7 - DIFFERENTIAL DATA JITTER

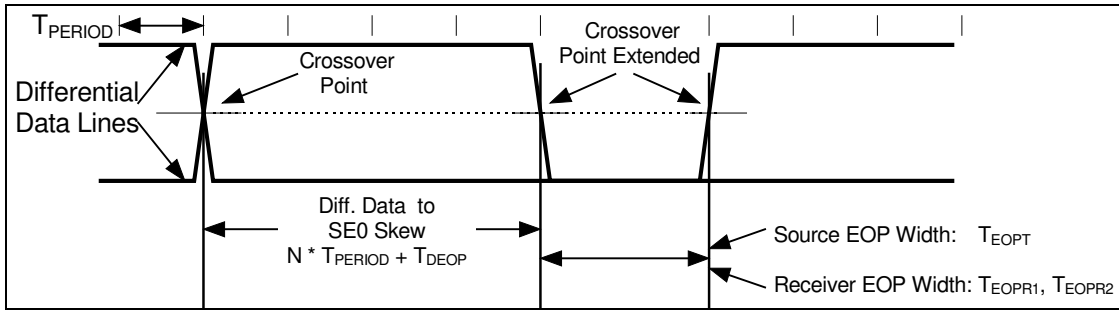

FIGURE 8 - DIFFERENTIAL TO EOP TRANSITION SKEW AND EOP WIDTH

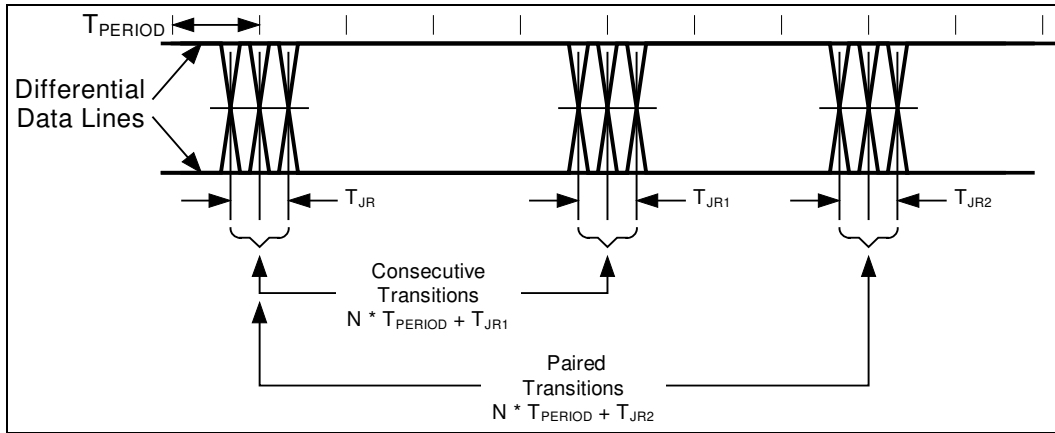

FIGURE 9 - RECEIVER JITTER TOLERANCE

Table 87 - Full Speed (12Mbps) Source Electrical Characteristics

PARAMETER	SYM	CONDITIONS (NOTE 1, 2, 3)	MIN	TYP	MAX	UNIT
DRIVER CHARACTERISTICS:						
Transition Time:		Note 4,5 and FIGURE 5				
Rise Time	TR	CL = 50 pF	4		20	ns
Fall Time	TF	CL = 50 pF	4		20	ns
Rise/Fall Time Matching	TRFM	(TR/TF)	90		110	%
Output Signal Crossover Voltage	VCRS		1.3		2.0	V
Drive Output Resistance	ZDRV	Steady State Drive	28		43	Ω
DATA SOURCE TIMING:						
Full Speed Data Rate	TDRATE	Ave. Bit Rate (12 Mb/s +/- 0.25%) Note 8	11.95		12.03	Mbs
Frame Interval	TFRAME	1.0 ms +/- 0.05%	0.999 5		1.000 5	ms
Clock Period	TPERIOD		80		86	ns
Source Differential Driver Jitter		Note 6, 7 and FIGURE 7				
To next Transition For Paired Transitions	TDJ1 TDJ2		-3.5 -4.0		3.5 4.0	ns ns
Source EOP Width	TEOPT	Note 7 and FIGURE 8	160		175	ns

PARAMETER	SYM	CONDITIONS (NOTE 1, 2, 3)	MIN	TYP	MAX	UNIT
Differential to EOP transition Skew	TDEOP	Note 7 and FIGURE 8	-2		5	ns
Receiver Data Jitter Tolerance		Note 7 and FIGURE 9				
To next Transition For Paired Transitions	TJR1 TJR2		-18.5 -9		18.5 9.0	ns ns
Differential Data Jitter		Note 7 and FIGURE 7				
To next Transition For Paired Transitions	T _x JR1 T _x JR2		-18.5 -9		18.5 9.0	ns ns
EOP Width at receiver		Note 7 and FIGURE 8				
Must reject as EOP	TEOPR1		40			ns
Must Accept	TEOPR2		82			ns
CABLE IMPEDANCE AND TIMING:						
Cable Impedance (Full Speed)	ZO	(45 Ω +/- 15%)	38.75		51.75	Ω
Cable Delay (One Way)	TCBL	FIGURE 6			30	ns

Note 1: All voltages are measured from the local ground potential, unless otherwise specified.

Note 2: All timing use a capacitive load (CL) to ground of 50pF, unless otherwise specified.

Note 3: Full speed timings have a 1.5KΩ pull-up to 2.8 V on the D+ data line.

Note 4: Measured from 10% to 90% of the data signals.

Note 5: The rising and falling edges should be smoothly transiting (monotonic).

Note 6: Timing differences between the differential data signals.

Note 7: Measured at crossover point of differential data signals.

Note 8: These are relative to the 24 MHz crystal.

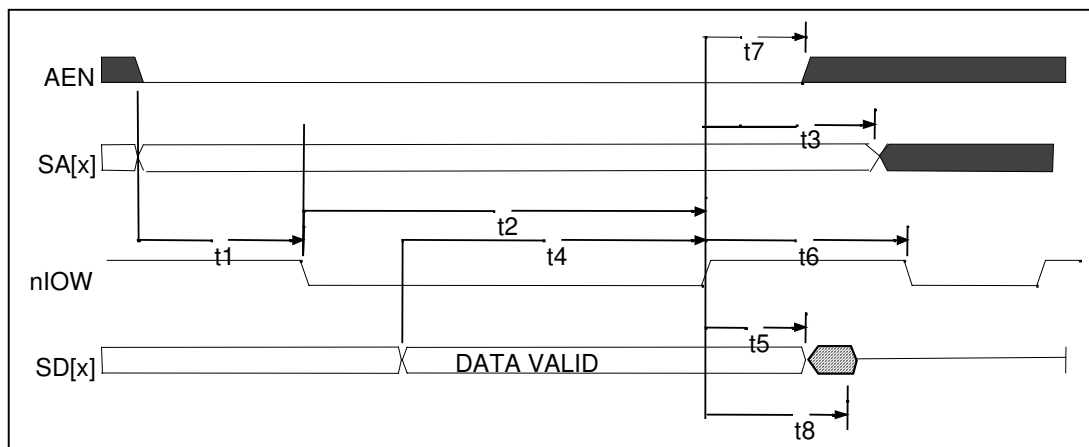

FIGURE 10 - 8051 IO WRITE CYCLE

Table 88 – 8051 IO WRITE Cycle

NAME	DESCRIPTION	MIN	MAX	EQUATION	UNITS
t1	SA[x] and AEN Valid to nIOW Asserted	106		4t-60	ns
t2	nIOW Asserted to nIOW Deasserted	150		6t-100	ns
t3	nIOW Deasserted to SA[x] Invalid	22		t-20	ns
t4	SD[x] Valid to nIOW Deasserted	150		6t-100	ns
t5	SD[x] Hold from nIOW Deasserted	22		t-20	ns
t6	nIOW Deasserted to nIOW Asserted	25			ns
t7	nIOW Deasserted to AEN Deasserted	22		t-20	ns
t8	nIOW Deasserted to SD[x] tri-state		83	2t	ns

Note: Min and Max delays shown for 8051 clk of 24 MHz, to calculate typical timing delays for other clock frequencies use Oscillator Equations, where $t=1/f_{CLK}$.

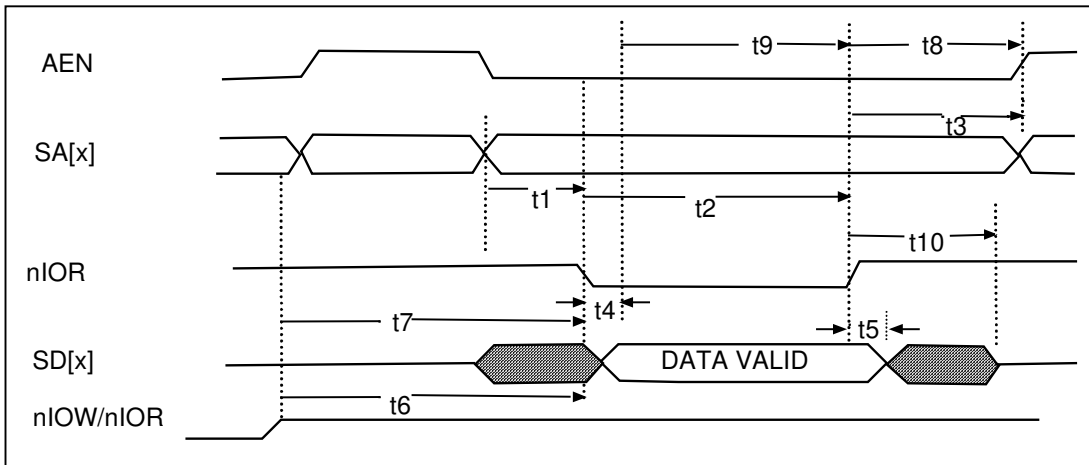

FIGURE 11 – 8051 IO READ CYCLE

Table 89 – 8051 IO Read Timing Parameters

NAME	DESCRIPTION	MIN	MAX	EQUATION	UNITS
t1	SA[x] and AEN Valid to nIOR Asserted	107		4t-60	ns
t2	nIOR Asserted to nIOR Deasserted	150		6t-100	ns
t3	nIOR Asserted to SA[x] Invalid	32		t-10	ns
t4	nIOR Asserted to Data Valid	0			ns
t5	Data Hold/Float from nIOR Deasserted	0			ns
t6	nIOR Asserted after nIOR Deasserted	32		t-10	ns
t7	nIOR Asserted after nIOW Deasserted	32		t-10	ns
t8	nIOR Asserted to AEN Valid	10			ns
t9	Data Valid to nIOR Deasserted	30			ns
t10	nIOR Deasserted to SD[x] tri-state	32		t-10	ns

Note: Min and Max delays shown for 8051 clk of 24 MHz, to calculate typical timing delays for other clock frequencies use Oscillator Equations, where $t=1/f_{CLK}$.

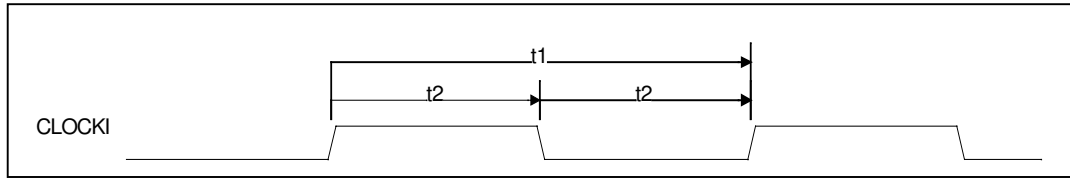

FIGURE 12 - INPUT CLOCK TIMING

Table 90 - Input Clock Timing Parameters

NAME	DESCRIPTION	MIN	TYP	MAX	UNITS
t1	Clock Cycle Time for 24 MHz		41.67		ns
t2	Clock High Time/Low Time for 14.318 MHz	25/16.7		16.7/25	ns
t _r , t _f	Clock Rise Time/Fall Time (not shown)			5	ns

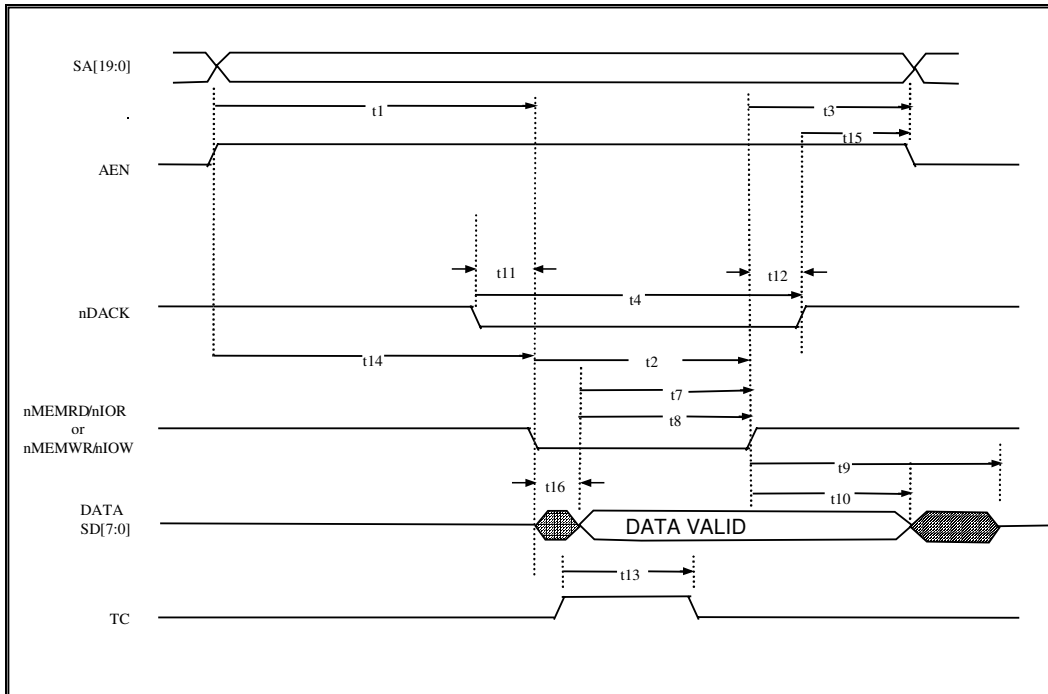

FIGURE 13 - DMA TIMING (SINGLE TRANSFER MODE)

Table 91 - DMA Timing (Single Transfer Mode) Parameters

NAME	DESCRIPTION	MIN	TYP	MAX	UNITS
t1	SA[19:0] Address Setup time to nMEMRD/nIOR or nMEMWR/nIOW Asserted	65			ns
t2	nMEMRD/nIOR or nMEMWR/nIOW Pulsewidth	100			ns
t3	nMEMRD/nIOR or nMEMWR/nIOW deasserted to SA[19:0] Address valid Hold time	30			ns
t4	nDACK Width	150			ns
t7	Data Setup Time to nIOR High	50			ns
t8	Data Set Up Time to nIOW High	40			ns
t9	Data to Float Delay from nIOR High	25		50	ns
t10	Data Hold Time from nIOW High	10			ns
t11	nDACK Set Up to nIOW/nIOR Low	22.5			ns
t12	nDACK Hold after nIOW/nIOR High	22.5			ns
t13	TC Pulse Width	60			ns
t14	AEN Set Up to nIOR/nIOW	40			ns
t15	AEN Hold from nDACK	10			ns
t16	nMEMRD/nIOR or nMEMWR/nIOW asserted to Data valid	0			ns

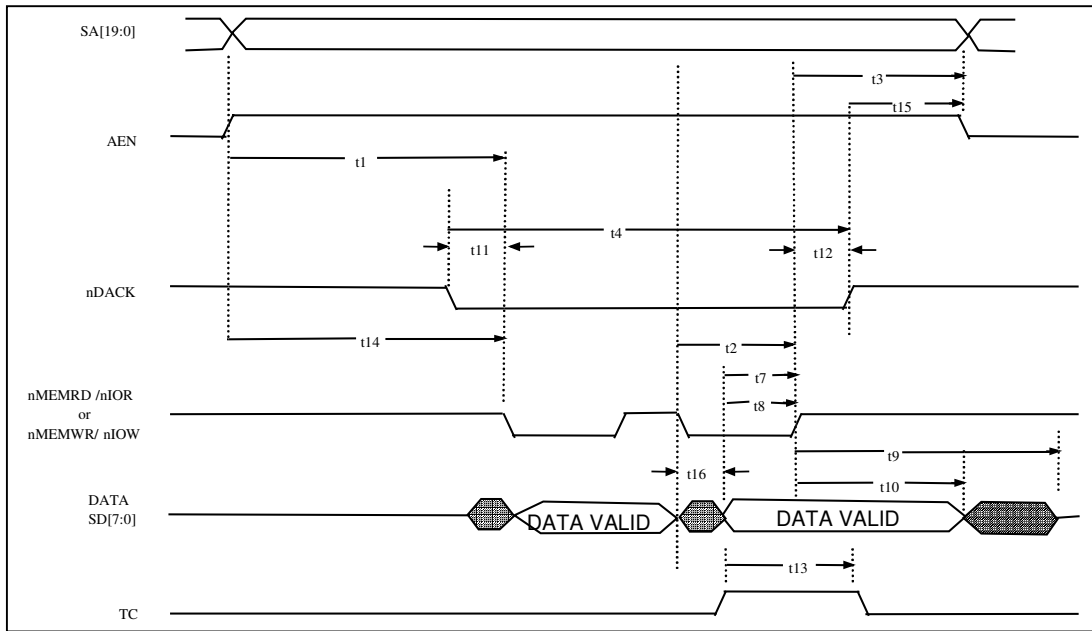

FIGURE 14 - DMA TIMING (BURST TRANSFER MODE)

Table 92 - DMA Timing (Burst Transfer Mode) Parameters

NAME	DESCRIPTION	MIN	TYP	MAX	UNITS
t1	SA[19:0] Address Setup time to nMEMRD/nIOR or nMEMWR/nIOW Asserted	65			ns
t2	nMEMRD/nIOR or nMEMWR/nIOW Pulsewidth	100			ns
t3	nMEMRD/nIOR or nMEMWR/nIOW deasserted to SA[19:0] Address valid Hold time	30			ns
t4	nDACK Width	150			ns
t7	Data Setup Time to nIOR High	50			ns
t8	Data Set Up Time to nIOW High	40			ns
t9	Data to Float Delay from nIOR High	25		50	ns
t10	Data Hold Time from nIOW High	25			ns
t11	nDACK Set Up to nIOW/nIOR Low	22.5			ns
t12	nDACK Hold after nIOW/nIOR High	22.5			ns
t13	TC Pulse Width	60			ns
t14	AEN Set Up to nIOR/nIOW	40			ns
t15	AEN Hold from nDACK	10			ns
t16	nMEMRD/nIOR or nMEMWR/nIOW asserted to Data valid	0			ns

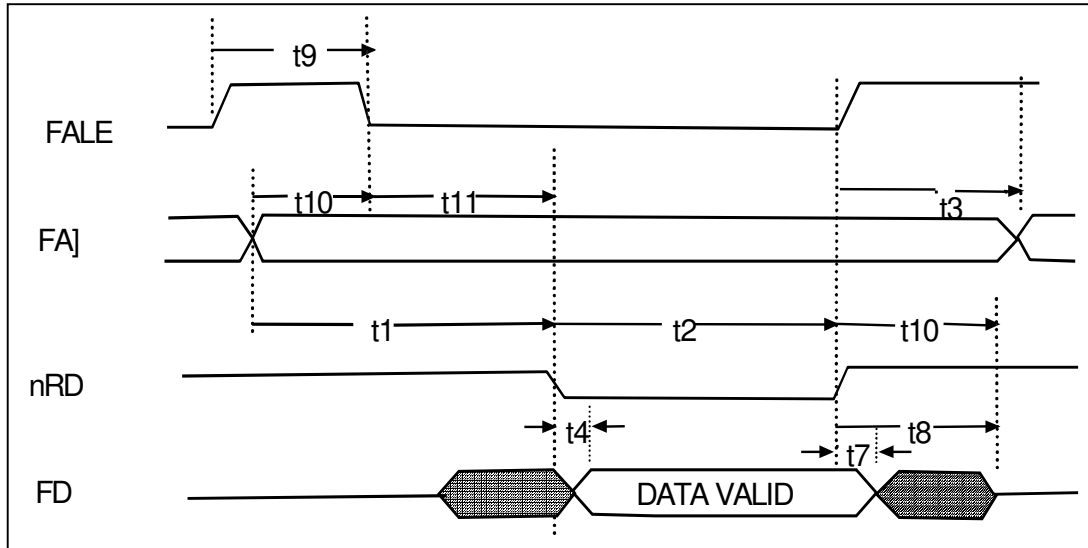

FIGURE 15 - 8051 FLASH PROGRAM FETCH TIMING

Table 93 - 8051 Flash Program Fetch Timing Parameters

	PARAMETER	MIN	TYP	MAX	OSCILLATOR EQUATION	UNITS
t1	FA Valid to nRD asserted	64			$2t-20$	ns
t2	nRD active pulse width	105			$3t-20$	ns
t3	nRD deasserted to FA Invalid	32			$t-10$	ns
t4	nRD asserted to Data Valid	0				ns
t7	FD data Hold from nRD deasserted	0				ns
t8	nRD deasserted to FD data tri-state			32	$t-10$	ns
t9	FALE active pulse width	53			$2t-30$	ns
t10	FA address Valid to FALE deasserted	21.66			$t-20$	ns
t11	FALE deasserted to nRD asserted	21.66			$t-20$	ns

Note: Min and Max delays shown for an 8051 clock of 24MHz, to calculate timing delays for other clock frequencies use the Oscillator Equations, where $T=1/F_{clk}$.

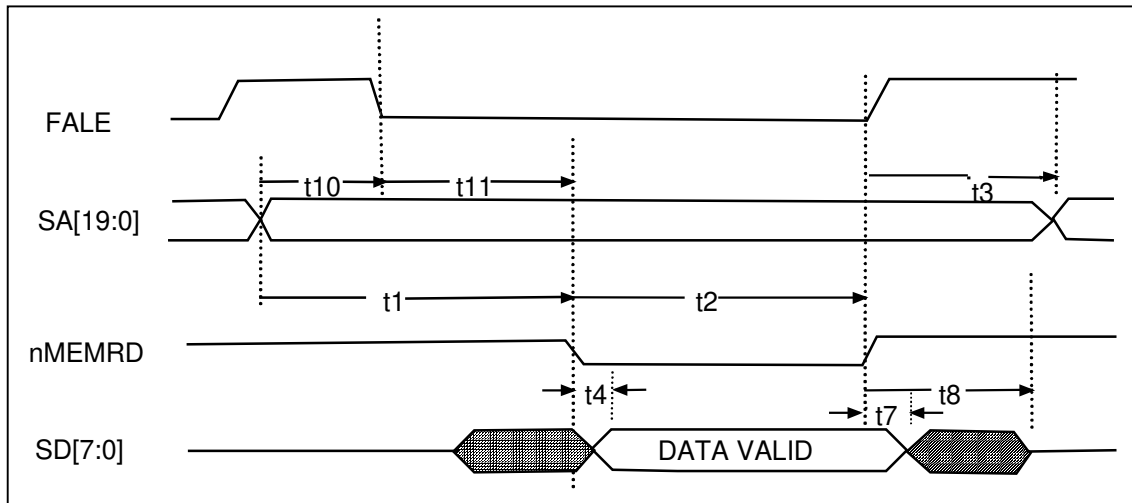

FIGURE 16 - 8051 FLASH MEMORY READ TIMING

Table 94 - 8051 Flash Memory Read Timing Parameters

	PARAMETER	MIN	TYP	MAX	OSCILLATOR EQUATION	UNITS
t1	SA[19:0] Valid to nMEMRD asserted	107			4t-60	ns
t2	nMEMRD active pulse width	150			6t-100	ns
t3	nMEMRD deasserted to SA[19:0] Invalid	21.66			t-20	ns
t4	nMEMRD asserted to Data Valid	0				ns
t7	SD[7:0] data Hold from nMEMRD deasserted	0				ns
t8	nMEMRD deasserted to SD[7:0] data tri-state			64	2t-20	ns
t11	FALE deasserted to nMEMRD asserted	84		165	3t +/- 40	ns

Note: Min and Max delays shown for an 8051 clock of 24MHz, to calculate timing delays for other clock frequencies use the Oscillator Equations, where $T=1/F_{clk}$.

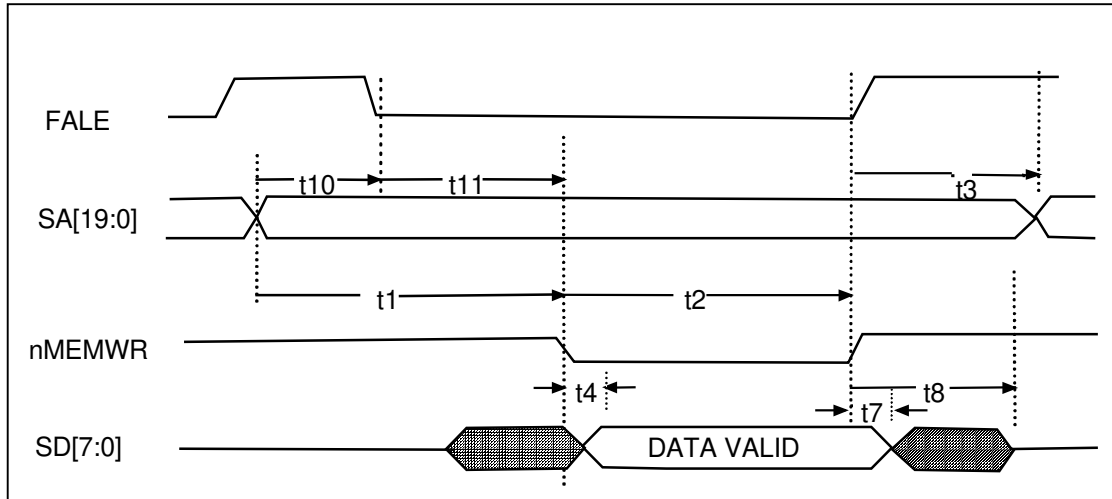

FIGURE 17 - 8051 FLASH MEMORY WRITE TIMING

Table 95 - 8051 Flash Memory Read Timing Parameters

	PARAMETER	MIN	TYP	MAX	OSCILLATOR EQUATION	UNITS
t1	SA[19:0] Valid to nMEMWR asserted	107			4t-60	ns
t2	nMEMWR active pulse width	150			6t-100	ns
t3	nMEMWR deasserted to SA[19:0] Invalid	21.66			t-20	ns
t4	nMEMWR asserted to Data Valid	32			t-10	ns
t7	SD[7:0] data Hold from nMEMWR deasserted	5				ns
t8	nMEMWR deasserted to SD[7:0] data tri-state			64	2t	ns
t11	FALE deasserted to nMEMWR asserted	85		165	3t +/- 40	ns

Note: Min and Max delays shown for an 8051 clock of 24MHz, to calculate timing delays for other clock frequencies use the Oscillator Equations, where $T=1/F_{clk}$.

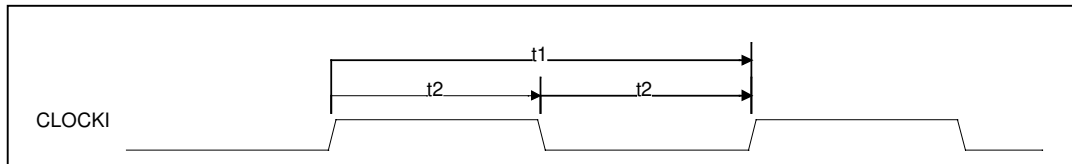

FIGURE 18 - RESET_IN TIMING

Table 96 - Reset_In Timing Parameters

	PARAMETER	MIN	TYP	MAX	UNITS
t1	RESET_IN active pulse width	50			ns

MECHANICAL OUTLINE

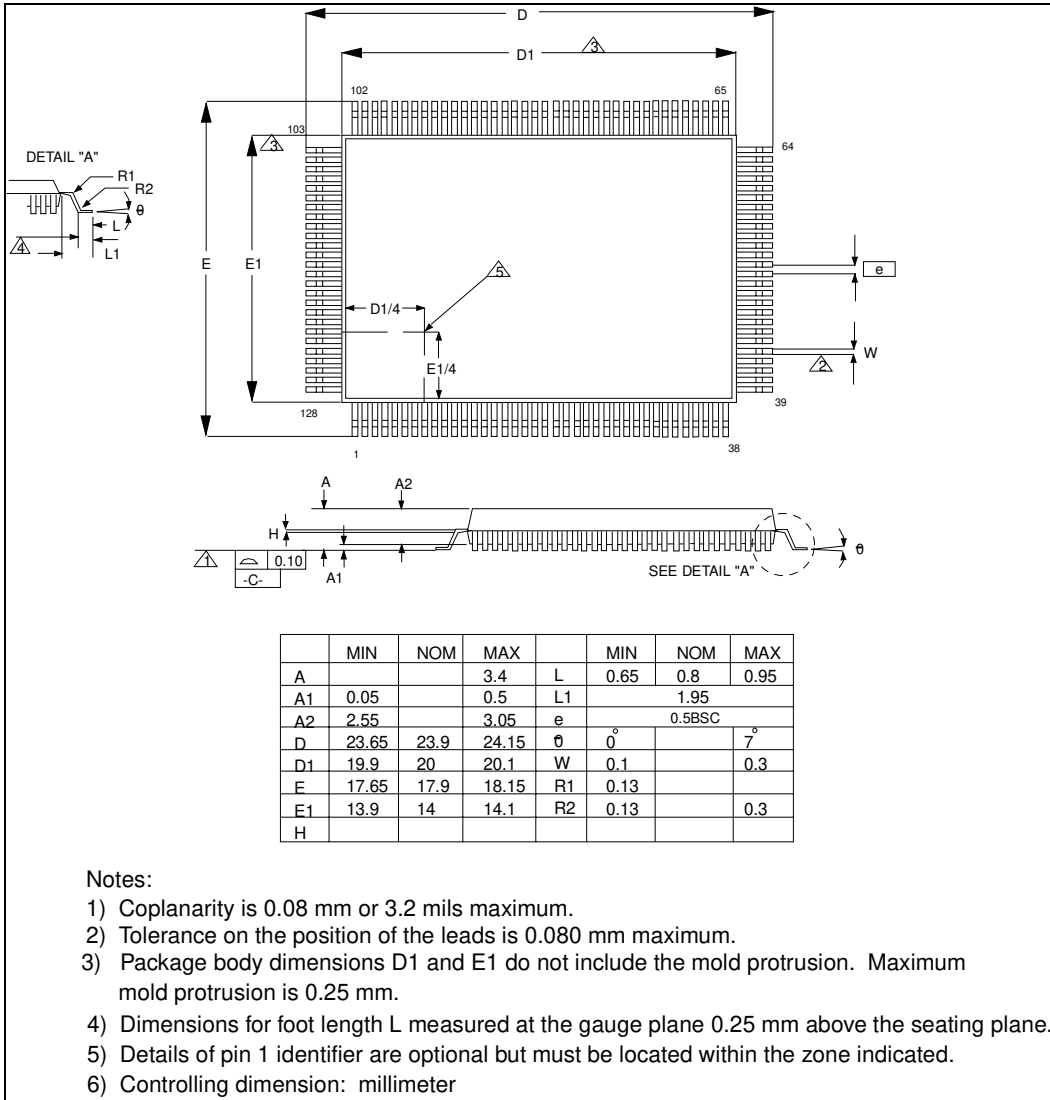

FIGURE 19 - 128 PIN QFP PACKAGE OUTLINE

USB97C100 REVISIONS

PAGE	SECTION/FIGURE/ENTRY	CORRECTION	DATE REVISED
1	FEATURES	“Complete USB Specification 1.0 Compatibility” changed to 1.1 Compatibility	01/03/01
52	DC ELECTRICAL CHARACTERISTICS	Updated suspend, active and initialization current numbers. See italicized text.	02/02/00
5	PIN DESCRIPTION - READY	See Italicized text.	10/8/98
1	FEATURES	Device now supports 3.3V operation. See Italicized text.	6/22/98
6	PIN DESCRIPTION/Power Signals	Device now supports 3.3V operation. See Italicized text.	6/22/98
51	DC ELECTRICAL CHARACTERISTICS	Device now supports 3.3V operation. See Italicized text.	6/22/98
53	CAPACITANCE	Device now supports 3.3V operation. See Italicized text.	6/22/98