

## LTC3558EUD: Linear USB Battery Charger with Buck and Buck-Boost Regulators

### DESCRIPTION

Demonstration Circuit DC1276B is a Linear USB Battery Charger with Buck and Buck-Boost Converters featuring the LTC<sup>®</sup>3558EUD. The LTC3558EUD is a linear battery charger IC for Li-Ion/polymer battery applications, with a general purpose synchronous step-down switching regulator and a general purpose buck-boost regulator. For USB powered applications, the battery charge current can be limited to 500mA, by setting  $R_{\text{PROG}}$  to 1.74 k $\Omega$ . For non-USB powered applications, the charge current can be set as high as

950mA, by simply changing  $R_{\text{PROG}}$ . The buck and the buck-boost switching regulators can deliver up to 400mA load current, each. The LTC3558EUD is available in 20-pin (3mm  $\times$  3mm) QFN surface mount package.

Design files for this circuit board are available, call the LTC factory.

 , LTC and LT are registered trademarks of Linear Technology Corporation. PowerPath is a trademark of Linear Technology Corporation.

### PERFORMANCE SUMMARY Specifications are at $T_{\text{A}} = 25^{\circ}\text{C}$

SYMBOL	PARAMETER	CONDITIONS	MIN	TYP	MAX	UNITS
$V_{\text{CC}}$	Input voltage range		4.35		5.5	V
VFLOAT	BAT float voltage	Constant Voltage mode	4.15		4.23	V
IBAT	Battery charge current	Constant current mode, $R_{\text{PROG}} = 1.74\text{k}\Omega$ , HPWR=HI	0.46		0.5	A
VOUT1	Buck regulator output voltage	$\text{IOUT1} \leq 400\text{mA}$	1.17		1.23	V
VOUT2	Buck-Boost regulator output voltage	$\text{IOUT2} \leq 400\text{mA}$	3.27		3.33	V

### QUICK START PROCEDURE

Demo Circuit DC1276B is best evaluated using a Li-Ion or Li-Polymer battery. When using a battery simulator for evaluation, oscillations must be verified with a real battery at the same conditions because it is difficult to match the impedance of a real battery. Capacitor C10 was added to simulate the low impedance of a real battery. It will allow proper operation of the demo circuit with or without a battery and even with a battery simulator consisting of a power supply in parallel with a 3.6 Ohm resistor.

Refer to Figure 1 for the proper measurement equipment setup and jumper settings and follow the procedure below.

**NOTE.** When measuring the input or output voltage ripple, care must be taken to avoid a long ground lead on the oscilloscope probe. Measure the input or output voltage ripple by touching the probe tip directly across the  $V_{\text{CC}}$  or  $V_{\text{OUT}}(\text{x})$  and GND terminals. See Figure 2 for proper scope probe technique.

1. Set PS1 to 5.0V, and PS2 to 3.6V.
2. Observe AM1, AM4, VM2, VM3, VM4, VM5, and VM6.

# QUICK START GUIDE FOR DEMONSTRATION CIRCUIT DC1276B HIGH EFFICIENCY USB POWER MANAGER WITH BUCK AND BUCK-BOOST REGULATORS

## LTC3558EUD

3. Set the HPWR jumper (JP1) to “20%”. Observe AM1 and AM4.
4. Set the NTC jumper (JP3) to “EXT”. Observe VM3. The “CHRG” LED (D1) should be blinking.
5. Set the HPWR jumper (JP1) to “100%”, the SUSP jumper (JP2) to “OFF” and the NTC jumper (JP3) to “INT”.
6. Set Ld1 to 400mA. Observe VM4 and AM2. Set Ld1 to 0mA.
7. Set Ld2 to 400mA. Observe VM5 and AM3. Set Ld2 to 0mA.
8. Set EN1 (JP4) and EN2 (JP5) to “OFF”. Observe VM4 and VM5.

## OPERATING PRINCIPLES

The LTC3558 is composed of 3 major functional blocks working together: Battery Charger, Buck Regulator, and Buck-Boost Regulator.

### The Battery Charger

The battery charger is a linear Li-Ion battery charger that operates in constant current mode, until the battery voltage rises to approximately the FLOAT voltage, of 4.2V, and then the charger switches to constant voltage mode.

The charge current is programmed by the PROG (R6) resistor, and has been set to 500mA, on DC1276B, with a 1.74k $\Omega$  resistor. The HPWR pin is used to select 20% or 100% of the programmed charge current. The charge current delivered is nominally the programmed current, so if the application requires compliance with the USB specification of presenting a 100mA/500mA or **less** load, the nominal charge current must be set to accommodate the full distribution of actual charge currents.

The battery charger implements trickle charging, for initial battery voltages less than 2.9V. It also imple-

ments a charge termination timeout of 4 hours, and a bad cell charging timeout of 30 minutes. An NTC input is used to determine if the battery temperature is suitable for charging, too hot or too cold.

The state of charge, as well as any faults, is signaled with the  $\overline{\text{CHRG}}$  pin.

### Buck Regulator

The general purpose 400mA buck regulator is implemented as a current mode, synchronous rectifier regulator, operating at 2.25MHz. Step response is excellent and output ripple is very low.

### Buck Regulator Transient Response, Pulse Skip Mode

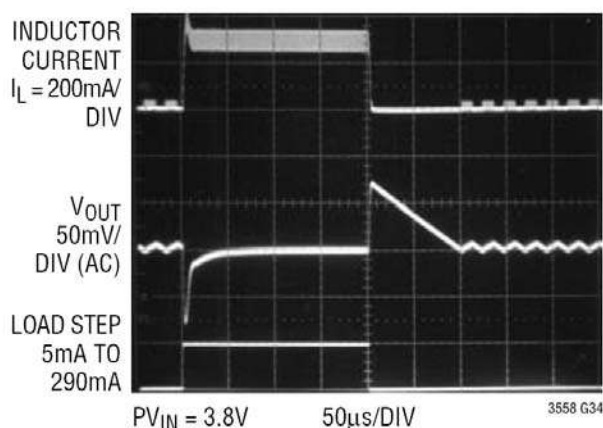

### Buck-Boost Regulator

The general purpose 400mA buck-boost regulator is implemented as a voltage mode regulator, operating at 2.25MHz. A type three compensation is recommended for this regulator to achieve the best performance.

## APPLICATION INFORMATION

This demo circuit is designed to demonstrate the full capability of the device. Not all components are required in all applications. The critical circuit components are on the top of the board near the IC.

The VCC input capacitor network of C1 and R1 is used to dampen input source inductances that

commonly occur in laboratory setups with twisted leads and a bench power supply. When using a USB cable or adaptor cable this input damping network will likely not be required. Please note that the in-circuit capacitance of the specified 10 $\mu$ F, 0603 ceramic capacitor for C1 is approximately 5 $\mu$ F each at 5V.

Capacitor C9 is included to simulate a low impedance battery. It is especially helpful when testing the demo circuit with a battery simulator comprised of a power supply with a 3.6 Ohm power resistor across it. The leads connecting the power supply to the demo circuit should be a twisted pair to minimize lead inductance; although, even twisted pairs can introduce enough inductance into the circuit to turn on overshoot without damping resistor R17.

#### **Power dissipation**

The LTC3558 implements a linear battery charger with no pre-regulator. The battery charge current can be set as high as 0.95A, by choosing the appropriate PROG (R6) resistor.

For a typical application of USB charging of a battery, VCC = 5V, BAT = 3V. The  $\theta_{JA}$  of the package is 68°C/W, and the maximum  $T_J$  is 125°C. Thus, for  $T_A(\text{max}) = 50^\circ\text{C}$  the maximum charge current without thermal regulation can be as high as 550mA.

If a higher charge current is desired, the PROG resistor (R6) can be changed. If the resultant power dissipation exceeds the package dissipation rating the LTC3558 will go into thermal regulation, and reduce charge current to an acceptable level.

# QUICK START GUIDE FOR DEMONSTRATION CIRCUIT DC1276B HIGH EFFICIENCY USB POWER MANAGER WITH BUCK AND BUCK-BOOST REGULATORS

## LTC3558EUD

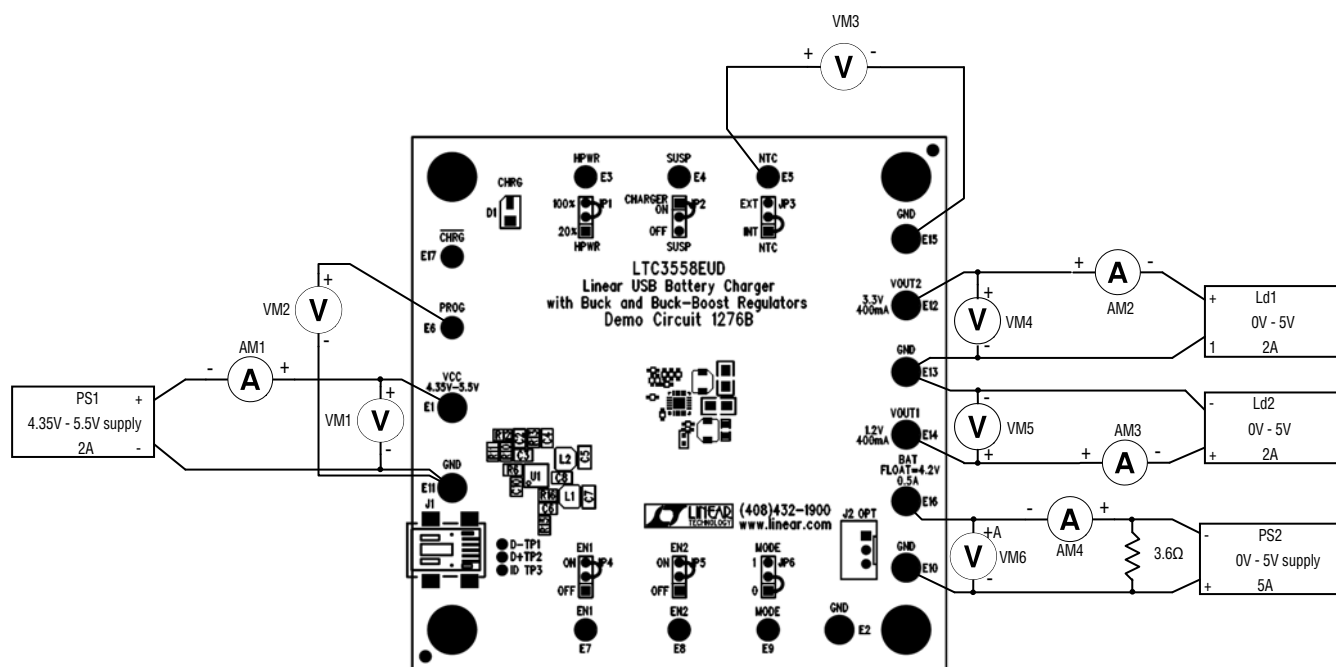

Note: All connections from equipment should be Kelvin connected directly to the board pins which they are connected on this diagram and any input or output leads should be twisted pair.

**Figure 1. Proper Measurement Equipment Setup for DC1276B**

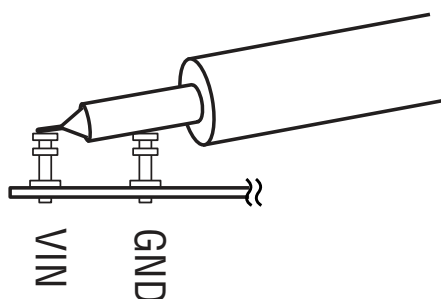

**Figure 2: Measuring Input or Output Ripple**

# QUICK START GUIDE FOR DEMONSTRATION CIRCUIT DC1276B HIGH EFFICIENCY USB POWER MANAGER WITH BUCK AND BUCK-BOOST REGULATORS

## LTC3558EUD

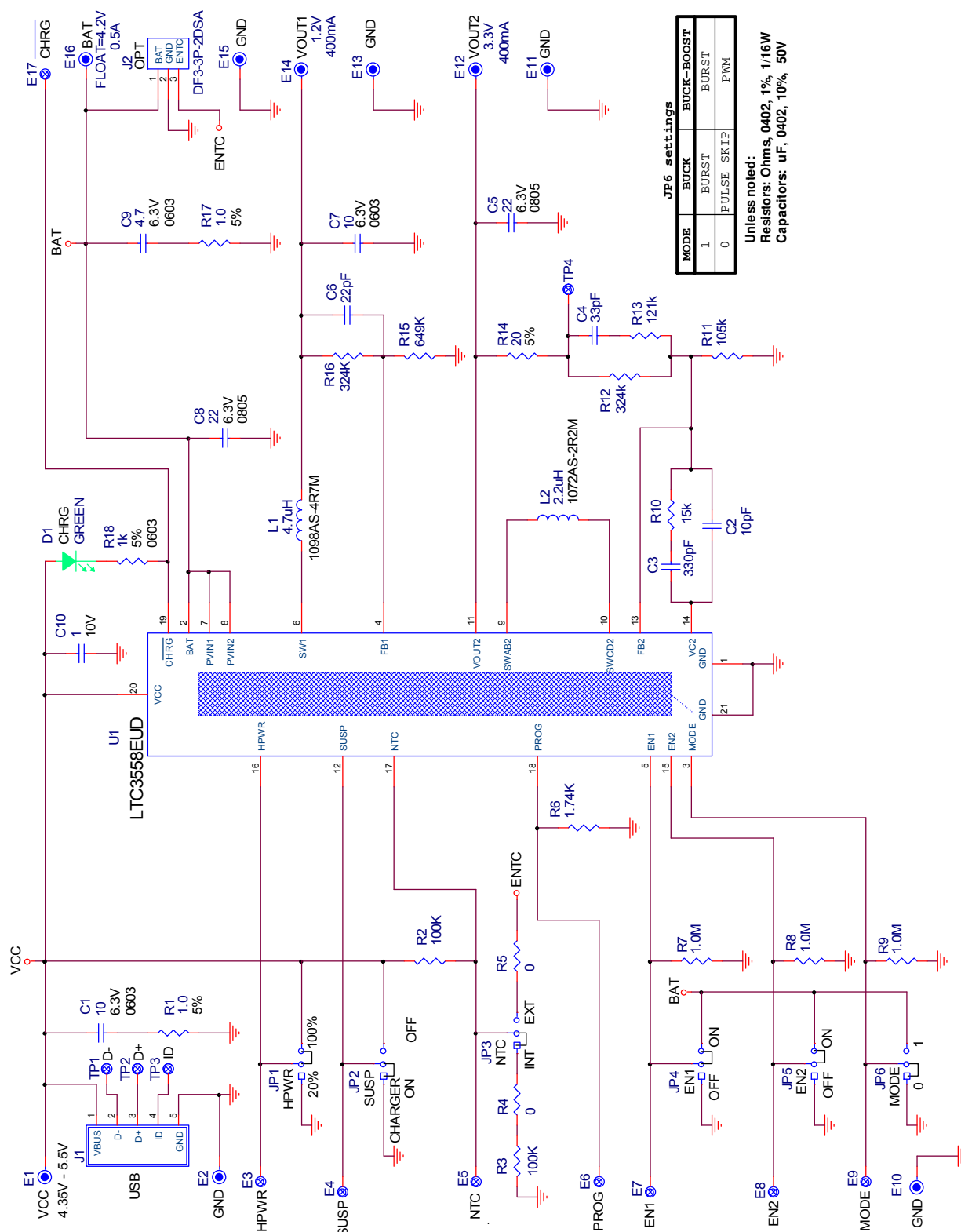

Figure 3: Circuit Schematic

# QUICK START GUIDE FOR DEMONSTRATION CIRCUIT DC1276B HIGH EFFICIENCY USB POWER MANAGER WITH BUCK AND BUCK-BOOST REGULATORS

## LTC3558EUD

Qty	Reference	Part Description	Manufacture / Part #
<b>REQUIRED CIRCUIT COMPONENTS:</b>			
1	C2	CAP, CHIP, COG, 10pF, $\pm 0.5\text{pF}$ , 50V, 0402	VISHAY, VJ0402A100DXAA
2	C3	CAP, CHIP, BX, 330pF, $\pm 5\%$ , 50V, 0402	VISHAY, VJ0402X331JXAA
3	C4	CAP, CHIP, COG, 33pF, $\pm 5\%$ , 50V, 0402	VISHAY, VJ0402A330JXAA
4	C5,C8	CAP, CHIP, X5R, 22 $\mu\text{F}$ , $\pm 20\%$ , 6.3V, 0805	MURATA, GRM21BR60J226ME39L
5	C6	CAP, CHIP, COG, 22pF, $\pm 5\%$ , 50V, 0402	MURATA, GRM1555C1H220J
6	C7	CAP, CHIP, X5R, 10 $\mu\text{F}$ , $\pm 20\%$ , 6.3V, 0603	MURATA, GRM188R60J106ME47D
7	C10	CAP, CHIP, X5R, 1.0 $\mu\text{F}$ , $\pm 10\%$ , 10V, 0402	MURATA, GRM155R1A105KE15D
8	L1	IND, SMT, 4.7 $\mu\text{H}$ , 155m $\Omega$ , $\pm 20\%$ , 1.2A, 3.0mmX3.2mm	TOKO, 1098AS-4R7M
9	L2	IND, SMT, 2.2 $\mu\text{H}$ , 39m $\Omega$ , $\pm 20\%$ , 1.8A, 2.8mmX3.0mm	TOKO, 1072AS-2R2M
10	R6	RES, CHIP, 1.74k $\Omega$ , $\pm 1\%$ , 1/16W, 0402	VISHAY, CRCW04021K74FKED
11	R10	RES, CHIP, 15k $\Omega$ , $\pm 1\%$ , 1/16W, 0402	VISHAY, CRCW040215K0FKED
12	R11	RES, CHIP, 105k $\Omega$ , $\pm 1\%$ , 1/16W, 0402	VISHAY, CRCW0402105KFKED
13	R12,R16	RES, CHIP, 324k $\Omega$ , $\pm 1\%$ , 1/16W, 0402	VISHAY, CRCW0402324KFKED
14	R13	RES, CHIP, 121k $\Omega$ , $\pm 1\%$ , 1/16W, 0402	VISHAY, CRCW0402121KFKED
15	R15	RES, CHIP, 649k $\Omega$ , $\pm 1\%$ , 1/16W, 0402	VISHAY, CRCW0402649KFKED
16	U1	Linear USB Battery Charger with Buck and Buck-Boost Regulators	LINEAR TECH., LTC3558EUD
<b>ADDITIONAL DEMO BOARD CIRCUIT COMPONENTS:</b>			
1	C1	CAP, CHIP, X5R, 10 $\mu\text{F}$ , $\pm 20\%$ , 6.3V, 0603	MURATA, GRM188R60J106ME47D
2	C9	CAP, CHIP, X5R, 4.7 $\mu\text{F}$ , $\pm 20\%$ , 6.3V, 0603	MURATA, GRM188R60J475KE19D
3	D1	DIODE, LED, GREEN, SMT, 1206	PANASONIC, LN1351CTR
4	R1,R17	RES, CHIP, 1.0 $\Omega$ , $\pm 5\%$ , 1/16W, 0402	VISHAY, CRCW04021R00JNED
5	R2,R3	RES, CHIP, 100k $\Omega$ , $\pm 5\%$ , 1/16W, 0402	VISHAY, CRCW0402100KFKED
6	R4,R5	RES, CHIP, 0 $\Omega$ jumper, 1/16W, 0402	VISHAY, CRCW04020000Z0ED
7	R7,R8,R9	RES, CHIP, 1MEG $\Omega$ , $\pm 1\%$ , 1/16W, 0402	VISHAY, CRCW04021M00FKED
8	R14	RES, CHIP, 20 $\Omega$ , $\pm 1\%$ , 1/16W, 0402	VISHAY, CRCW040220R0FNED
9	R18	RES, CHIP, 1k $\Omega$ , $\pm 5\%$ , 1/16W, 0603	VISHAY, CRCW06031K00JNED
<b>HARDWARE FOR DEMO BOARD ONLY:</b>			
1	J1	CONN, USB Mini-B	TYCO, 1734035-2
2	J2-OPT	CONN, Li-Ion battery	HIROSE, DF3-3P-2DSA
3	JP1,JP2,JP3,JP4,JP5,JP6	HEADER, 3 PINS, 2mm	SAMTEC, TMM-103-02-L-S
4	JP1,JP2,JP3,JP4,JP5,JP6	SHUNT 2MM	SAMTEC, 2SN-BK-G
5	E1,E2,E10,E11,E12,E13 E14,E15,E16	TURRET, 0.09 DIA	MILL-MAX, 2501-2-00-80-00-00-07-0
6	E3,E4,E5,E6,E7,E8,E9,E17	TURRET, 0.061 DIA	MILL-MAX, 2308-2-00-80-00-00-07-0

Figure 4: Bill of Materials