

PART NUMBER	REV	FIRST USED
1852140-1	A	854400-1
1852140-2	A	565435-5

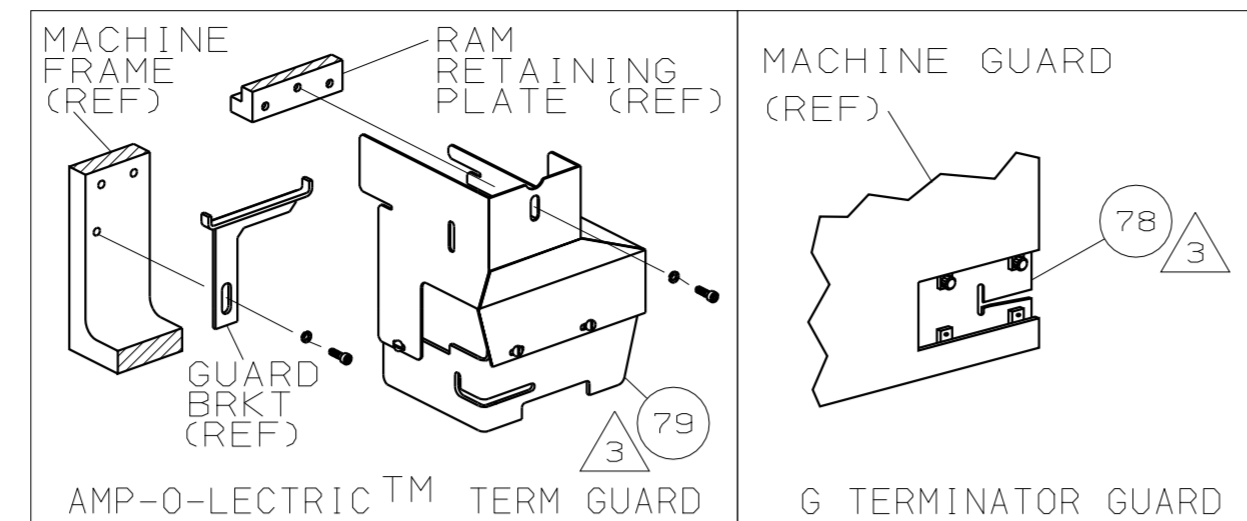

TYCO TERM P/N		MFG TERM P/N		AMP TERMINAL		AMP CRIMP SPECS	
PAD LTR	CRIMP HEIGHT	WIRE SIZE	WIRE	SIZE	TYPE	RANGE	INSUL
A	.080 ±.002 [2.03 ±0.05mm]	2.5mm ²			F	1.0-2.5mm ²	
B	.075 ±.002 [1.91 ±0.05mm]	2.0mm ²			F	1.0-2.5mm ²	
C	.069 ±.002 [1.75 ±0.05mm]	1.5mm ²			F	1.0-2.5mm ²	
D	.063 ±.002 [1.60 ±0.05mm]	1.0mm ²			F	1.0-2.5mm ²	

-1 LEADMAKER & BENCH MODEL G		MECH POST FEED	
-2 BENCH MODEL K		MECH POST FEED	

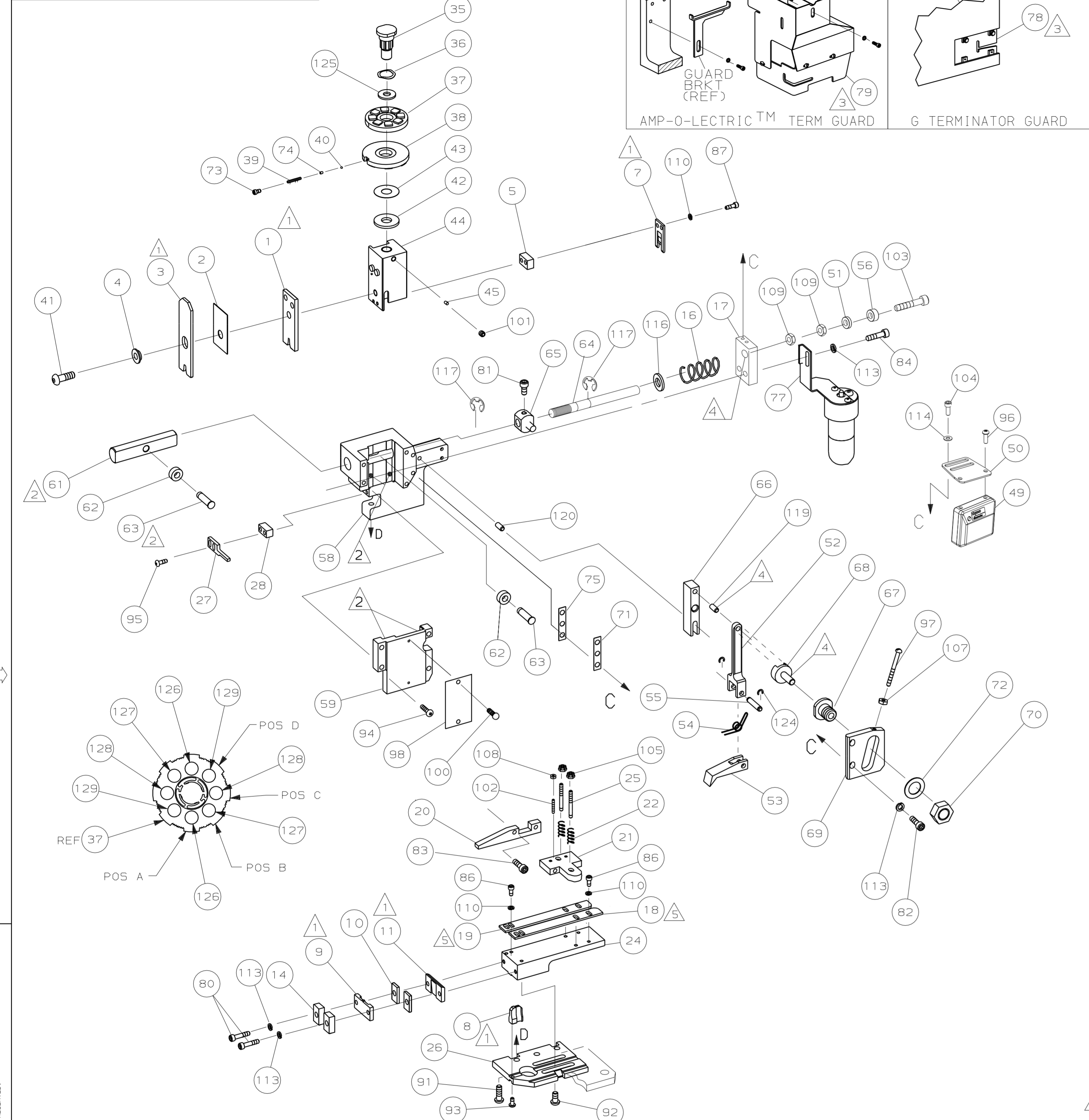

WIRE STRIP LENGTH	TERM APPL	SPEC	FEED	APPL INSTRUCTION	SET UP GAGE	LAYOUT
.188-.203	NONE		.748	408-8039	458638-1	L4029

QTY	TERMS	REF	DESCRIPTION	ITEM NO		
2	2	-	C	1-354779-8	PIN, WIRE DISC (.3080)D	129
2	2	-	C	354779-6	PIN, WIRE DISC (.3020)C	128
2	2	-	C	9-354778-3	PIN, WIRE DISC (.2960)B	127
2	2	-	C	8-354778-1	PIN, WIRE DISC (.2900)A	126
1	1	-	A	986950-1	WASHER, FLAT PRECISION	125
2	2	-	A	21045-3	RING, RET "C" (φ.187)FD PIN	124
						123
						122
						121
1	1	-	A	1-21030-7	PIN, DOWEL (φ.187x1.50)HSG	120
1	1	-	A	1-21030-1	PIN, DOWEL (φ.187x.50)LEVER	119
						118
2	2	-	A	1-21046-6	RING, RETAINING, EXT (5/16)FD ADJ ROD	117
1	1	-	A	21899-4	WASHER, FLAT (φ5/16) SCR ADJ	116
						115
2	2	-	A	18028-2	WASHER, FLAT (M4) COUNTER	114
6	6	-	A	21024-5	WASHER, LOCK (NO. 10) SHEAR PL	113
						112
						111
6	6	-	A	21024-4	WASHER, LOCK (NO. 8) SHEAR BL	110
2	2	-	A	22593-1	NUT, HEX (1/4-20) MAGNET	109
2	2	-	A	21018-4	NUT, HEX (4-40) DRAG	108
1	1	-	A	21018-5	NUT, HEX (6-32)FD ADJ PL	107
						106
2	2	-	A	21022-2	NUT, HEX 5L (8-32)DRAG STUD	105
2	2	-	A	9-21000-9	SCR, SHC (8-32x.44) COUNTER	104
1	1	-	A	3-21081-3	SCR, SHC (1/4-20x1.25) MAGNET	103
2	2	-	A	2-21006-6	SCR, SKT SET (4-40x.62) DRAG	102
1	1	-	A	21009-2	SCR, SKT SET (1/4-20x.25) RAM	101
2	2	-	A	21017-2	SCR, DRIVE (#2x.19) ID PLATE	100
1	1	-	A	1-21002-7	SCR, BHC (6-32x.38) CAM	99
1	1	-	B	461264-1	PLATE, IDENTIFICATION	98
1	1	-	A	6-23715-5	SCR, PAN HD (6-32x1.50) FEED ADJ	97
2	2	-	A	994991-5	SCR, OVAL HD (M4X12) COUNTER	96
2	2	-	A	2-21002-2	SCR, BHC (8-32x.50) STRIPPER	95
4	4	-	A	3-21002-0	SCR, BHC (10-32x.87) HSG CAP	94
1	1	-	A	22733-8	SCR, BHC (8-32x.38 LW) ANVIL	93
4	4	-	A	3-21002-3	SCR, BHC (1/4-20x.50) ST 6D PL	92
3	3	-	A	2-22733-8	SCR, BHC (1/4-20x.62) BASE PL	91
						90
						89
						88
						87
2	2	-	A	2-21000-6	SCR, SHC (8-32x.38) SLUG BLADE	86
4	4	-	A	2-21000-7	SCR, SHC (8-32x.50) STRIP GUIDE	85
						84
2	2	-	A	3-21000-7	SCR, SKT CAP (10-32x.75) FD GDE	83
2	2	-	A	1-21000-3	SCR, SHC (4-40x.25) DRAG	82
2	2	-	A	3-21000-6	SCR, SKT CAP (10-32x.62) FD ADJ P	81
1	1	-	A	3-21000-4	SCR, SKT CAP (10-32x.38) PIVOT BL	80
2	2	-	A	4-21000-0	SCR, SKT CAP (10-32x1.25) SH PL	79
1	-	-	A	1-455750-1	GUARD ASSY	78
-	REF	-	A	679532-1	INSERT, GUARD	77
1	-	-	C	465184-9	LUBRICATOR ASSY	76
						75
1	1	-	A	238305-5	SPACER, ADJ PLATE	74
1	1	-	A	690603-1	SPRING, ASSIST	73
1	1	-	A	23030-1	SCR, SKT CAP (6-32x.25) CP DSC	72
1	1	-	A	458109-1	WASHER, FLAT (SPECIAL)	71
1	1	-	A	690517-1	SPACER	70

QTY	TERMS	REF	DESCRIPTION	ITEM NO		
				60		
1	1	-	C	458268-1	CAP, RAM	59
1	1	-	D	458267-1	HOUSING	58
					57	
1	1	-	A3	1804299-1	SPACER, MAGNET	56
1	1	-	B	240624-1	PIN, FEED FINGER	55
1	1	-	B	691499-1	SPRING, FEED FINGER	54
1	1	-	B	694921-5	FINGER, FEED	53
1	1	-	B	240634-3	LEVER, TERMINAL	52
1	1	-	A	1804310-1	MAGNET, RING	51
1	1	-	A	1804303-1	BRACKET, COUNTER MOUNTING	50
1	1	-	A	1804300-1	APPLICATOR COUNTER ASSEMBLY	49
1	-	-	B	690501-3	CAM, POST FEED 1 1/8 ST	48
-	1	-	B	690501-4	CAM, POST-FEED 1 5/8 ST	47
					46	
1	1	-	A	690191-1	PLUG, NYLON	45
1	1	-	C	458266-2	RAM	44
1	1	-	A	690125-1	WASHER, LAMINATED	43
1	1	-	A	690124-3	WASHER, RAM	42
1	1	-	A	7-21002-9	BOLT, CRIMPER (5/16-24x1.00)	41
1	1	-	A	23241-6	BALL, STEEL	40
1	1	-	A	690170-1	SPRING, COMPRESSION	39
1	1	-	C	690142-1	DISC, INSULATION	38
1	1	-	D	354777-1	WIRE DISC, PLASTIC	37
1	1	-	A	22480-5	WASHER, SPRING	36
1	1	-	B	690212-1	POST, RAM	35
					34	
					33	
					32	
					31	
					30	
					29	
1	1	-	B	2-690451-4	SPACER, STRIPPER	28
1	1	-	A	468281-1	STRIPPER	27
1	1	-	C	463915-1	PLATE, BASE	26
2	2	-	A	22354-8	DRAG, STUD	25
1	1	-	B	463903-1	PLATE, STRIP GUIDE	24
					23	
2	2	-	A	2-22281-3	SPRING, DRAG	22
1	1	-	B	464451-2	ARM, STOCK DRAG	21
1	1	-	A	1-464452-1	DRAG, STOCK	20
1	1	-	B	6-458030-1	GUIDE, STRIP (REAR)	19
1	1	-	C	6-458031-1	GUIDE, STRIP (FRONT)	18
1	1	-	A	1804305-2	GUIDE, FEED ROD	17
1	1	-	A	4-22284-9	SPRING, FEED RETURN	16
					15	
2	2	-	B	469633-3	BLOCK, SUPPORT	14
					13	
					12	
1	1	-	B	458255-1	PLATE, REAR SHEAR	11
2	2	-	B	1-240645-8	SPACER, SHEAR PLATE	10
1	1	-	B	455961-5	PLATE, FRONT SHEAR	9
1	1	-	D	8-356038-5	ANVIL	8
1	1	-	B	1-469634-2	BLADE, SLUG	7
					6	
1	1	-	C	1-238075-9	SPACER, SLUG BLADE	5
1	1	-	B	238009-1	SPACER, BLOCK CRIMPER	4
1	1	-	C	464113-5	CRIMPER, INSULATION	3
1	1	-	B	2-455888-4	SPACER, CRIMPER	2
1	1	-	C	1-464112-5	CRIMPER, WIRE	1

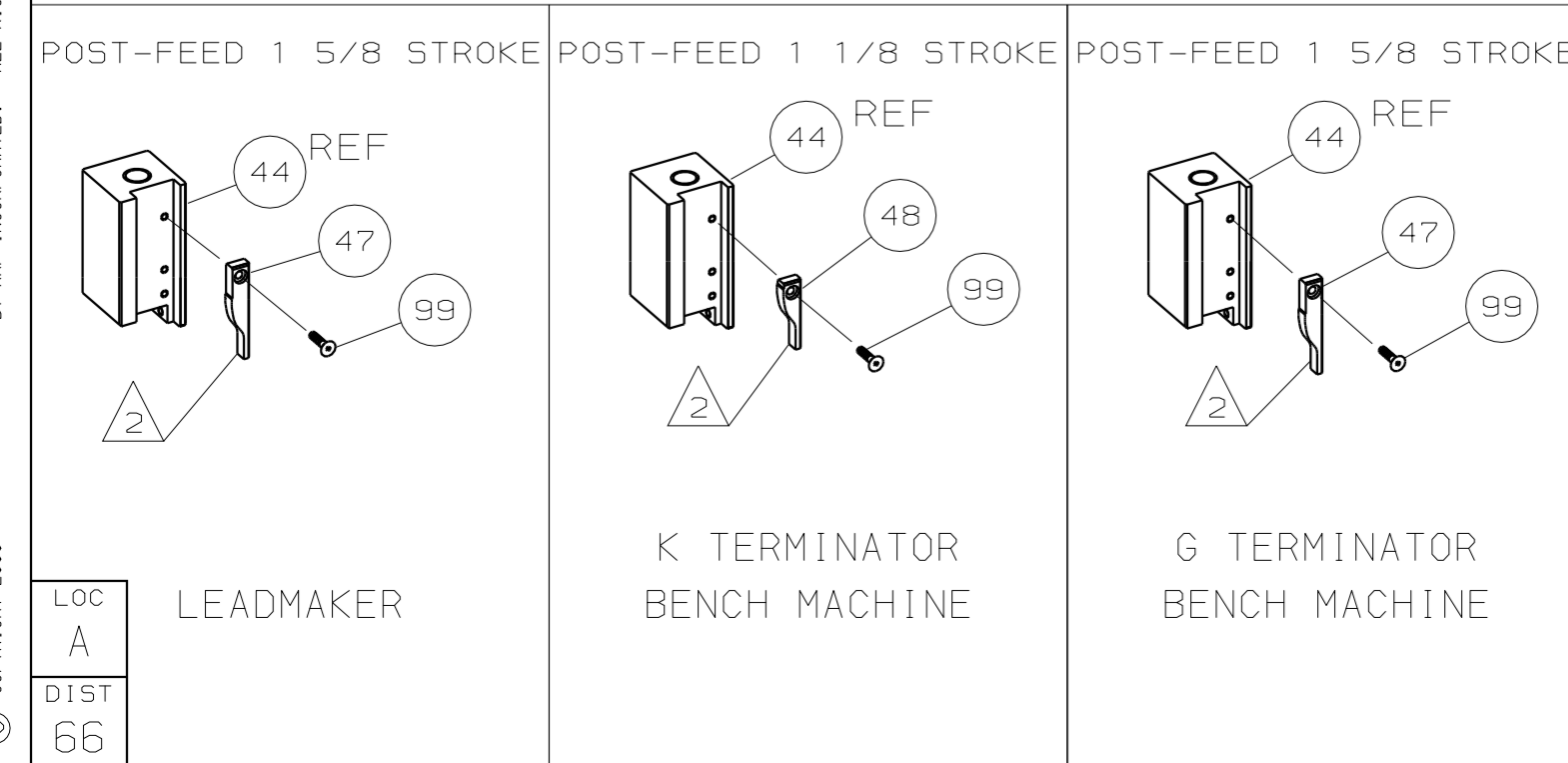

- 1 RECOMMENDED SPARE PARTS.
- 2 GREASE LIGHTLY.
- 3 GUARD MUST BE IN PLACE WHEN OPERATING APPLICATOR IN A BENCH MACHINE.
- 4 LUBRICATE DAILY USING NO. 20 MACHINE OIL.
- 5 STRIP GUIDE ADJUSTMENT REQUIRED TO CONVERT FROM LEFT TO RIGHT HAND TERMINALS OR VISE-VERSA.
- 6 ITEM 78 USED WITH G TERMINATOR ONLY.

QTY	REF	DESCRIPTION	ITEM NO
-2	-1	U/M DWG SIZE	
		PART NO	
		DESCRIPTION	
		ITEM NO	

QTY	REF	DESCRIPTION	ITEM NO
-2	-1	U/M DWG SIZE	
		PART NO	
		DESCRIPTION	
		ITEM NO	