

THIS DRAWING IS UNPUBLISHED. RELEASED FOR PUBLICATION 20  
 © COPYRIGHT 20 BY - ALL RIGHTS RESERVED.

LOC	DIST	REVISIONS			
P	LTR	DESCRIPTION	DATE	DWN	APVD
	A	RELEASED	25NOV2011	T.K	H.K
	A1	REVISED (ECR-12-003980)	01MAR2012	T.K	H.K

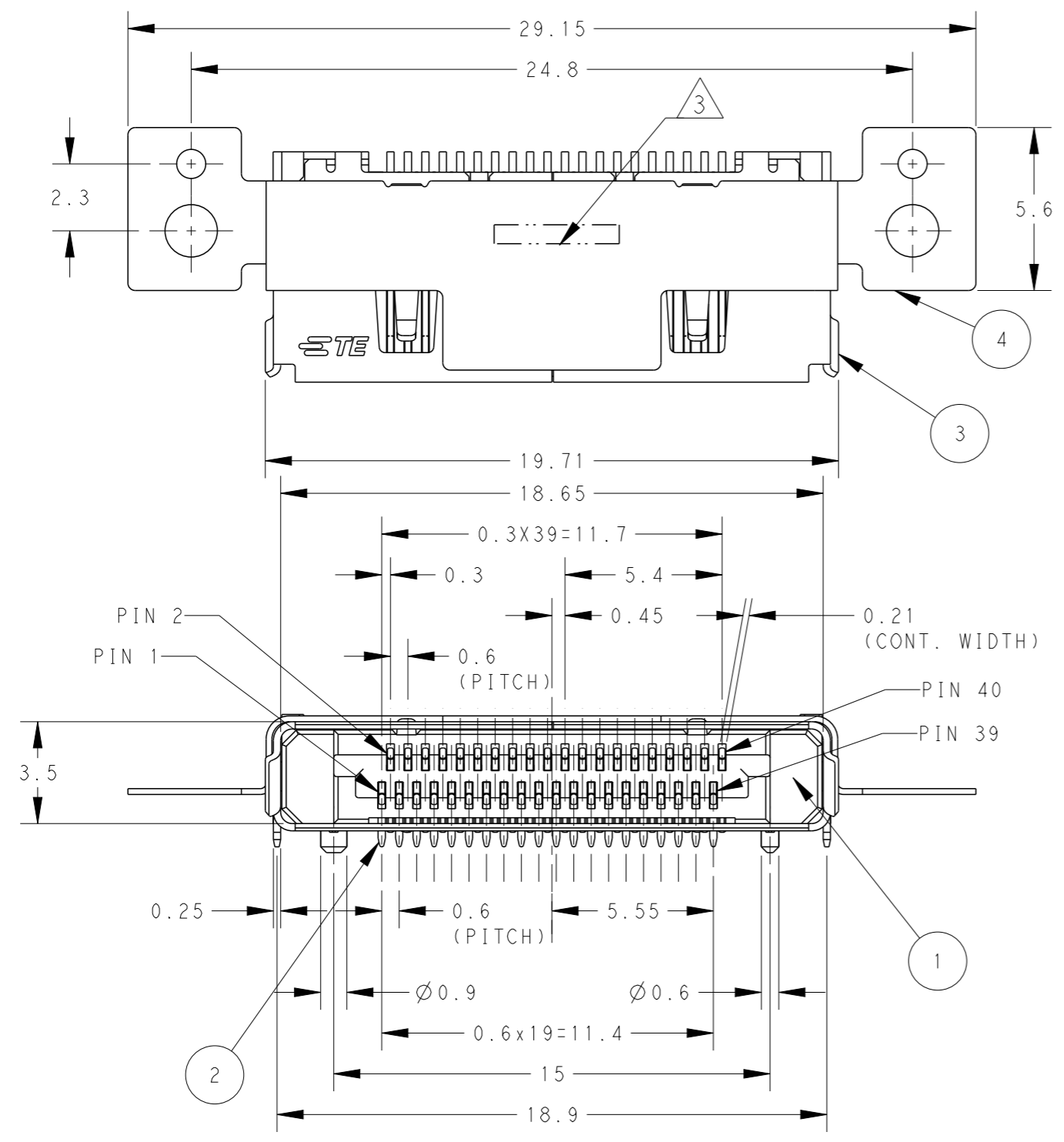

2129364-1, 1-2129364-1; AS SHOWN

- ① MATERIAL:  
 HOUSING: THERMO-PLASTIC (UL94V-0, BLACK).  
 CONTACT: COPPER ALLOY.  
 SHELL: STAINLESS STEEL.  
 BRACKET: STAINLESS STEEL.
- ② FINISH:  
 CONTACT: ALL OVER 2um MIN. Ni UNDER PLATING.  
 0.254um MIN. Au PLATING ON CONTACT AREA.  
 1~3um Tin PLATING ON TINE AREA.  
 SHELL: ALL OVER 1.3um MIN. Ni UNDER PLATING (FOR 2129364-1, -2).  
 ALL OVER 0.5um MIN. BLACK-Ni UNDER PLATING (FOR 1-2129364-1).
- ③ DATE CODE

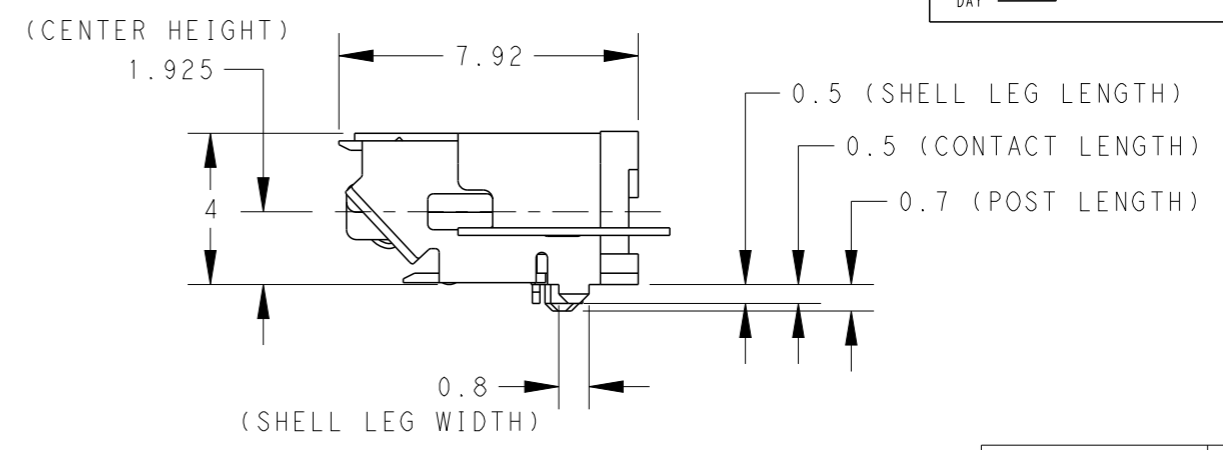
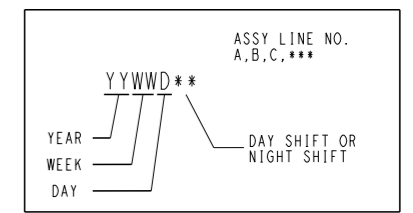

WITH BRACKET

BLACK-Ni	1-2129364-1
Ni	2129364-1
FINISH	PART NUMBER
1	BRACKET ④
1	SHELL ③
40	CONTACT ②
1	HOUSING ①
Q'TY	NAME ITEM

VIEW A

THIS DRAWING IS A CONTROLLED DOCUMENT.		DWN T. KUO 25NOV2011	TE Connectivity RECEPTACLE ASSY, 0.6mm PITCH CHAMP DOCKING CONNECTOR, 40POS			
DIMENSIONS: mm		CHK V. PENG 25NOV2011				
TOLERANCES UNLESS OTHERWISE SPECIFIED:		APVD H. KODAMA 25NOV2011				
0 PLC ± 1 PLC ±0.25 2 PLC ±3° 3 PLC ± 4 PLC ± ANGLES ±		PRODUCT SPEC 108-99033				
MATERIAL ①	FINISH ②	APPLICATION SPEC -	SIZE A3	CAGE CODE 00779	DRAWING NO C-2129364	RESTRICTED TO -
CUSTOMER DRAWING			SCALE 5:1	SHEET 1	OF 6	REV A1

LOC  
DW

DIST

REVISIONS

P	LTR	DESCRIPTION	DATE	DWN	APVD
-	-	SEE SHEET 1	-	-	-

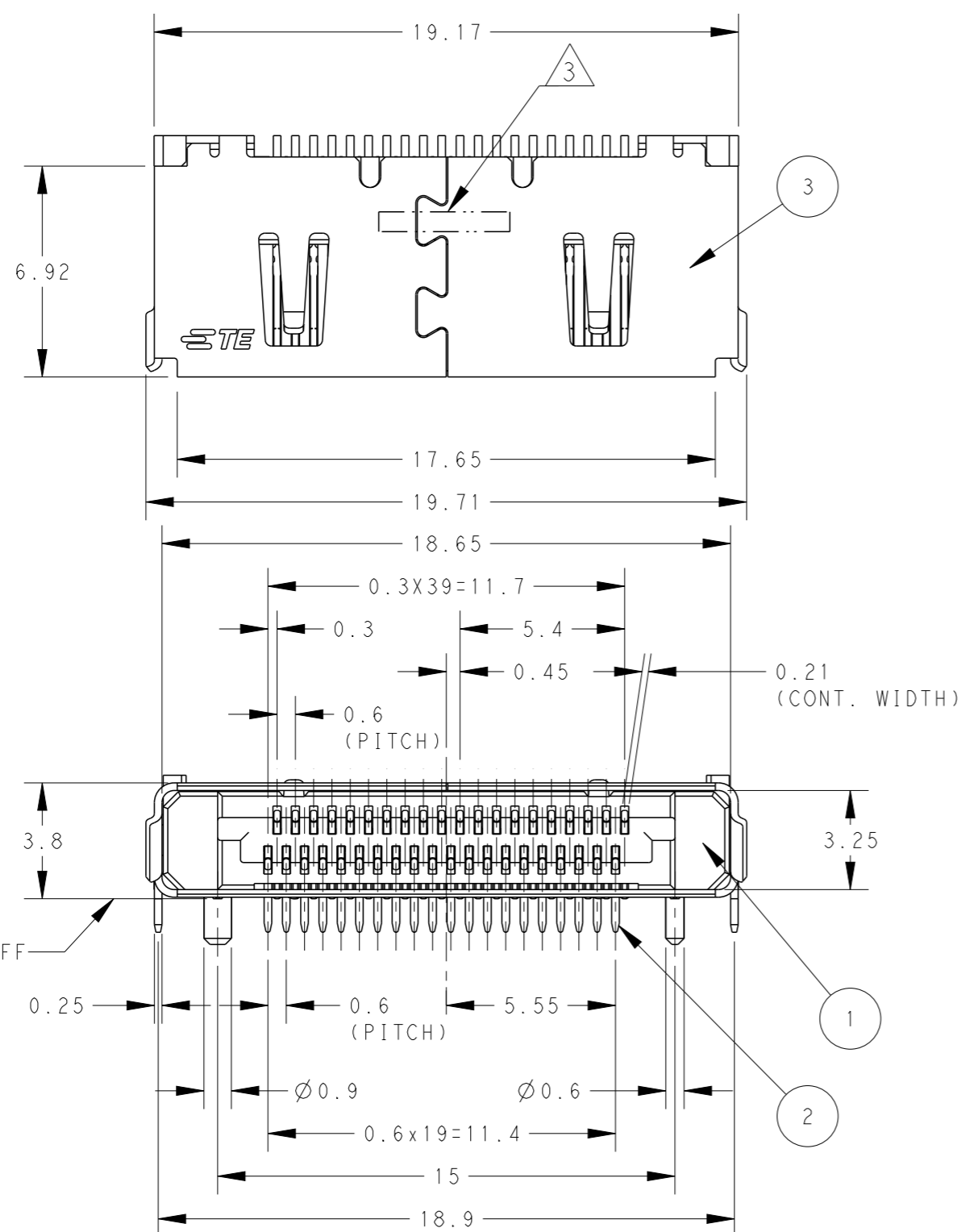

2129364-2; AS SHOWN

WITHOUT BRACKET

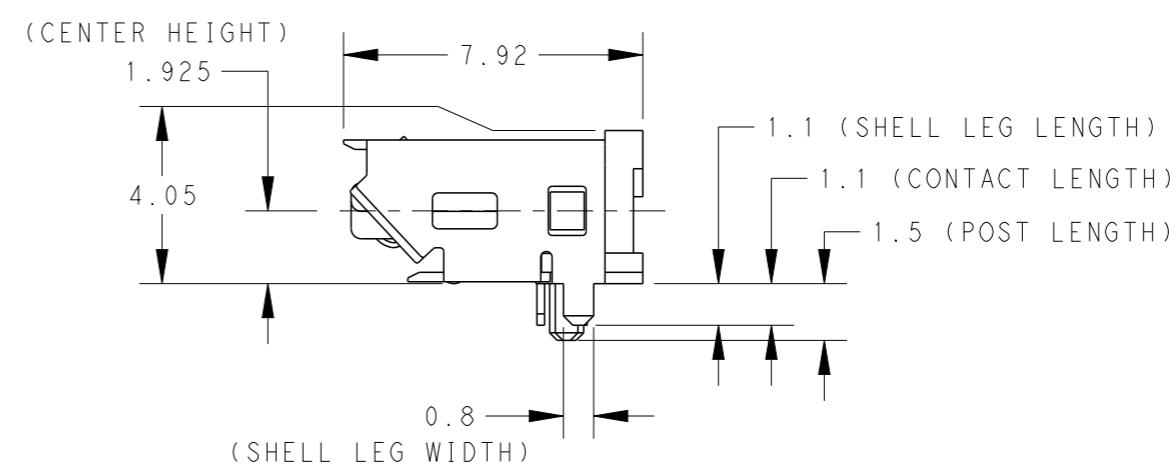

Q'TY	NAME	ITEM
1	SHELL	③
40	CONTACT	②
1	HOUSING	①

THIS DRAWING IS A CONTROLLED DOCUMENT.		DWN	-	<b>STE</b> TE Connectivity																	
DIMENSIONS: mm		CHK	-																		
TOLERANCES UNLESS OTHERWISE SPECIFIED:		APVD	-																		
<table border="0"> <tr><td>0 PLC</td><td>±</td><td>±0.25</td></tr> <tr><td>1 PLC</td><td>±</td><td>±0.25</td></tr> <tr><td>2 PLC</td><td>±</td><td>±3°</td></tr> <tr><td>3 PLC</td><td>±</td><td>±3°</td></tr> <tr><td>4 PLC</td><td>±</td><td>±</td></tr> <tr><td>ANGLES</td><td>±</td><td>±</td></tr> </table>		0 PLC	±		±0.25	1 PLC	±	±0.25	2 PLC	±	±3°	3 PLC	±	±3°	4 PLC	±	±	ANGLES	±	±	PRODUCT SPEC
0 PLC	±	±0.25																			
1 PLC	±	±0.25																			
2 PLC	±	±3°																			
3 PLC	±	±3°																			
4 PLC	±	±																			
ANGLES	±	±																			
MATERIAL		APPLICATION SPEC	-	NAME RECEPTACLE ASSY, 0.6mm PITCH CHAMP DOCKING CONNECTOR, 40POS																	
FINISH		WEIGHT	0.83g	SIZE A3																	
CUSTOMER DRAWING		CAGE CODE 00779		DRAWING NO 2129364																	
		SCALE 5:1		RESTRICTED TO -																	
		SHEET 2 OF 6		REV A1																	

LOC DW DIST

REVISIONS

P	LTR	DESCRIPTION	DATE	DWN	APVD
-	-	SEE SHEET 1	-	-	-

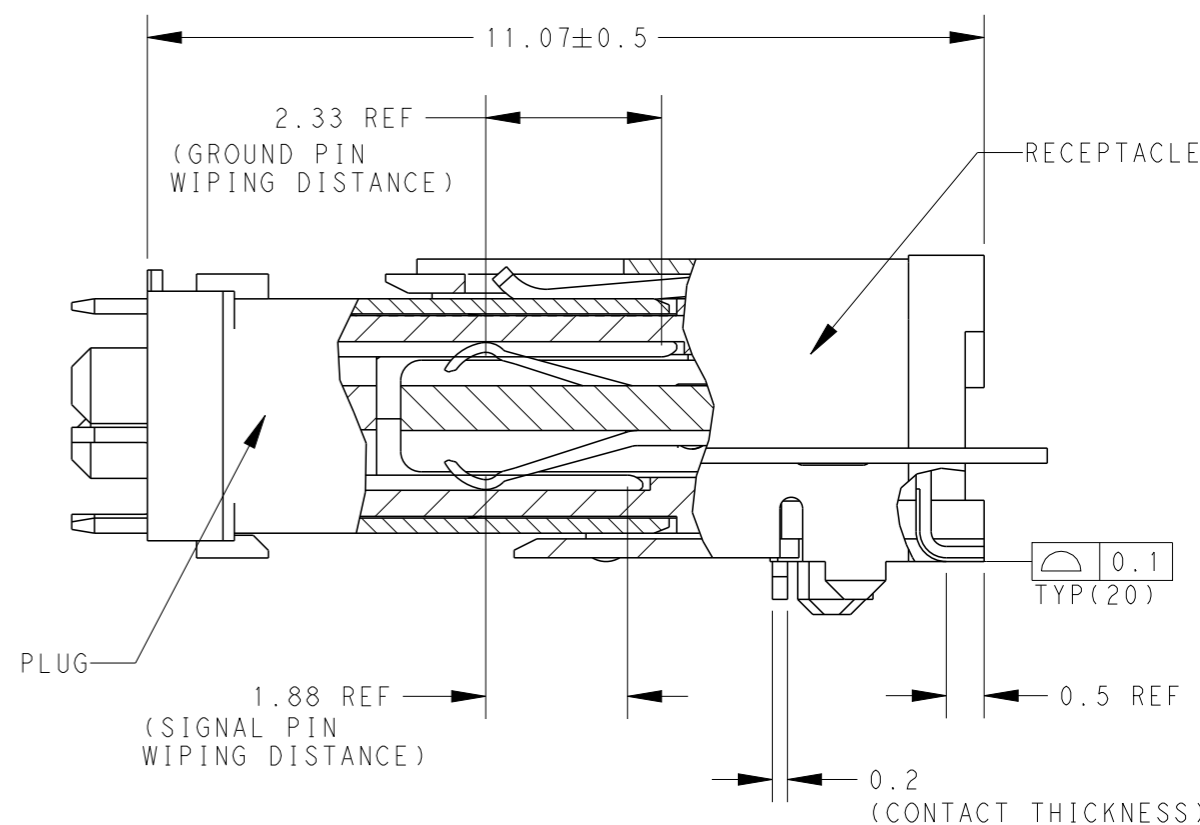
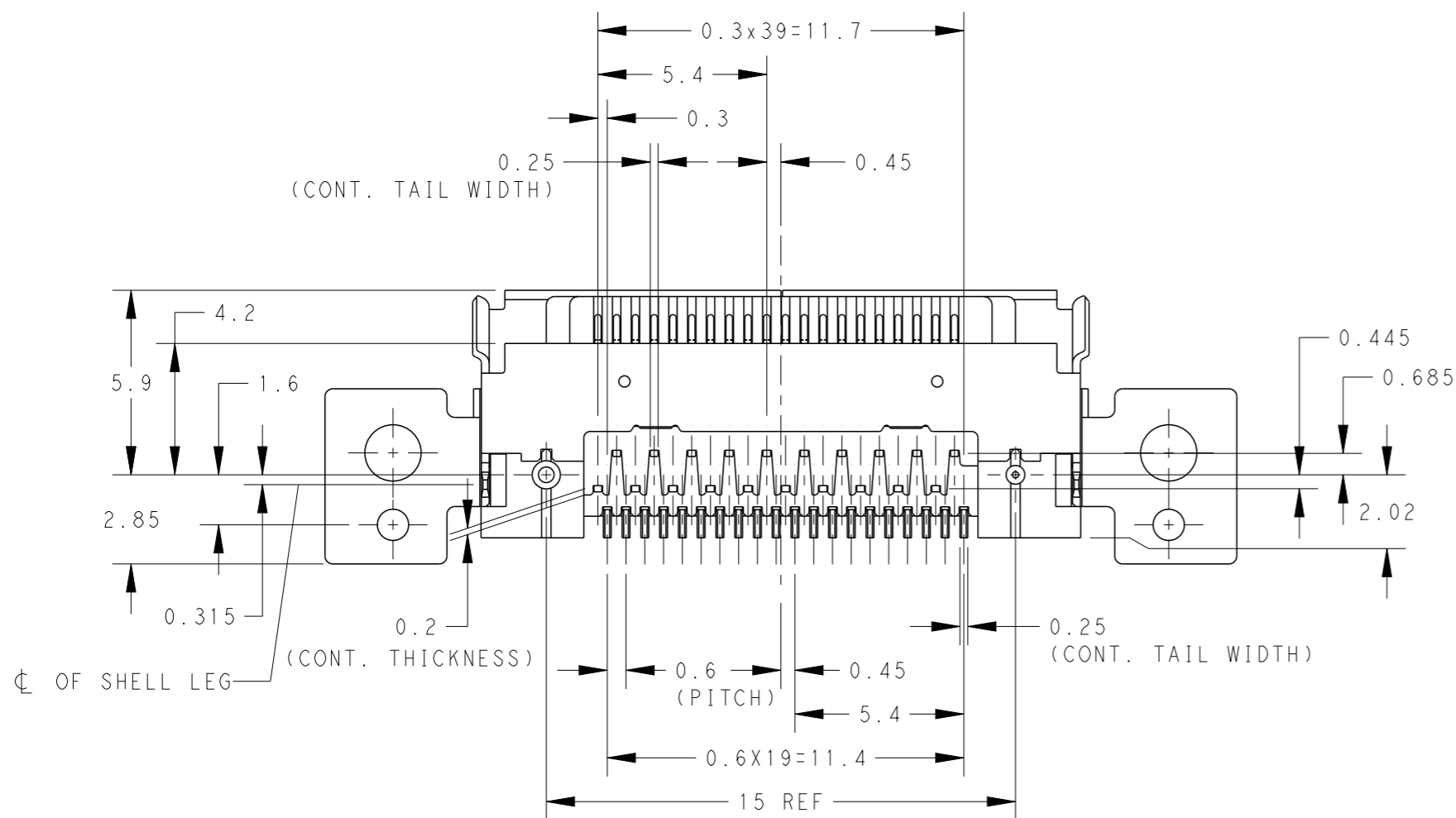

MATING CONDITION

SCALE 10:1

VIEW A  
2129364-2 IS SAME AS 2129364-1

THIS DRAWING IS A CONTROLLED DOCUMENT.

DIMENSIONS:  
mm

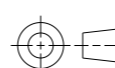

TOLERANCES UNLESS OTHERWISE SPECIFIED:

0 PLC	±	±0.25
1 PLC	±	±0.25
2 PLC	±	±3°
3 PLC	±	±
4 PLC	±	±
ANGLES	±	±
FINISH	-	-

MATERIAL

DWN	-
CHK	-
APVD	-
PRODUCT SPEC	-
APPLICATION SPEC	-
WEIGHT	-



TE Connectivity

NAME  
RECEPTACLE ASSY, 0.6mm PITCH  
CHAMP DOCKING CONNECTOR, 40POS

SIZE A3 CAGE CODE 00779 DRAWING NO C-2129364

RESTRICTED TO

CUSTOMER DRAWING

SCALE 5:1

SHEET 3 OF 6

REV A1



THIS DRAWING IS UNPUBLISHED. RELEASED FOR PUBLICATION 20  
 © COPYRIGHT 20 BY - ALL RIGHTS RESERVED.

LOC DW  
 DIST

REVISIONS					
P	LTR	DESCRIPTION	DATE	DWN	APVD
-	-	SEE SHEET 1	-	-	-

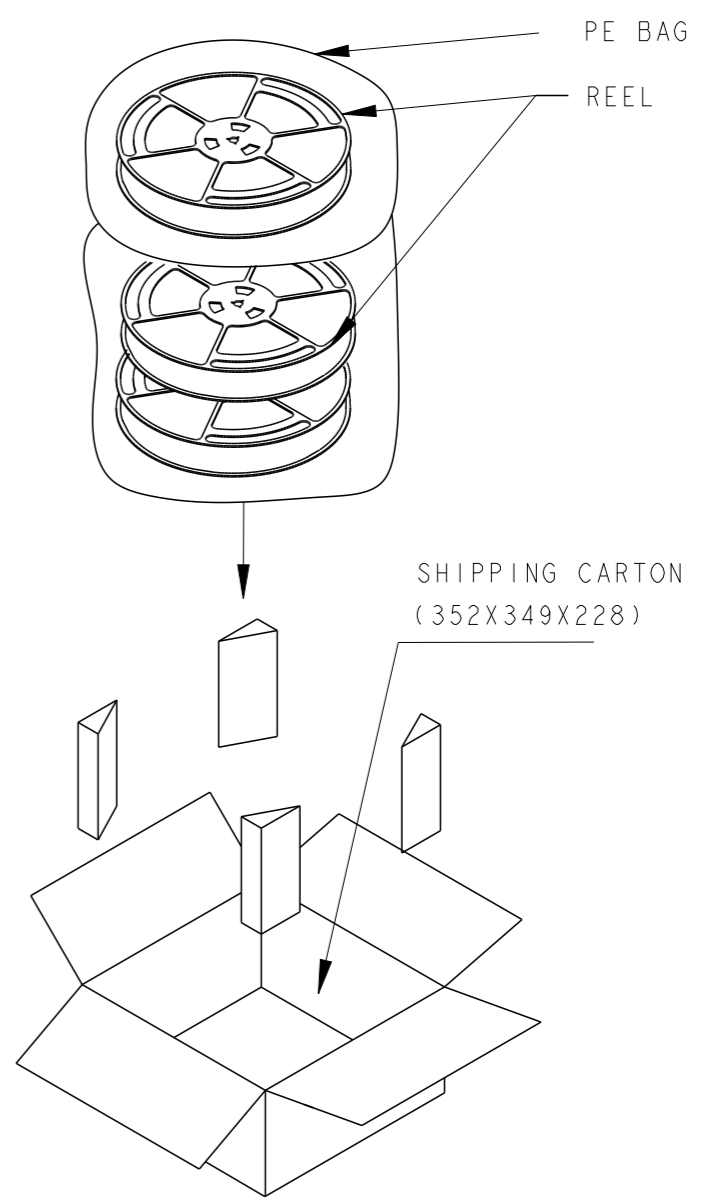
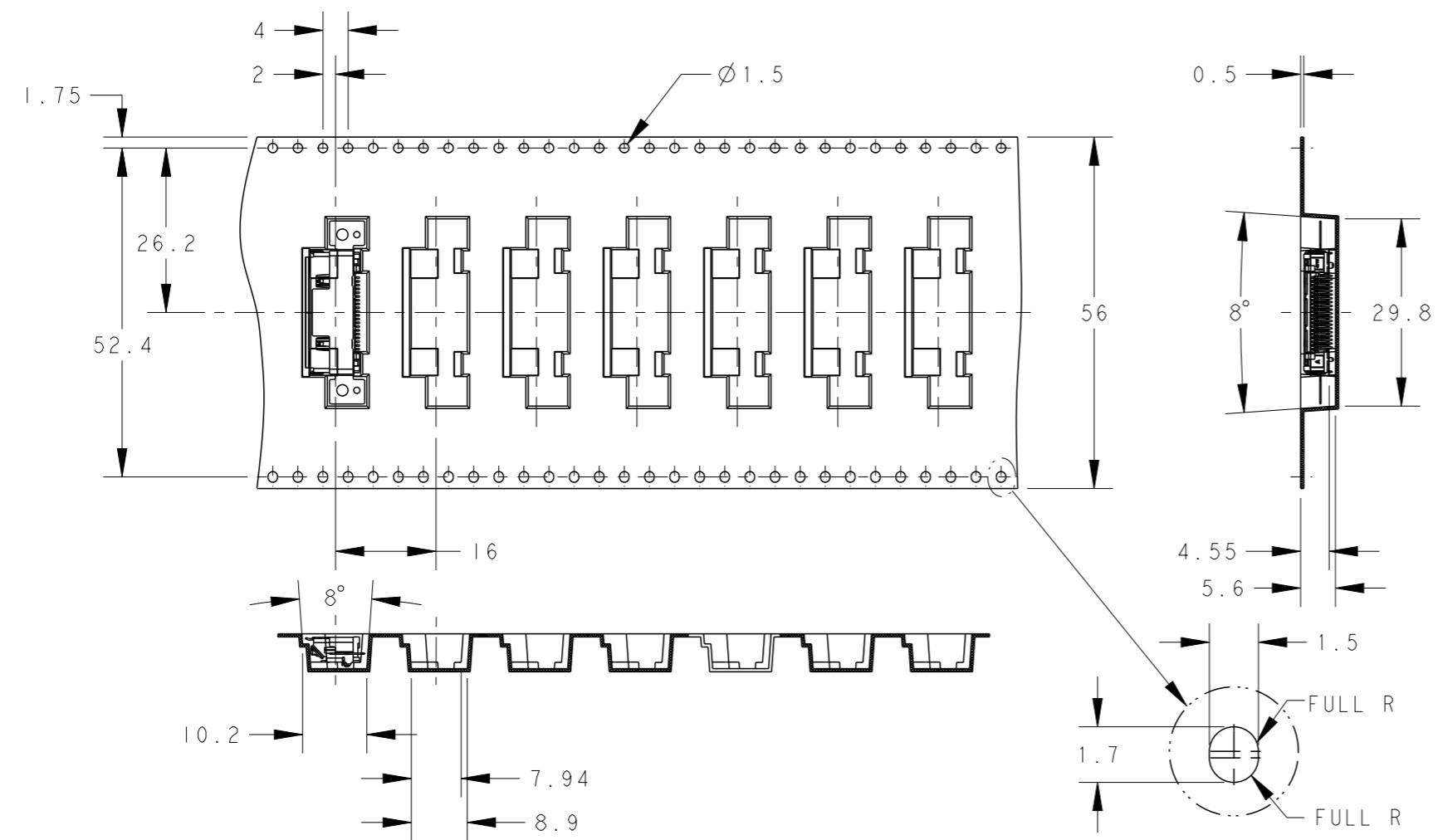

6. PACKING MATERIAL:  
 CARRY TAPE: PS; COLOR: BLACK.  
 COVER TAPE: PET; COLOR: CLEAR.  
 PEELING STRENGTH OF COVER TAPE: 0.2N~1.2N

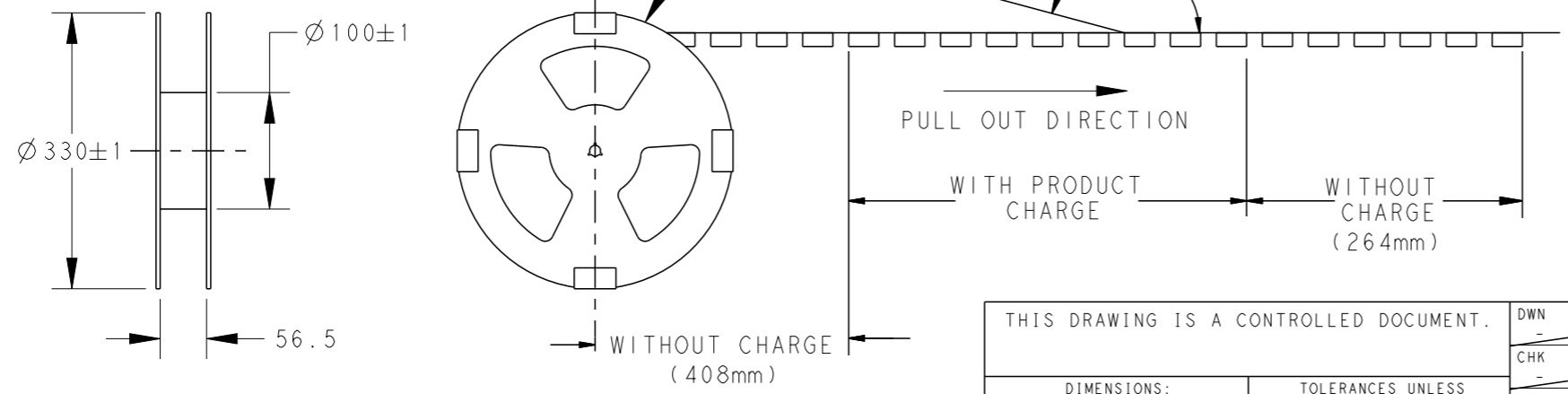
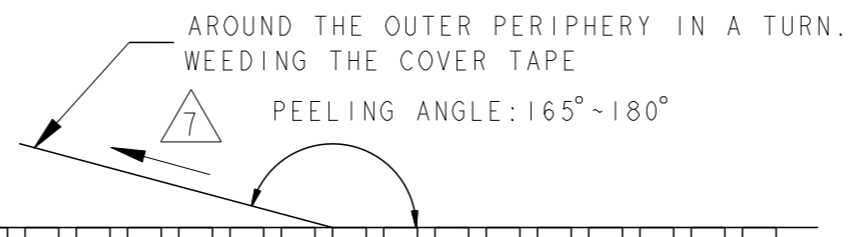

1-2129364-1	600	3	1800
2129364-1	600	3	1800
P/N	PCS/TAPE	REELS/CARTON	TOTAL QUANTITY

THIS DRAWING IS A CONTROLLED DOCUMENT.

DWN	-
CHK	-
APVD	-
PRODUCT SPEC	-
APPLICATION SPEC	-
WEIGHT	-

**STE** TE Connectivity

NAME: RECEPTACLE ASSY, 0.6mm PITCH CHAMP DOCKING CONNECTOR, 40POS

SIZE	CAGE CODE	DRAWING NO	RESTRICTED TO
A3	00779	C-2129364	-

CUSTOMER DRAWING SCALE: FREE SHEET 5 OF 6 REV A1

THIS DRAWING IS UNPUBLISHED. RELEASED FOR PUBLICATION 20  
 © COPYRIGHT 20 BY - ALL RIGHTS RESERVED.

LOC		DIST		REVISIONS				
P	LTR	DESCRIPTION	DATE	DWN	APVD			
		SEE SHEET 1	-	-	-			

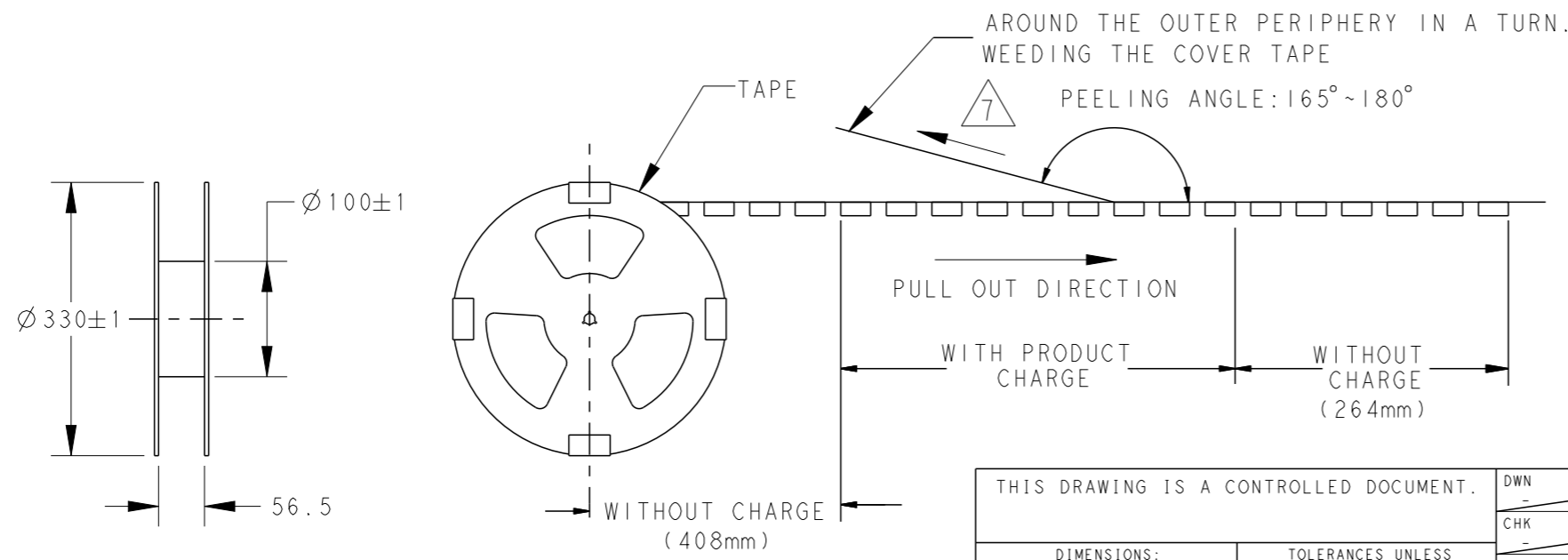
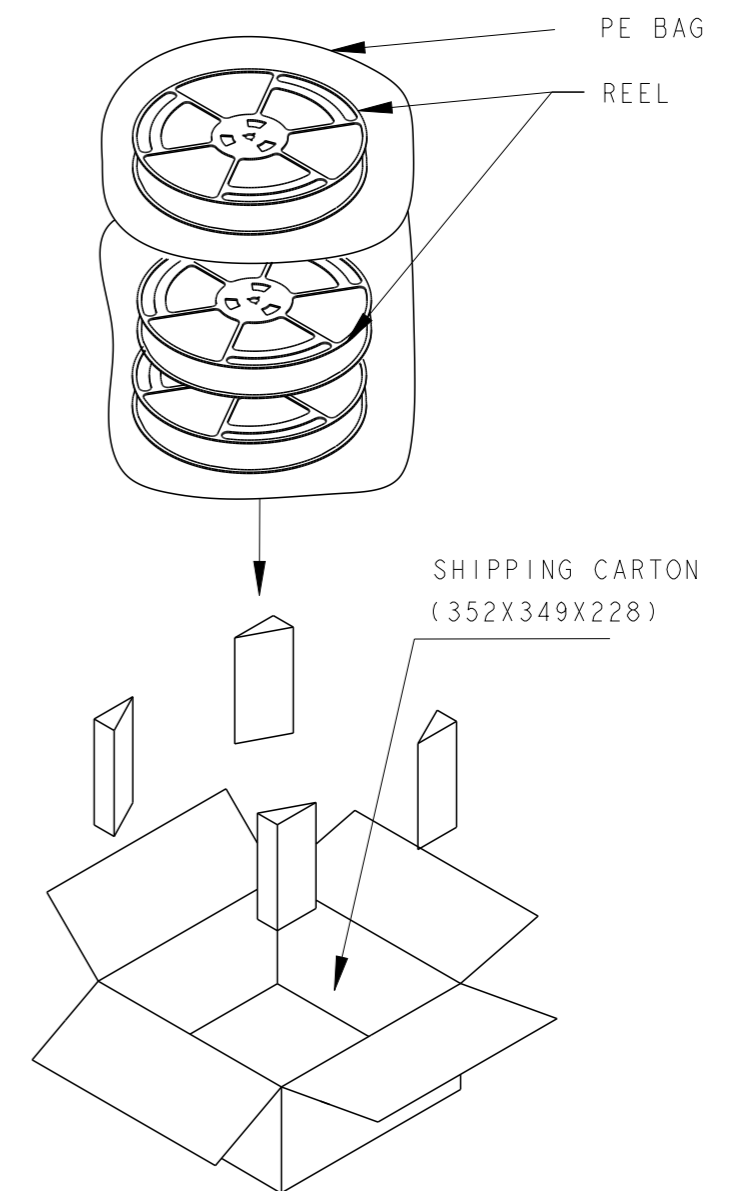
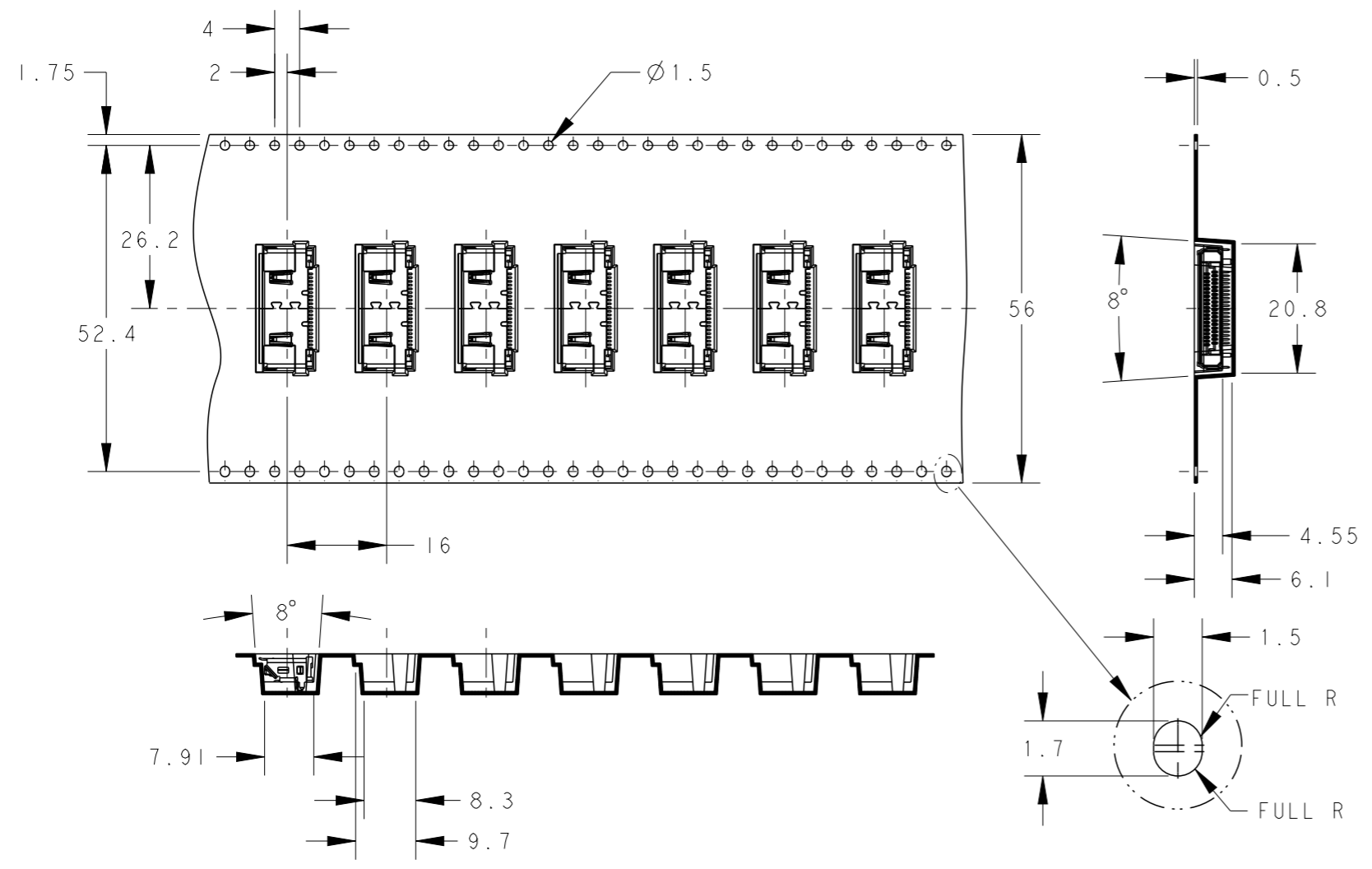

2129364-2	600	3	1800
P/N	PCS/TAPE	REELS/CARTON	TOTAL QUANTITY

THIS DRAWING IS A CONTROLLED DOCUMENT.

DIMENSIONS: mm	TOLERANCES UNLESS OTHERWISE SPECIFIED:	DWN	-
0 PLC	±	CHK	-
1 PLC	±	APVD	-
2 PLC	± ±0.5	PRODUCT SPEC	-
3 PLC	± ±3°	APPLICATION SPEC	-
4 PLC	±	WEIGHT	-
ANGLES	±	<p><b>STE</b> TE Connectivity</p> <p>NAME: RECEPTACLE ASSY, 0.6mm PITCH CHAMP DOCKING CONNECTOR, 40POS</p>	
FINISH	-	SIZE	A3
MATERIAL	-	CAGE CODE	00779
		DRAWING NO	C-2129364
		RESTRICTED TO	-

CUSTOMER DRAWING SCALE: FREE SHEET 6 OF 6 REV A1