

NOTES:  
 1. MATERIAL:  
 OVER MOLD - POLYBUTYLENE TEREPHTHALATE (PBT), 94-V0, GLASS FILLED 30%.  
 LATCH - STAINLESS STEEL ALLOY.  
 CABLE -  
 SIGNALS PVC INSULATION  
 SOLID COPPER SIGNAL AND DRAIN.  
 INNER DIELECTRIC IS POLYOLEFIN  
 TWIN-AX SHIELD IS ALUMINIZED POLYESTER FOIL.  
 PCB - FR4

- PRODUCT TO PERFORM PER PRODUCT SPECIFICATION: PS-79536-001.
- PRODUCT SERIES 79536 MATES TO 75783 (RIGHT ANGLE), 75794 (VERTICAL) AND 47077 SERIES MATES TO 87861 SERIES.
- THIS PRODUCT CONFORMS TO THE MECHANICAL DIMENSIONING AND ELECTRICAL PERFORMANCE REQUIREMENTS OF SFF-8086, SFF-8087 AND SFF-8484 (SAS).
- MINIMUM RECOMMENDED RADIUS IS 28 MM.
- PRODUCT IS RoHS COMPLIANT.
- LABLE INFO.  
 MOLEX  
 <<PART NUMBER>>  
 MADE IN CHINA  
 WW/YY

MATERIAL	SIDEBANDS	APPLICATION	SLEEVING	AWG	LENGTH (M)	TOL (+/-)	PIN OUT
74562-5000	YES	IPASS on BP	YES	30	0.152	0.015	PIN OUT 1
74562-5001	YES	IPASS on BP	YES	30	0.3	0.015	PIN OUT 1
74562-5002	YES	IPASS on BP	YES	30	0.5	0.015	PIN OUT 1
74562-5003	YES	IPASS on BP	YES	30	0.6	0.015	PIN OUT 1
74562-5004	YES	IPASS on BP	YES	28	1	0.030	PIN OUT 1
74562-5100	NO	IPASS on BP	YES	30	0.152	0.015	PIN OUT 2
74562-5101	NO	IPASS on BP	YES	30	0.3	0.015	PIN OUT 2
74562-5102	NO	IPASS on BP	YES	30	0.5	0.015	PIN OUT 2
74562-5103	NO	IPASS on BP	YES	30	0.6	0.015	PIN OUT 2
74562-5104	NO	IPASS on BP	YES	28	1	0.030	PIN OUT 2

IPASS™ IS A TRADEMARK OF MOLEX.

<b>ENTER DESCRIPTION</b> EC NO: USY2006-0249 DR: K.PHILLIPS 2006/02/01 CHKD: T.HALL 2006/02/01 APPR: DDOYE 2006/02/07	<b>QUALITY SYMBOLS</b> ▽=0 ▽=0	<b>GENERAL TOLERANCES (UNLESS SPECIFIED)</b>		<b>DIMENSION STYLE</b> MM ONLY		SCALE 1:1	DESIGN UNITS METRIC	THIRD ANGLE PROJECTION			
		4 PLACES ± --- ± ---	3 PLACES ± --- ± .01	2 PLACES ± 0.25 ± ---	1 PLACE ± --- ± ---	DRAWN BY K.PHILLIPS	DATE 2005/08/18	TITLE IPASS(MINI-SAS)INTERNAL CABLE ASSY. 36 CKT TO 8484 RT ANGLE			
		ANGULAR ± 1 °				CHECKED BY T.HALL	DATE 2005/08/18	MOLEX MOLEX INCORPORATED			
		DRAFT WHERE APPLICABLE MUST REMAIN WITHIN DIMENSIONS				APPROVED BY D.DOYE	DATE 2005/08/18	MATERIAL NO. SEE CHART	DOCUMENT NO. SD-74562-500	SHEET NO. 1 OF 2	

CHART CONFORMS TO SAS 1.1 09D SECTION 5.2.4.12.4 AND SECTION 5.2.3.2.3.3 TBL 26 / 5.2.3.2.2.3 TBL 24

CHART CONFORMS TO SAS 1.1 09D SECTION 5.2.4.12.4 AND SECTION 5.2.3.3.3 TBL 27 / 5.2.2.2.2.3 TBL 25

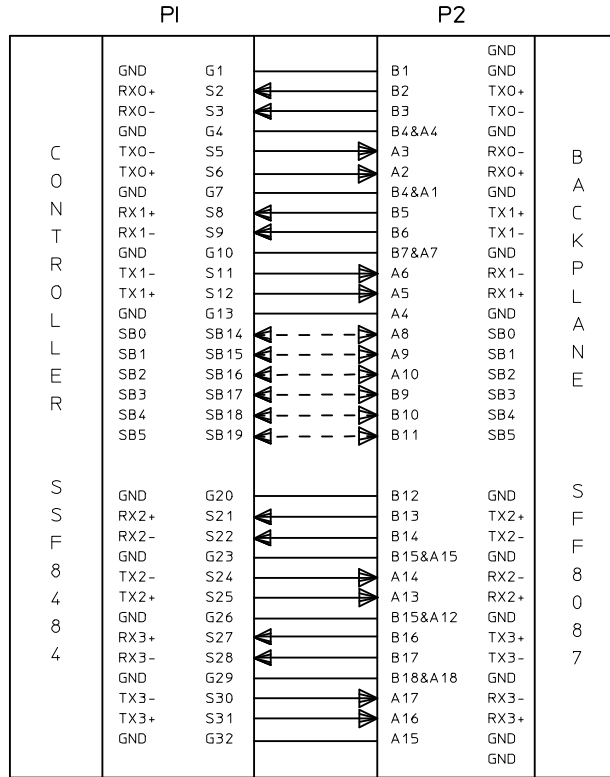

PINOUT 1

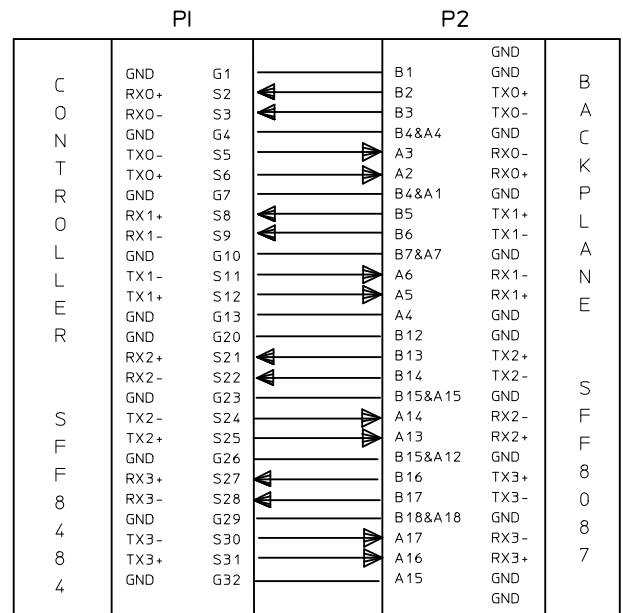

PINOUT 2

IPASS™ IS A TRADEMARK OF MOLEX.

<b>ENTER DESCRIPTION</b> EC NO: USY2006-0249 DRAWN: KPHILLIPS 2006/02/01 CHKD: T.HALL 2006/02/01 APPR: DDOYE 2006/02/07	<b>QUALITY SYMBOLS</b> ▽=0 ▽=0	<b>GENERAL TOLERANCES (UNLESS SPECIFIED)</b>		<b>DIMENSION STYLE</b> MM ONLY	<b>SCALE</b> 1:1	<b>DESIGN UNITS</b> METRIC	THIRD ANGLE PROJECTION	
		4 PLACES ± --- ± ---	mm INCH	DRAWN BY DATE K.PHILLIPS 2005/08/18	TITLE IPASS(MINI-SAS)INTERNAL CABLE ASSY. 36 CKT TO 8484 RT ANGLE			
		3 PLACES ± --- ± .01		CHECKED BY DATE T.HALL 2005/08/18	MOLEX MOLEX INCORPORATED			
		2 PLACES ± 0.25 ± --- 1 PLACE ± --- ± --- ANGULAR ± 1 °		APPROVED BY DATE D.DOYE 2005/08/18	MATERIAL NO. SEE CHART	DOCUMENT NO. SD-74562-500	SHEET NO. 2 OF 2	
DRAFT WHERE APPLICABLE MUST REMAIN WITHIN DIMENSIONS			SIZE B	THIS DRAWING CONTAINS INFORMATION THAT IS PROPRIETARY TO MOLEX INCORPORATED AND SHOULD NOT BE USED WITHOUT WRITTEN PERMISSION				

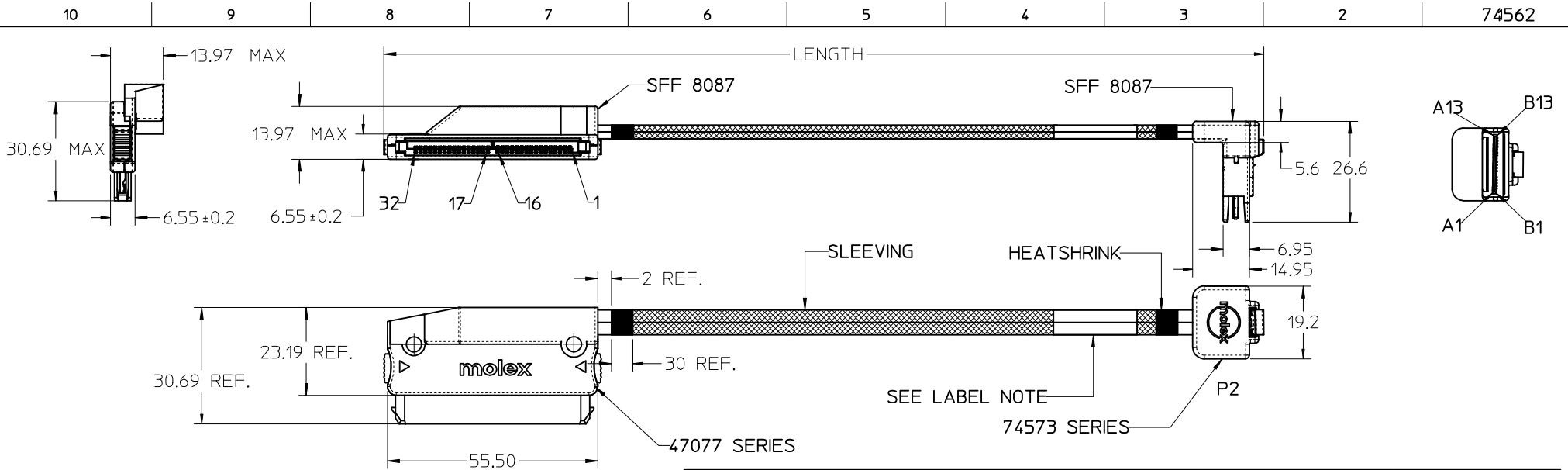

NOTES:

- MATERIAL:
  - OVER MOLD - POLYBUTYLENE TEREPHTHALATE (PBT), 94-V0, GLASS FILLED 30%.
  - LATCH - STAINLESS STEEL ALLOY.
  - CABLE -
    - SIGNALS PVC INSULATION
    - SOLID COPPER SIGNAL AND DRAIN.
    - INNER DIELECTRIC IS POLYOLEFIN
    - TWIN-AX SHIELD IS ALUMINIZED POLYESTER FOIL.
  - PCB - FR4

- PRODUCT TO PERFORM PER PRODUCT SPECIFICATION: PS-79536-001.
- PRODUCT SERIES 79536 MATES TO 75783 (RIGHT ANGLE), 75794 (VERTICAL) AND 47077 SERIES MATES TO 87861 SERIES.
- THIS PRODUCT CONFORMS TO THE MECHANICAL DIMENSIONING AND ELECTRICAL PERFORMANCE REQUIREMENTS OF SFF-8086, SFF-8087 AND SFF-8484 (SAS).
- MINIMUM RECOMMENDED RADIUS IS 28 MM.
- PRODUCT IS ROHS COMPLIANT.
- LABEL INFO:
  - MOLEX
  - <<PART NUMBER>>
  - MADE IN CHINA
  - WW/YY

MATERIAL	SIDE BANDS	APPLICATION	SLEEVING	AWG	LENGTH (M)	TOL (+/-)
74562-5501	YES	IPASS on BP	YES	30	0.533	0.5
74562-5502	YES	IPASS on BP	YES	30	0.457	0.5

IPASS™ IS A TRADEMARK OF MOLEX.

INITIAL RELEASE EC NO: USY2007-0456 DRAWN BY: CCX CHKD: 2007/06/01 APPR: DDOYE 2007/06/13	QUALITY SYMBOLS ▽=0 ▽=0	GENERAL TOLERANCES (UNLESS SPECIFIED)		DIMENSION STYLE <b>MM ONLY</b>	SCALE <b>1:1</b>	DESIGN UNITS <b>METRIC</b>	THIRD ANGLE PROJECTION		
		4 PLACES ± --- ± ---	3 PLACES ± --- ± .01	2 PLACES ± 0.25 ± ---	1 PLACE ± --- ± ---	DRAWN BY: CCX DATE: 2007/05/23	TITLE <b>36 CKT RT ANG DWN TO 8484 RT ANG CABLE ASSEMBLY</b>		
		ANGULAR ± 1°				CHECKED BY: _____ DATE: _____	MOLEX MOLEX INCORPORATED		
		DRAFT WHERE APPLICABLE MUST REMAIN WITHIN DIMENSIONS				APPROVED BY: _____ DATE: _____	MATERIAL NO. <b>SEE CHART</b>	DOCUMENT NO. <b>SD-74562-550</b>	SHEET NO. <b>1 OF 2</b>
THIS DRAWING CONTAINS INFORMATION THAT IS PROPRIETARY TO MOLEX INCORPORATED AND SHOULD NOT BE USED WITHOUT WRITTEN PERMISSION									

CHART CONFORMS TO SAS 1.1 09D SECTION 5.2.4.12.4  
AND SECTION 5.2.3.2.3.3 TBL 26 / 5.2.3.2.2.3 TBL 24

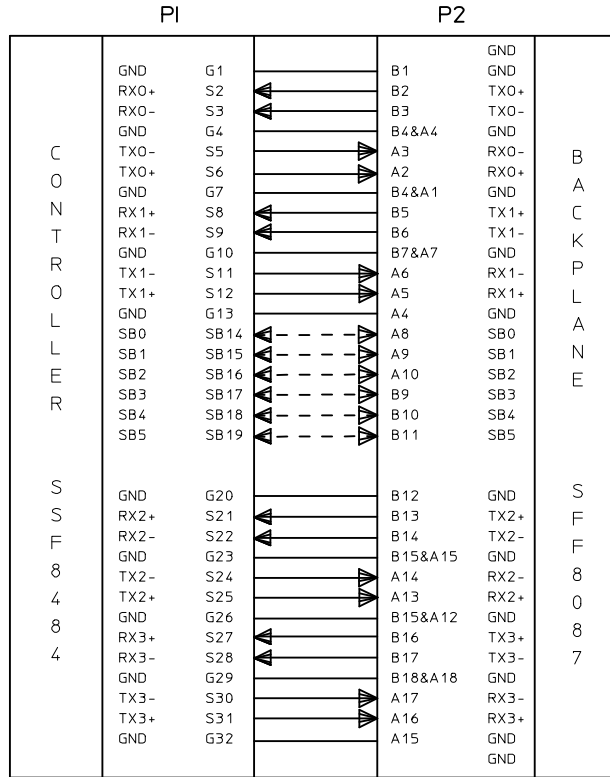

IPASS™ IS A TRADEMARK OF MOLEX.

INITIAL RELEASE EC NO: USY2007-0456 DRAWN:CCOX 2007/06/01 CHKD: 2007/06/01 APPR:DDOYE 2007/06/13 A	QUALITY SYMBOLS ▽=0 ▽=0	GENERAL TOLERANCES (UNLESS SPECIFIED)		DIMENSION STYLE <b>MM ONLY</b>	SCALE 1:1	DESIGN UNITS METRIC	THIRD ANGLE PROJECTION		
		4 PLACES ± --- ± ---	mm INCH	DRAWN BY CCOX	DATE 2007/05/23	TITLE 36 CKT RT ANG DWN TO 8484 RT ANG CABLE ASSEMBLY			
		3 PLACES ± --- ± .01	2 PLACES ± 0.25 ± ---	CHECKED BY	DATE				
		1 PLACE ± --- ± ---	ANGULAR ± 1 °	DRAFT WHERE APPLICABLE MUST REMAIN WITHIN DIMENSIONS		APPROVED BY	DATE	MOLEX MOLEX INCORPORATED	SHEET NO. 2 OF 2

MATERIAL NO. SEE CHART DOCUMENT NO. SD-74562-550

SIZE B THIS DRAWING CONTAINS INFORMATION THAT IS PROPRIETARY TO MOLEX INCORPORATED AND SHOULD NOT BE USED WITHOUT WRITTEN PERMISSION