

REVISIONS					
P	LTR	DESCRIPTION	DATE	DWN	APVD
Z4		REVISED PER ECN-22-171534	30AUG2022	RK	JO

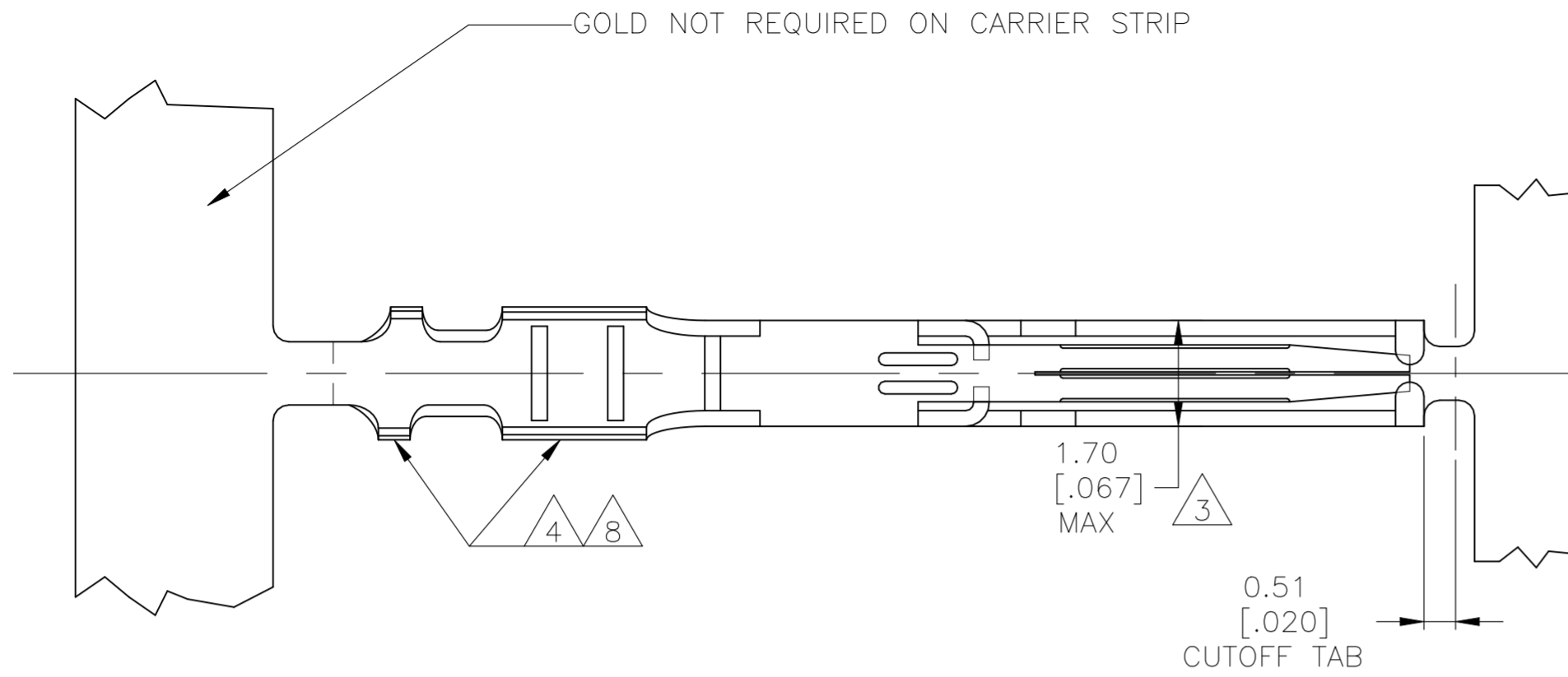

- 1 .000030 GOLD OVER .000030 NICKEL IN CONTACT AREA.
- 2 .000015 GOLD OVER .000030 NICKEL IN CONTACT AREA.
- 3 .067 MAX ALLOWED IN LOCKING POSITION AREA FOR .140 REF LENGTH.
- 4 TIN-LEAD IN CRIMP AREA.
- 5 OBSOLETE
- 6 .000050 GOLD OVER .000050 NICKEL IN CONTACT AREA. REMAINDER OF CONTACT GOLD FLASH OVER NICKEL.
- 7 .000015 GOLD OVER .000030 NICKEL IN CONTACT AREA. REMAINDER OF CONTACT GOLD FLASH OVER NICKEL.
- 8 MATTE TIN IN CRIMP AREA.
- 9 OBSOLETE PARTS: OBSOLETE CIS STREAMLINING PER D.RENAUD/D.SINISI
- 10 OBSOLETE PART

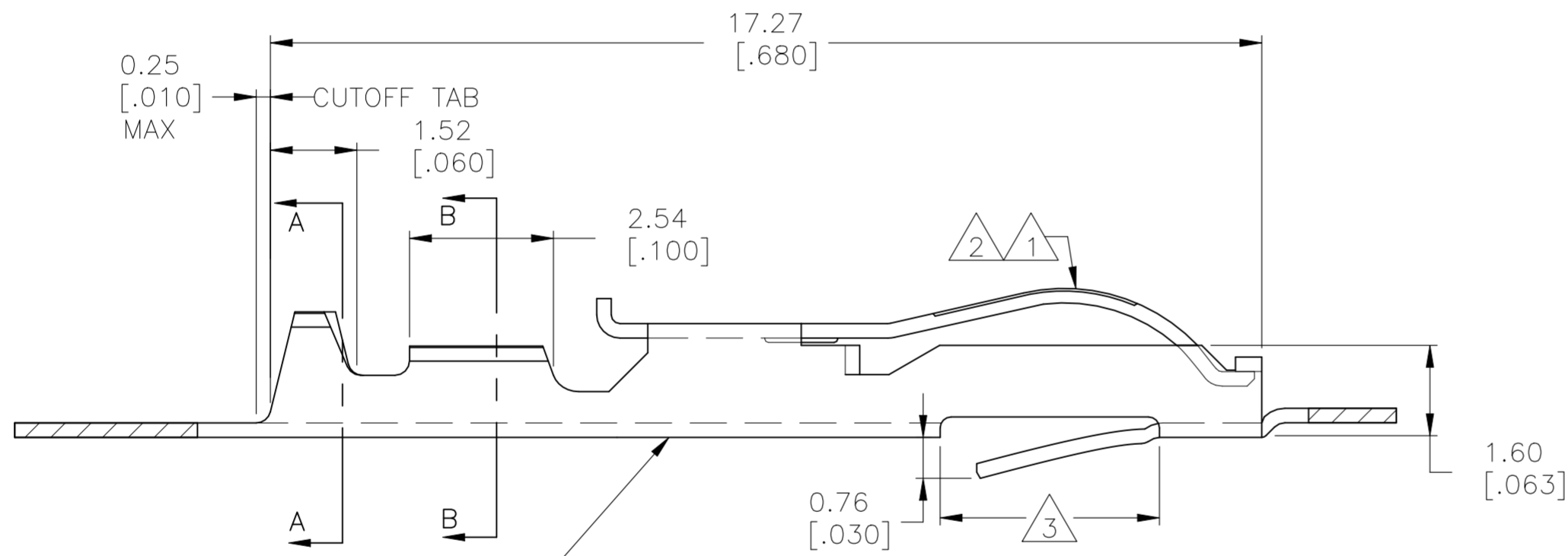

COLOUR CODED ORANGE FOR WIRE RANGE IDENTIFICATION (LOOSE PIECE ONLY)

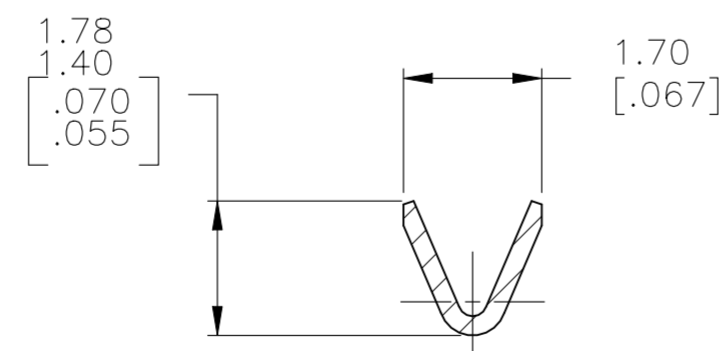
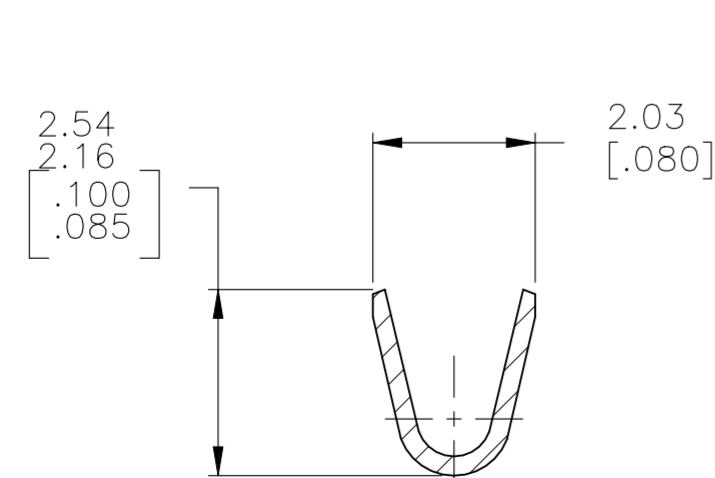
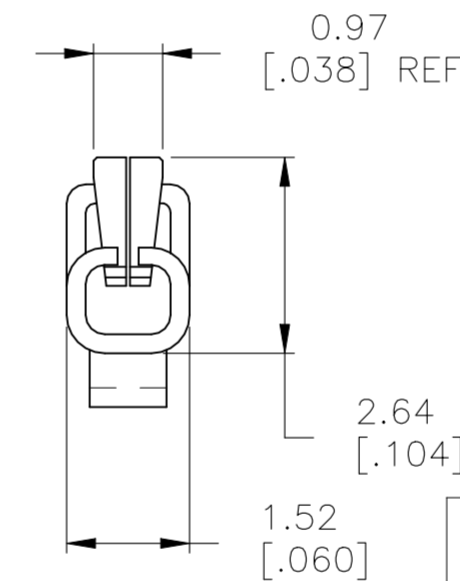

5-583616-3	9 5-583616-7	2 8	5-583616-5
5-583616-2	9 5-583616-6	1 8	5-583616-4
1-583616-0	5 1-583616-2	7	1-583616-1
583616-8	5 1-583616-3	6	9 583616-9
583616-3	5 583616-7	2 4	583616-5
10 583616-2	9 583616-6	1 4	10 583616-4
STRIP PART NO REELING LEFT TO RIGHT	STRIP PART NO REELING RIGHT TO LEFT	FINISH	LOOSE PIECE

THIS DRAWING IS A CONTROLLED DOCUMENT.		DWN A. STAUB BG 02AUG93		
DIMENSIONS: mm [INCHES]		CHK H ROSE 18FEB94		
TOLERANCES UNLESS OTHERWISE SPECIFIED:		APVD H ROSE 18FEB94	NAME CONTACT-TWIN LEAF (CRIMP-SNAP)	
0 PLC ± -		PRODUCT SPEC	SIZE A2	
1 PLC ± -		APPLICATION SPEC	CAGE CODE 00779	
2 PLC ± -		WEIGHT	DRAWING NO C=583616	
3 PLC ± -		FINISH	RESTRICTED TO	
4 PLC ± -		SEE TABLE	SCALE 10:1	
ANGLES ± -		CUSTOMER DRAWING	SHEET 1 OF 1	
MATERIAL PHOS BRONZE		REV Z4		