

Number of contacts

36-43



Mixed shells with pre-mounted signal solder cup contacts

Identification	No. of contacts ¹⁾	Part number			
		male connectors		female connectors	
		Performance level 3	S4 ²⁾	Performance level 3	S4 ²⁾
	36W4	09 69 511 7364	09 69 511 5364	09 69 501 7364	09 69 501 5364
	43W2	09 69 511 7432	09 69 511 5432	09 69 501 7432	09 69 501 5432

Male connectors

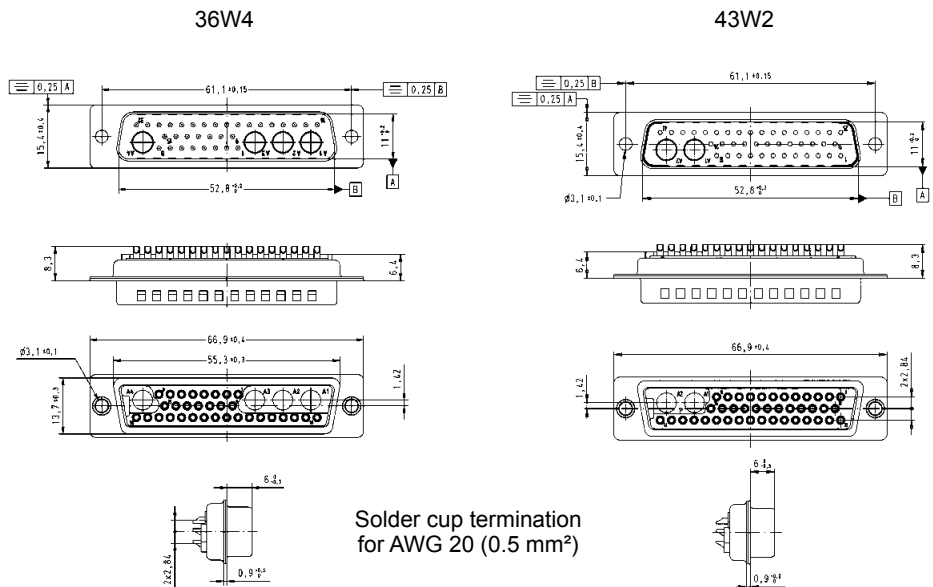

Female connectors

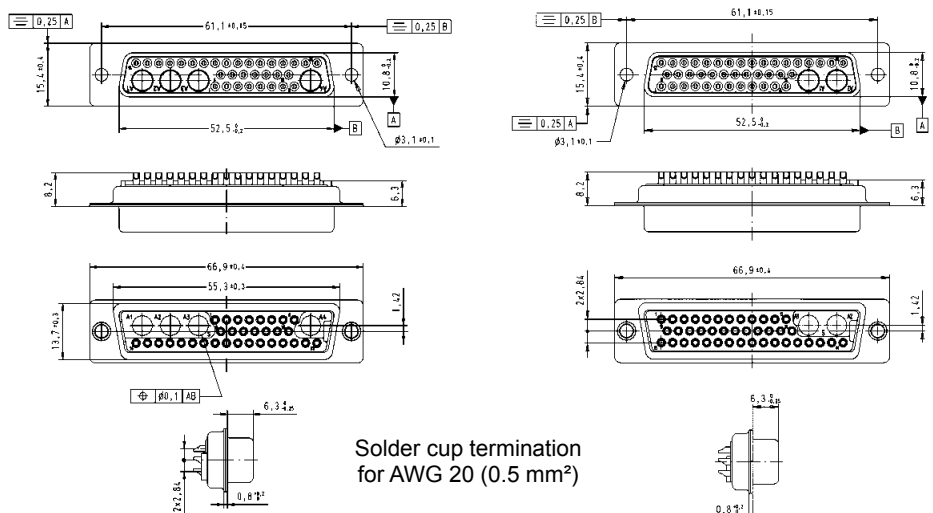

Dimensions in mm

¹⁾ Explanations see page 05.51
²⁾ S4 = 0.76 µm Au or PdNi equivalent
 Board drillings see pages 05.78 ff

Order special contacts separately. See pages 05.69 ff

D-Sub