

MATERIALS AND FINISHES

BODY BRASS
PLATED GOLD

CENTER CONTACT BERYLLIUM COPPER
PLATED GOLD

INSULATOR TEFLON

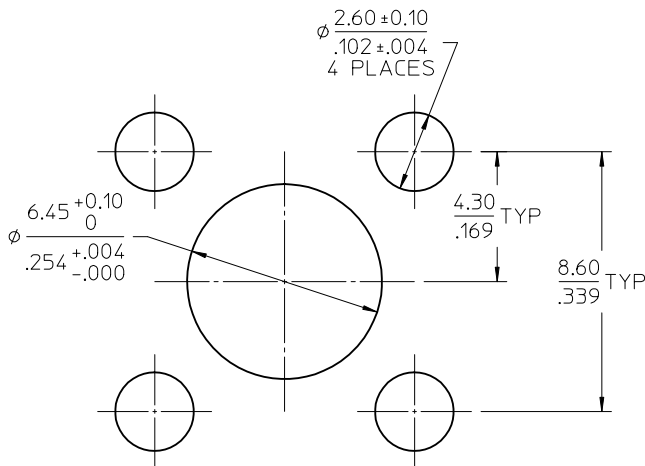
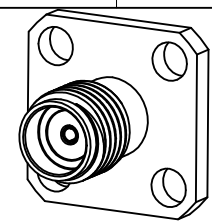

RECOMMENDED PANEL CUTOUT
MAX PANEL THICKNESS: 2.2mm (.087)

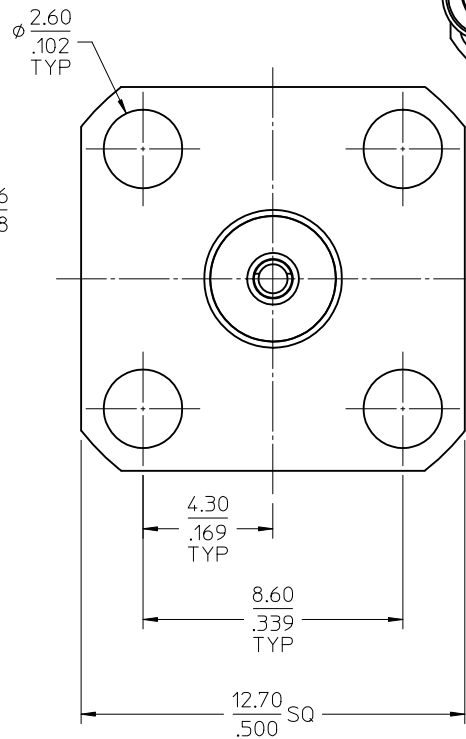
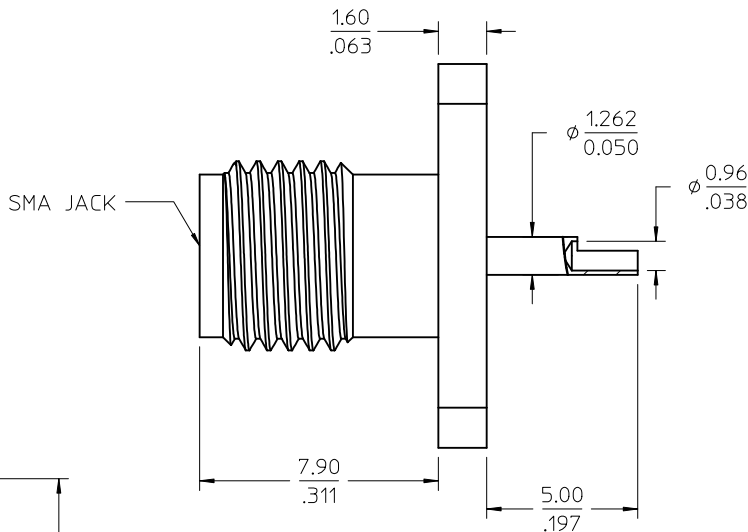

LABEL FORMAT FOR
73391-0042

PART NUMBER: 73391-0040
ORDER NUMBER: 73391-0042
MOLEX
DATE: YYWW

PS-89675-3460	ELECTRICAL/MECHANICAL
MIL-STD-348A, FIG. 310.2	INTERFACE
SPECIFICATION	DESCRIPTION

73391-0042	ONE PIECE PER BAG
73391-0041	SMALL TRAY (20 PIECES)
73391-0040	STANDARD TRAY
PART NO.	PACKAGING

CHG: UPDATE LABEL FOR -0042 EC NO: URF2012-0380 DRW: BOMALLEY 2012/01/04 CHK: AZR 2012/01/04 APPR: JWIENER 2012/01/04	QUALITY SYMBOLS ▽=0 ▽=0	DESCRIPTION REV: B3	GENERAL TOLERANCES (UNLESS SPECIFIED)	DIMENSION STYLE MM/IN	SCALE METRIC	DESIGN UNITS METRIC	THIRD ANGLE PROJECTION
			4 PLACES ± --- ± --- 3 PLACES ± --- ± --- 2 PLACES ± --- ± --- 1 PLACE ± --- ± --- ANGULAR ± 2 °	DRAWN BY DATE IRIS 1997/05/27 CHECKED BY DATE SAM 1997/05/27 APPROVED BY DATE JWIENER 2011/04/20	TITLE SMA JACK RECEPTACLE 4 HOLE FLANGE 50 OHMS SMA-JR EWR-N/A	MOLEX MOLEX INCORPORATED	
DRAFT WHERE APPLICABLE MUST REMAIN WITHIN DIMENSIONS			SEE TABLE	DOCUMENT NO. SD-73391-004	SHEET NO. 1 OF 1	THIS DRAWING CONTAINS INFORMATION THAT IS PROPRIETARY TO MOLEX INCORPORATED AND SHOULD NOT BE USED WITHOUT WRITTEN PERMISSION	