



Series 2 digital force gauges are designed for basic tension and compression force testing applications up to 500 lbF (2,500 N). Peak tension and compression readings are reliably captured via the gauges' $\pm 0.5\%$ accuracy and 500 Hz sampling rate. A backlit graphic LCD displays the current, peak tension, or peak compression reading.

The gauges are overload protected to 200% of capacity. An ergonomic, reversible aluminum housing allows for hand held use or fixture mounting, rugged enough for applications in both production and laboratory environments. Series 2 gauges are directly compatible with Mark-10 test stands and grips.



< Shown with the included cushioned shipping carton and optional accessories



> Shown with an ES20 test stand with G1061 wedge grips

Features

- Calculates peak tension and compression values
- 3 selectable units of measurement
- Ultra-compact, ergonomic housing
- Configurable default measurement unit and mode
- 500 Hz sampling rate
- Large, backlit graphic display with auto-dimming
- Powered by rechargeable battery or AC adapter
- Reversible housing for alternate load cell orientation

Display Indicators

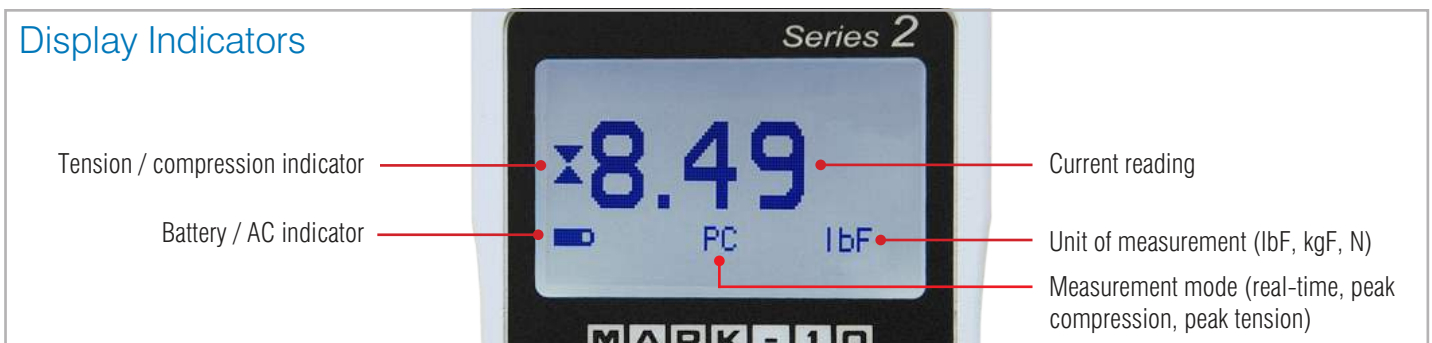

Optional Items



Carrying case

Cushioned hard plastic carrying case provides storage space for the gauge, AC adapter, and attachments.

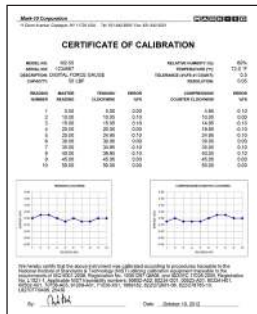

Certificate of calibration

Includes 10 data points in the tension and compression directions. NIST-traceable.



Attachments

Available individually or as kits. Select from hooks, flats, cones, chisels, v-grooves, and extension rods.

Ordering Information - Gauges

Model	Capacity x Resolution		
	lbF	kgF	N
M2-2	2 x 0.002	1 x 0.001	10 x 0.01
M2-5	5 x 0.005	2.5 x 0.002	25 x 0.02
M2-10	10 x 0.01	5 x 0.005	50 x 0.05
M2-20	20 x 0.02	10 x 0.01	100 x 0.1
M2-50	50 x 0.05	25 x 0.02	250 x 0.2
M2-100	100 x 0.1	50 x 0.05	500 x 0.5
M2-200	200 x 0.2	100 x 0.1	1000 x 1
M2-500	500 x 0.5	250 x 0.2	2500 x 2

In The Box



Series 2 force gauges are shipped as shown above, and include the following accessories:

- (1) Cushioned shipping box
- (1) AC adapter
- (1) Battery
- (1) Certificate of conformance

Ordering Information - Optional Items

For All Series 2 Gauges	
CERT	Certificate of calibration with data
12-1049	Carrying case

For M2-2 - M2-100 Gauges	
G1038	Medium hook, #10-32M (requires G1039)
G1039	Coupling, #10-32F/F
G1029	Flat head, #10-32F
G1026	Cone, #10-32F
G1025	Chisel point, #10-32F
G1027	V-groove, #10-32F
G1024	Extension rod, 5", #10-32F
23-1031-2	Attachments kit (qty. 1 of G1038 through G1024)

For M2-200 - M2-500 Gauges	
G1035	Large hook, 5/16-18M (requires G1037)
G1037	Coupling, 5/16-18F/F
G1036	Flat head, 5/16-18F
G1033	Cone, 5/16-18F
G1032	Chisel point, 5/16-18F
G1034	V-groove, 5/16-18F
G1031	Extension rod, 5", 5/16-18F
23-1031-3	Attachments kit (qty. 1 ea. of G1035 through G1031)

Specifications

Accuracy:	±0.5% of full scale
Sampling Rate:	500 Hz
Power:	AC adapter: 100-240VAC, 50-60 Hz, 0.3 A Battery: Rechargeable 8.4V NiMH Low battery indicator appears when battery level is low, and gauge powers off automatically when power reaches critical stage.
Battery life:	Backlight on: Up to 7 hours of continuous use Backlight off: Up to 24 hours of continuous use
Safe overload:	200% of full scale (display shows "OVER" at 110% and above)
Weight:	M2-2 – M2-100: 0.7 lb [0.33 kg] M2-200 – M2-500: 0.9 lb [0.41 kg]
Environmental requirements:	40 - 100°F, max. 96% humidity, non-condensing
Warranty:	3 years (see individual statement for further details)

Dimensions in [mm]

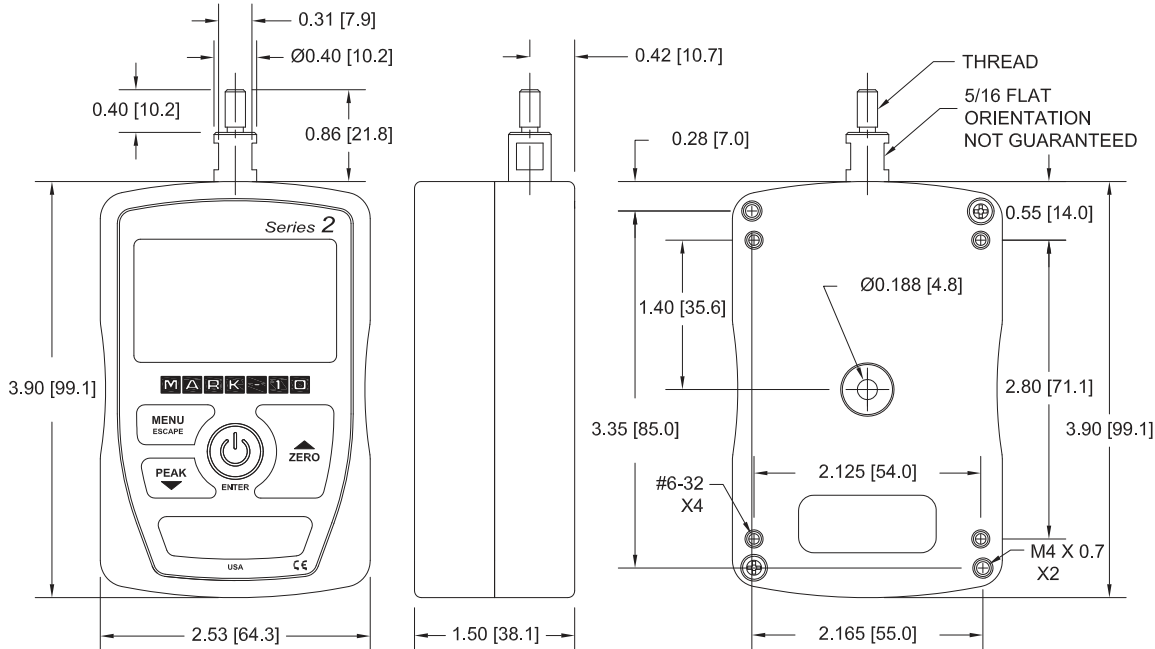

	Thread
M2-2 – M2-100	#10-32 UNF
M2-200 – M2-500	5/16-18 UNC