

# SERIES S0603

## Hi-Rel Surface Mount Chip Inductors

DASH NUMBER\*  
 INDUCTANCE (nH) ±5%  
 Q MINIMUM  
 INDUCTANCE & Q TEST FREQUENCY (MHz)  
 SRF MINIMUM (MHz)  
 MAXIMUM (MHz)  
 DC RESISTANCE (Ohms)  
 CURRENT RATING MAXIMUM (mA)

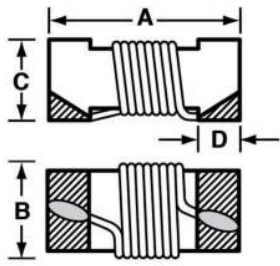

Actual Size (Max.)

### Physical Parameters

	Inches	Millimeters
A	0.058 - 0.062	1.473 - 1.575
B	0.028 - 0.035	0.711 - 0.889
C	0.040 Max.	1.016 Max.
D	0.011 - 0.010	0.279 - 0.381

**Operating Temperature Range** -55°C to +125°C

**Current Rating at 90°C Ambient** +35°C Rise

**Insulation Resistance at 100 Vdc** 1000 Mohm Min.

**Dielectric Withstanding Voltage (DWV)** 200 Vrms.

### Core Material / Termination

Al<sub>2</sub>O<sub>3</sub> / Sintered MoMn / Electroplated Ni / Electroplated Au Finish (RoHS)

- Termination Options:
1. Au Finish (RoHS)
  2. SnPb Solder
  3. Pb Free Solder (RoHS)

**Electrical Characteristics** Measured at +25°C

SERIES S0603						
-3N3J	3.3	18	250	6000	0.100	700
-5N6J	5.6	18	250	5800	0.190	700
-8N2J	8.2	24	250	4800	0.150	700
-10NJ	10.0	28	250	4800	0.160	700
-15NJ	15.0	32	250	4000	0.200	700
-22NJ	22.0	35	250	3000	0.220	700
-33NJ	33.0	37	250	2300	0.250	600
-39NJ	39.0	37	250	2200	0.280	600
-47NJ	47.0	35	200	2000	0.310	600
-56NJ	56.0	35	200	1900	0.340	600
-68NJ	68.0	34	200	1700	0.370	600
-82NJ	82.0	34	150	1700	0.570	400
-101NJ	100.0	31	150	1400	0.610	400
-151NJ	150.0	29	100	1300	0.980	280
-221NJ	220.0	22	100	1200	1.700	250
-271NJ	270.0	22	100	900	2.200	200

Inductance Tolerance Options J (± 5%), H (± 3%), G (± 2%), F (± 1%)

- |  |   |
|--|---|
| <b>S0603 Test Plan Advantages</b> <ul style="list-style-type: none"> <li>• Provides multiple screening alternatives</li> <li>• Eliminates necessity for SCD's</li> <li>• Provides quicker delivery</li> <li>• Reduces overall costs</li> </ul> | <b>Manufactured in Cleanroom</b> <ul style="list-style-type: none"> <li>• ISO 7 (@0.5 micron) Air Cleanliness Classification</li> <li>• Room Pressurization</li> <li>• Air Change Rate</li> <li>• HEPA Filter Leak Testing</li> </ul> |
|--|---|

**How To Order:**

**S0603 101N J 1 C**  
 (A) (B) (C) (D) (E)

(A) Inductor Series  
 (B) Inductance Value  
 (C) Inductance Tolerance  
 (D) Termination Finish  
 (E) Test Plan Screening

### S0603 Test Plan Options

Ordering Option Code		S	C	B	D	E	Y
Screening Level		MIL-STD-981 Class "S"	MIL-STD-981 Class "S" Modified	MIL-STD-981 Class "B"	MIL-STD-981 Class "B" Modified	High Temp	Commercial
Test	Method						
Thermal Shock	MIL-PRF-83446	25 Cycles 1/ (-55°C to +125°C)	25 Cycles (-55°C to +125°C)	25 Cycles 1/ (-55°C to +125°C)	25 Cycles (-55°C to +125°C)	5 Cycles (-55°C to +175°C)	
No-Load Burn-In	MIL-STD-981	125°C (96 hours)	125°C (96 hours)	125°C (96 hours)	125°C (96 hours)	200°C (96 hours)	
Dielectric Withstanding Voltage	MIL-PRF-83446	200 Vrms		200 Vrms			
Insulation Resistance	MIL-PRF-83446	1000 Mohms		1000 Mohms			
Electrical Characteristics: L, Q, DCR, SRF	MIL-PRF-83446	•	•	•	•	•	•
Radiographic Inspection	MIL-STD-981	•					
Visual & Dimensional Examination (external)	MIL-PRF-83446	•	•	•	•	•	•
* Electrical Characteristics (initial): L, Q, DCR, SRF	MIL-PRF-83446	•	•				
* Low Temperature Operation	MIL-PRF-83446	•	•				
* Temperature Rise	MIL-PRF-83446	•	•			•	
* Overload	MIL-PRF-83446	•	•			•	
* Moisture Resistance	MIL-PRF-83446	•					
* Electrical Characteristics: L and Q	MIL-PRF-83446	•	•				
* High Temperature Exposure	MIL-PRF-83446	•	•				
* Electrical Characteristics (final)	MIL-PRF-83446	•	•				
* Bond Strength	MIL-PRF-83446	•	•				
* Visual & Mechanical Examination (external)	MIL-PRF-83446	•	•				
* Visual & Mechanical Examination (internal)	MIL-STD-981	•					
* Solderability	MIL-PRF-83446	•	•				
* Electrical Characteristics (initial): L, Q, DCR, SRF	MIL-PRF-83446	•	•				
* Life	MIL-PRF-83446	2000 Hours (90°C Ambient)	500 Hours (90°C Ambient)			500 Hours (175°C Ambient)	
* Dielectric Withstanding Voltage	MIL-PRF-83446	80 Vrms	80 Vrms				
* Insulation Resistance	MIL-PRF-83446	1000 Mohms	1000 Mohms				
* Electrical Characteristics (final): L, Q, DCR, SRF	MIL-PRF-83446	•	•				
* Visual & Mechanical Examination (external)	MIL-PRF-83446	•	•				
Mechanical Shock/Vibration	MIL-STD-883						

\*Destructive Test Units Required

1/ Continually monitor continuity during the entire final cycle to verify no intermittent conditions.

# SERIES S0603

Hi-Rel Surface Mount  
Chip Inductors

## Suggested Land Patterns

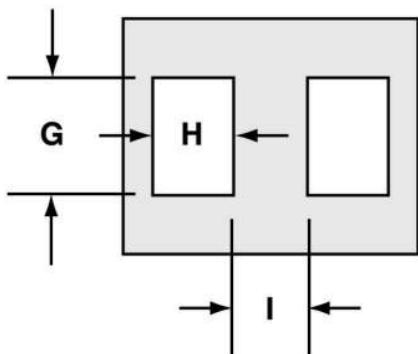

Delevan Series	G		H		I	
	Inches	mm	Inches	mm	Inches	mm
S0603 Series	0.040	1.016	0.025	0.635	0.025	0.635



## S-Parameters (Typical)

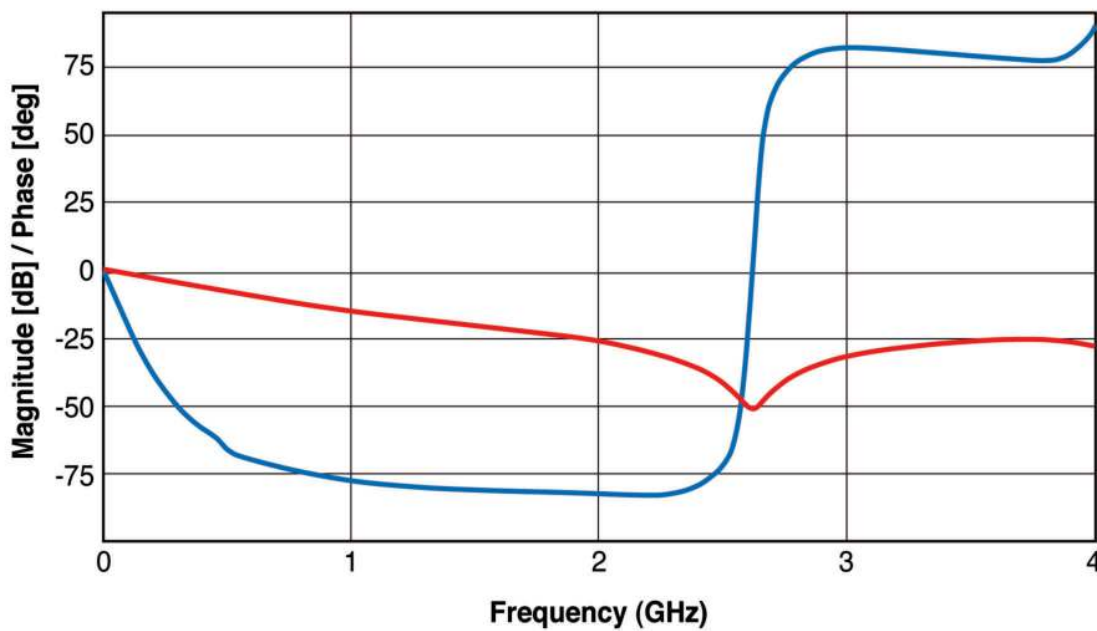

■ Magnitude [S(2,1)] S0603-68NK  
■ Phase [S(2,1)] S0603-68NK

All product specifications and data contained herein are subject to change without notice to improve reliability, function, performance, design or otherwise.

270 Quaker Rd., East Aurora NY 14052 • Phone 716-652-3600 • Fax 716-652-4814 • E-mail: [apisales@delevan.com](mailto:apisales@delevan.com) • [www.delevan.com](http://www.delevan.com)

