



# Omni Antenna 2,400-2,500 MHz N Type Female Connector

## Antennas Technical Data Sheet

PE51OM1045

### Features

- All weather operation
- Includes heavy duty steel mast mounting brackets
- PVC radome
- Integral two N-Female connector
- 2x2 MIMO capable
- 360° Omnidirectional Pattern

### Applications

- 2400 Band Operation
- Point to Multipoint and Non Line of Sight (NLOS)
- Applications
- 12 dBi gain

### Description

The PE51OM1045 from Pasternack is a high performance LTE outdoor 2x2 MIMO omnidirectional antenna designed for Cellular Networks. The PE51OM1045 operates from 2400 to 2500 MHz which is ideal for 4G, LTE, PCS applications. The Multi-Band design of the Pasternack PE51OM1045 antenna eliminates the need to purchase different antennas for each frequency. The same antenna can be used for a wide array of base station cellular applications where wide coverage is desired. Pasternack's PE51OM1045 can be used to distribute Cellular telecommunication signals over a large area.

The omnidirectional antenna with vertical/horizontal polarization PE51OM1045 from Pasternack has two Type N connectors and 12 dBi of gain. The Type N connectorized PE51OM1045 antenna from Pasternack excels in large open areas. The mounting bracket and hardware are included for easy installation. Our Pasternack ISO 9001:2008 registered facilities in Irvine, CA ships all Type N RF, microwave and millimeter wave waveguide components from stock the same day you purchase them. Pasternack offers the broadest and deepest in-stock inventory and is where to buy 5G antennas. Our expert technical support and friendly, knowledgeable customer service personnel are available to assist you with your particular needs for LTE outdoor omnidirectional 5G cellular antennas.

### Configuration

Design	Omni
Band Type	Single
Radiation Pattern	Omni Directional
Polarization	Vertical/Horizontal
Connector Type	N Female
Number of Ports	2
Lightning Protection	DC Ground

### Electrical Specifications

Description	Minimum	Typical	Maximum	Units
Frequency Range	2,400		2,500	MHz
Input VSWR		1.5:1		
Impedance		50		Ohms
Gain		12		dBi
Horizontal (Azimuth) Beam Width		Omnidirectional		
Vertical (Elevation) Beam Width		7		Degrees
Input Power			50	Watts

Click the following link (or enter part number in "SEARCH" on website) to obtain additional part information including price, inventory and certifications: [Omni Antenna 2,400-2,500 MHz N Type Female Connector PE51OM1045](#)



## Omni Antenna 2,400-2,500 MHz N Type Female Connector

### Antennas Technical Data Sheet

PE51OM1045

#### Mechanical Specifications

Radome Material	PVC
<b>Size</b>	
Overall Length	45.66929 in [116 cm]
Width	2.99213 in [76 mm]
Height	2.99213 in [76 mm]
Mounting Mast Diameter	1.18 to 2.36 in [29.97 to 59.94 mm]
Weight	6.61 lbs [3 kg]

#### Environmental Specifications

<b>Temperature</b>	
Operating Range	-40 to +60 deg C
Wind Loading	134.216 MPH [216 KPH]

**Compliance Certifications** (see [product page](#) for current document)

#### Plotted and Other Data

Notes:

Omni Antenna 2,400-2,500 MHz N Type Female Connector from Pasternack Enterprises has same day shipment for domestic and International orders. Our RF, microwave and millimeter wave products maintain a 99.4% availability and are part of the broadest selection in the industry.

Click the following link (or enter part number in "SEARCH" on website) to obtain additional part information including price, inventory and certifications: [Omni Antenna 2,400-2,500 MHz N Type Female Connector PE51OM1045](#)

URL: <https://www.pasternack.com/single-antenna-2.4-2.5-ghz-0-gain-n-pe51om1045-p.aspx>

The information contained in this document is accurate to the best of our knowledge and representative of the part described herein. It may be necessary to make modifications to the part and/or the documentation of the part, in order to implement improvements. Pasternack reserves the right to make such changes as required. Unless otherwise stated, all specifications are nominal. Pasternack does not make any representation or warranty regarding the suitability of the part described herein for any particular purpose, and Pasternack does not assume any liability arising out of the use of any part or documentation.

# PE51OM1045 CAD Drawing

Omni Antenna 2,400-2,500 MHz N Type Female Connector

REVISIONS			
REV.	DESCRIPTION	DATE	APPROVED
A	INITIAL RELEASE	2/11/2022	K. HIETPAS

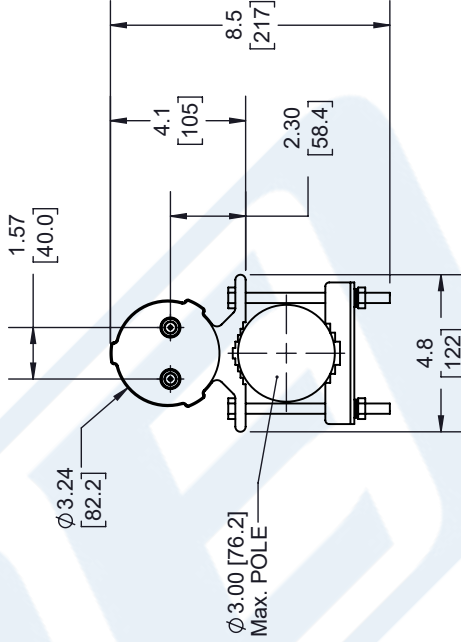
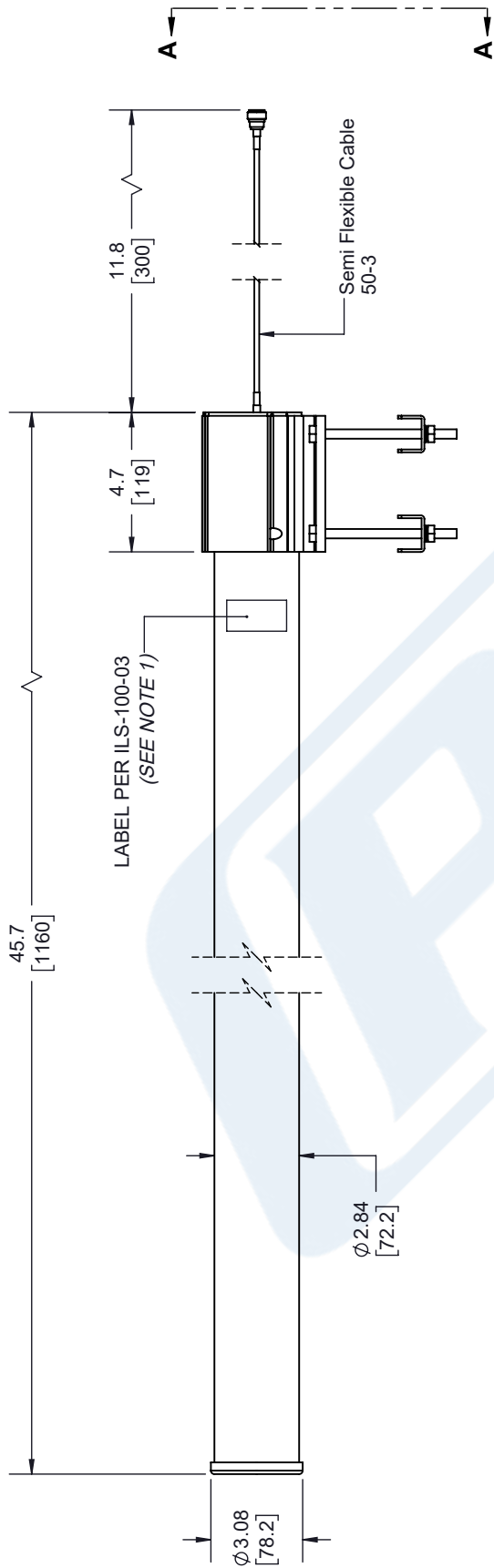

VIEW A-A

UNLESS OTHERWISE SPECIFIED  
LEADING DIMENSIONS ARE INCHES  
DIMENSIONS IN [ ] ARE MILLIMETERS

TOLERANCES:  
 .X = ±.2 [5.08]    FRACTIONS ±.1/32  
 .XX = ±.02 [51]    ANGLES ± 1°  
 .XXX = ±.005 [13]    CABLE LENGTH (L), TOLERANCES:  
 L ≤ 12 [305] < L ≤ 60 [1524] = +1 [25] / -0  
 60 [1524] < L ≤ 120 [3048] = +4 [102] / -0  
 120 [3048] < L ≤ 300 [7620] = +6 [152] / -0  
 300 [7620] < L = +5% / -0

**NOTES:**

- LABEL PER ILS-100-03. FOR INTERNAL USE ONLY.  
LABEL LOCATION FOR REFERENCE ONLY.

THESE COMMODITIES, TECHNOLOGY OR SOFTWARE WERE EXPORTED FROM THE UNITED STATES IN ACCORDANCE WITH THE EXPORT ADMINISTRATION REGULATIONS. DIVERSION CONTRARY TO U.S. LAW PROHIBITED.

<p>THIRD-ANGLE PROJECTION</p> <p>THE INFORMATION AND DESIGN IN THIS DOCUMENT IS THE PROPERTY OF PASTERNAK CORPORATION ALL RIGHTS RESERVED.</p> <p>SHEET 1 OF 1</p> <p>SCALE N/A</p>	<p>Pasternack Enterprises, Inc. P.O. Box 16759, Irvine, CA 92623. Phone: 1.949.261.1920   1.866.727.8376 Fax: 1.949.261.7451 Website: www.pasternack.com E-mail: sales@pasternack.com</p>	REV	A
		SIZE	A
CAGE CODE	53919	DRAWN BY	K.DANG
ITEM NO.	PE51OM1045		