

## Digital tone control audio processor

Datasheet - production data

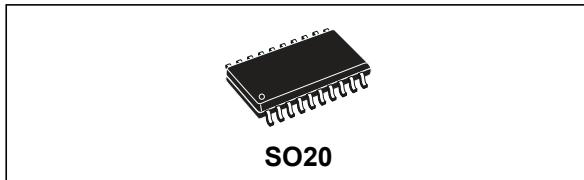

### Description

The TDA7449 is a volume tone (bass and treble) balance (left/right) processor for quality audio applications in TV systems. Selectable input gain for optimal adaptation to different sources is provided. A serial bus controls all functions.

The AC signal setting is obtained by resistor networks and switches combined with operational amplifiers.

Bipolar/CMOS technology used allows obtaining low distortion, low noise and DC stepping.

### Features

- Input multiplexer
  - Two stereo inputs
  - Selectable input gain for optimal adaptation to different sources
- One stereo output
- Treble and bass control in 2.0 db steps
- Volume control in 1.0 db steps
- Two speaker attenuators:
  - Two independent speaker controls in 1.0 db steps to facilitate balance
  - Independent mute function
- All functions are programmable via serial bus

Table 1. Device summary

Order code	Package	Packing
TDA7449D13TR	SO20	Tape and reel

Figure 1. Block diagram

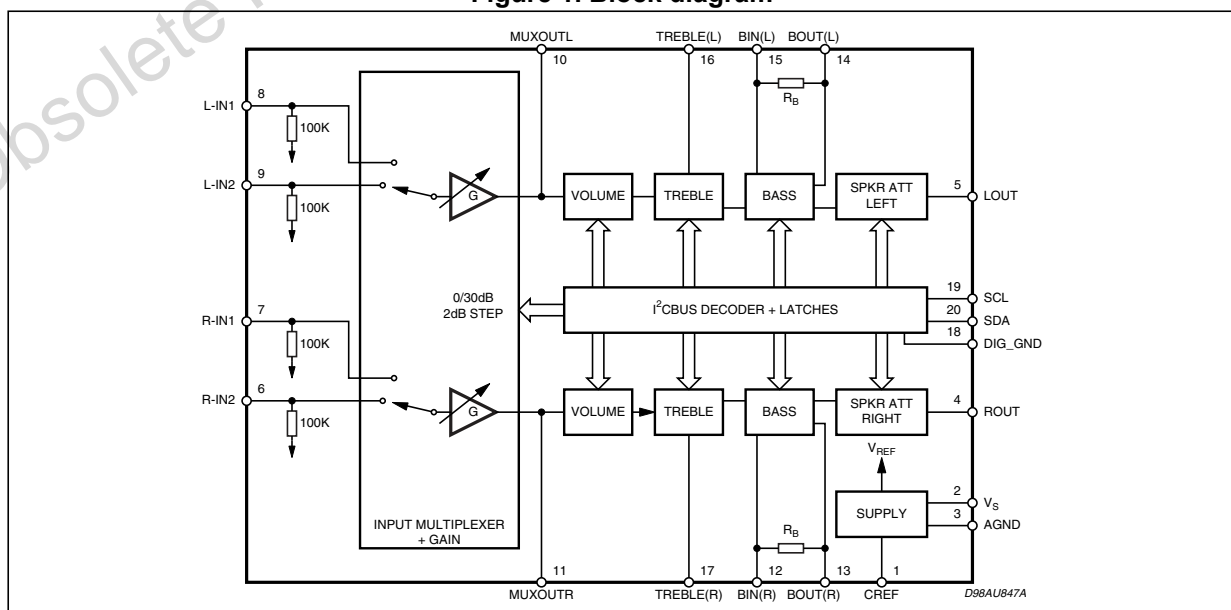

# Contents

<b>1</b>	<b>Overview</b> .....	<b>3</b>
<b>2</b>	<b>Electrical characteristics and test circuit</b> .....	<b>4</b>
<b>3</b>	<b>Application recommendations</b> .....	<b>7</b>
	3.1 Bass, stages .....	7
	3.2 Treble stage .....	7
	3.3 CREF .....	8
<b>4</b>	<b>I<sup>2</sup>C bus interface</b> .....	<b>9</b>
	4.1 Data validity .....	9
	4.2 Start and stop conditions .....	9
	4.3 Byte format .....	9
	4.4 Acknowledge .....	9
	4.5 Transmission without acknowledge .....	9
<b>5</b>	<b>Software specifications</b> .....	<b>11</b>
	5.1 Interface protocol .....	11
<b>6</b>	<b>Examples</b> .....	<b>12</b>
	6.1 No incremental bus .....	12
	6.2 Incremental bus .....	12
<b>7</b>	<b>Data bytes</b> .....	<b>13</b>
<b>8</b>	<b>Package information</b> .....	<b>19</b>
<b>9</b>	<b>Revision history</b> .....	<b>20</b>

# 1 Overview

**Table 2. Absolute maximum ratings**

Symbol	Parameter	Value	Unit
$V_S$	Operating supply voltage	10.5	V
$T_{amb}$	Operating ambient temperature	0 to 70	°C
$T_{stg}$	Storage temperature range	-55 to 150	°C

**Figure 2. Pin connections**

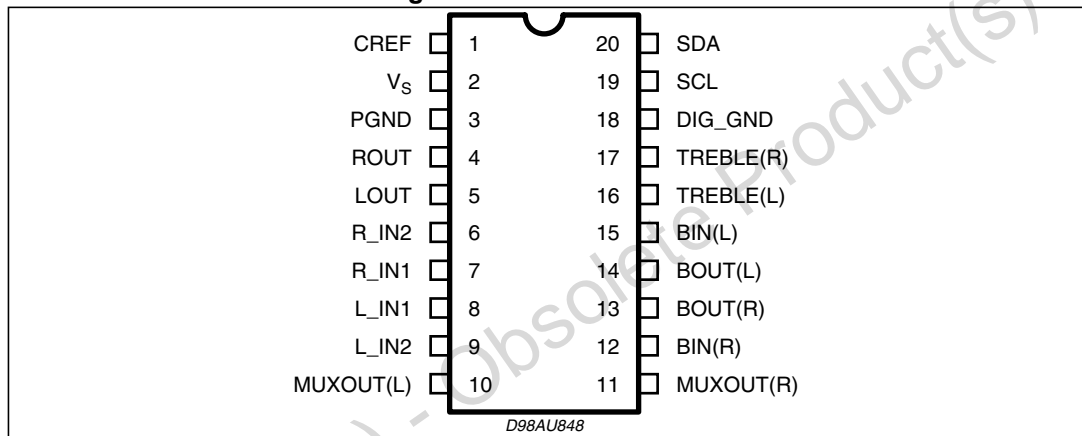

**Table 3. Thermal data**

Symbol	Parameter	Value	Unit
$R_{th\ j-pin}$	Thermal resistance junction pins	85	°C/W

**Table 4. Quick reference data**

Symbol	Parameter	Min.	Typ.	Max.	Unit
$V_S$	Supply voltage	6	9	10.2	V
$V_{CL}$	Max input signal handling	2			$V_{RMS}$
THD	Total harmonic distortion $V = 0.1\ V_{rms}$ $f = 1\ kHz$		0.01	0.1	%
S/N	Signal-to-noise ratio $V_{out} = 1\ V_{rms}$ (mode = OFF)		106		dB
$S_C$	Channel separation $f = 1\ kHz$		90		dB
	Input gain (2 dB step)	0		30	dB
	Volume control (1 dB step)	-47		0	dB
	Treble control (2 dB step)	-14		14	dB
	Bass control (2 dB step)	-14		14	dB
	Balance control 1 dB step	-79		0	dB
	Mute attenuation		100		dB

## 2 Electrical characteristics and test circuit

**Table 5. Electrical characteristics** (refer to the test circuit  $T_{amb} = 25\text{ °C}$ ,  $V_S = 9\text{ V}$ ,  $R_L = 10\text{ k}\Omega$ ,  $R_G = 600\text{ }\Omega$ , all controls flat ( $G = 0\text{ dB}$ ), unless otherwise specified)

Symbol	Parameter	Test Condition	Min.	Typ.	Max.	Unit
<b>Supply</b>						
$V_S$	Supply voltage		6	9	10.2	V
$I_S$	Supply current			7		mA
SVR	Ripple rejection		60	90		dB
<b>Input stage</b>						
$R_{IN}$	Input resistance			100		k $\Omega$
$V_{CL}$	Clipping level	THD = 0.3%	2	2.5		V <sub>rms</sub>
$S_{IN}$	Input separation	The selected input is grounded through a 2.2 $\mu$ capacitor	80	100		dB
$G_{inmin}$	Minimum input gain		-1	0	1	dB
$G_{inmax}$	Maximum input gain			30		dB
$G_{step}$	Step resolution			2		dB
<b>Volume control</b>						
$C_{RANGE}$	Control range		45	47	49	dB
$A_{VMAX}$	Max. attenuation		45	47	49	dB
$A_{STEP}$	Step resolution		0.5	1	1.5	dB
$E_A$	Attenuation set error	$A_V = 0\text{ to }-24\text{ dB}$	-1.0	0	1.0	dB
		$A_V = -24\text{ to }-47\text{ dB}$	-1.5	0	1.5	dB
$E_T$	Tracking error	$A_V = 0\text{ to }-24\text{ dB}$		0	1	dB
		$A_V = -24\text{ to }-47\text{ dB}$		0	2	dB
$V_{DC}$	DC step	adjacent attenuation steps		0	3	mV
		from 0 dB to $A_V$ max		0.5		mV
$A_{mute}$	Mute attenuation		80	100		dB
<b>Bass control (1)</b>						
$G_b$	Control range	Max. boost/cut	+12.0	+14.0	+16.0	dB
$B_{STEP}$	Step resolution		1	2	3	dB
$R_B$	Internal feedback resistance		18.75	25	31.25	K $\Omega$
<b>Treble control (1)</b>						
$G_t$	Control range	Max. boost/cut	+13.0	+14.0	+15.0	dB
$T_{STEP}$	Step resolution		1	2	3	dB

**Table 5. Electrical characteristics** (refer to the test circuit  $T_{amb} = 25\text{ °C}$ ,  $V_S = 9\text{ V}$ ,  $R_L = 10\text{ k}\Omega$ ,  $R_G = 600\text{ }\Omega$ , all controls flat ( $G = 0\text{ dB}$ ), unless otherwise specified) (continued)

Symbol	Parameter	Test condition	Min.	Typ.	Max.	Unit
<b>Speaker attenuators</b>						
$C_{RANGE}$	Control range			76		dB
$S_{STEP}$	Step resolution		0.5	1	1.5	dB
$E_A$	Attenuation set error	$A_V = 0\text{ to }-20\text{ dB}$	-1.5	0	1.5	dB
		$A_V = -20\text{ to }-56\text{ dB}$	-2	0	2	dB
$V_{DC}$	DC Step	adjacent attenuation steps		0	3	mV
$A_{mute}$	Mute attenuation		80	100		dB
<b>Audio outputs</b>						
$V_{CLIP}$	Clipping level	$d = 0.3\%$	2.1	2.6		$V_{RMS}$
$R_L$	Output load resistance		2			$k\Omega$
$R_O$	Output impedance		10	40	70	W
$V_{DC}$	DC voltage level			3.8		V
<b>General</b>						
$E_{NO}$	Output noise	All gains = 0dB; BW = 20Hz to 20KHz flat		5	15	$\mu V$
$E_t$	Total tracking error	$A_V = 0\text{ to }-24\text{ dB}$		0	1	dB
		$A_V = -24\text{ to }-47\text{ dB}$		0	2	dB
S/N	Signal-to-Noise ratio	All gains 0dB; $V_O = 1V_{RMS}$ ;		106		dB
$S_C$	Channel separation left/right		80	100		dB
d	Distortion	$A_V = 0$ ; $V_I = 1V_{RMS}$ ;		0.01	0.08	%
<b>Bus input</b>						
$V_{IL}$	Input low voltage				1	V
$V_{IH}$	Input high voltage		3			V
$I_{IN}$	Input current	$V_{IN} = 0.4\text{ V}$	-5		5	$\mu A$
$V_O$	Output voltage SDA acknowledge	$I_O = 1.6\text{ mA}$		0.4	0.8	V

- Note:**
1. The device is functionally good at  $V_S = 5\text{ V}$ . A step down on  $V_S$  to  $4\text{ V}$  doesn't reset the device.
  2. Bass and treble response: the center frequency and the response quality can be chosen by the external circuitry.

Figure 3. Test circuit

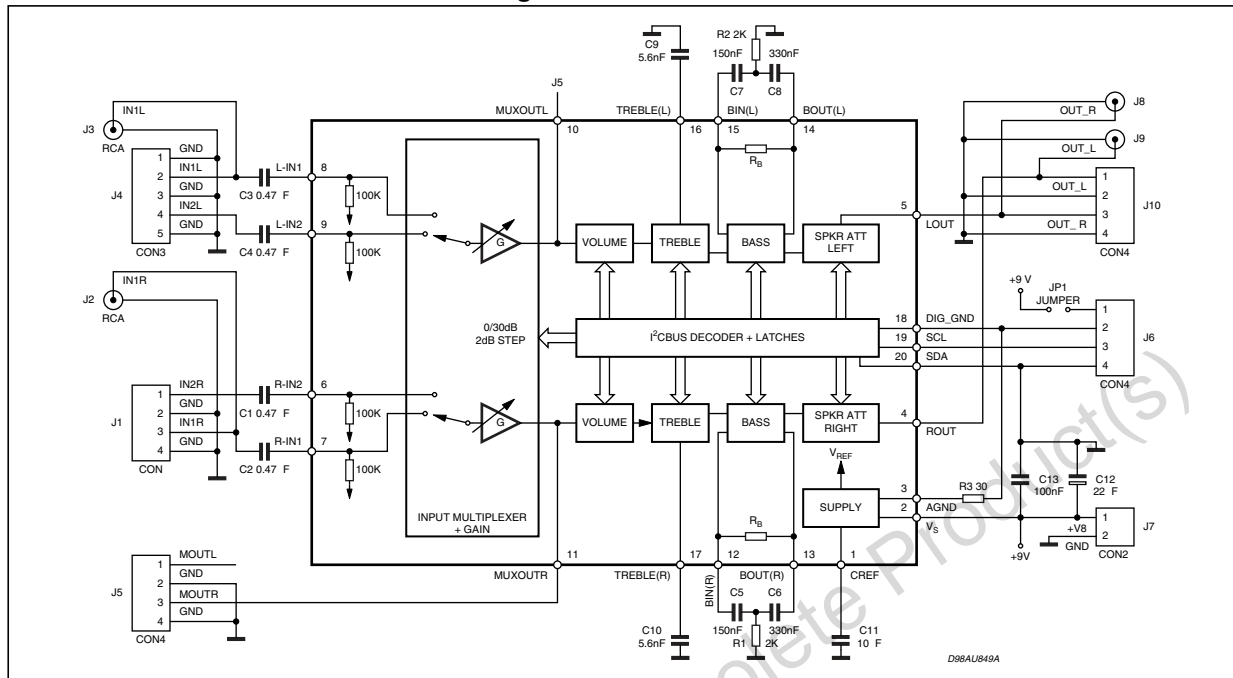

Obsolete Product(s) - Obsolete Product(s)

### 3 Application recommendations

The first and the last stages are volume control blocks. The control range is 0 to -47 dB (mute) for the first one and 0 to -79 dB (mute) for the last one. Both of them have 1 dB step resolution. The very high resolution allows the implementation of systems free from any noisy acoustical effect. The TDA7449 audio processor provides dual-band tone control. Typical responses are shown in [Figure 5](#) through [9](#).

#### 3.1 Bass stage

The bass cell has an internal resistor  $R_i = 25 \text{ k}\Omega$  typical. Several filter types can be implemented, connecting external components to the bass IN and OUT pins. [Figure 4](#) refers to a basic T-type bandpass filter. The filter component values  $R_1$  internal  $F_C$ , the gain  $A_V$  at max. boost and the filter Q factor are calculated as given below.

Figure 4. T bandpass filter

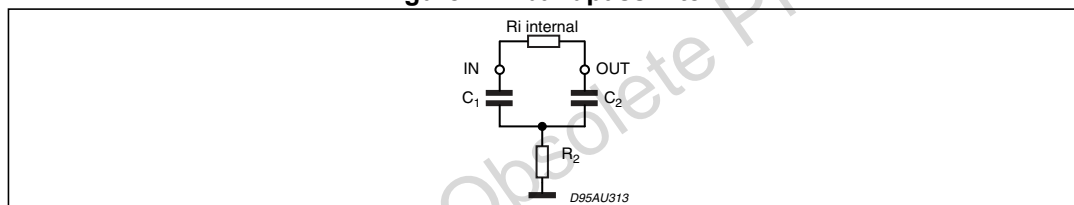

$$F_C = \frac{1}{2 \cdot \pi \cdot \sqrt{R_1 \cdot R_2 \cdot C_1 \cdot C_2}}$$

$$A_V = \frac{R_2 C_2 + R_2 C_1 + R_i C_1}{R_2 C_1 + R_2 C_2}$$

$$Q = \frac{\sqrt{R_1 \cdot R_2 \cdot C_1 \cdot C_2}}{R_2 C_1 + R_2 C_2}$$

Once the  $F_C$ ,  $A_V$ , and  $R_i$  internal values are fixed, the external component values will be:

$$C_1 = \frac{A_V - 1}{2 \cdot \pi \cdot F_C \cdot R_i \cdot Q} \quad C_2 = \frac{Q^2 \cdot C_1}{A_V - 1 - Q^2}$$

$$R_2 = \frac{A_V - 1 - Q^2}{2 \cdot \pi \cdot C_1 \cdot F_C \cdot (A_V - 1) \cdot Q}$$

#### 3.2 Treble stage

The treble stage is a high-pass filter whose time constant is fixed by an internal resistor (25 k $\Omega$  typical) and an external capacitor connected between the treble pins and ground.

#### 3.3 CREF

The recommended 10  $\mu\text{F}$  reference capacitor (CREF) value can be reduced to 4.7  $\mu\text{F}$  if the application requires faster power ON.

Figure 5. THD vs. frequency

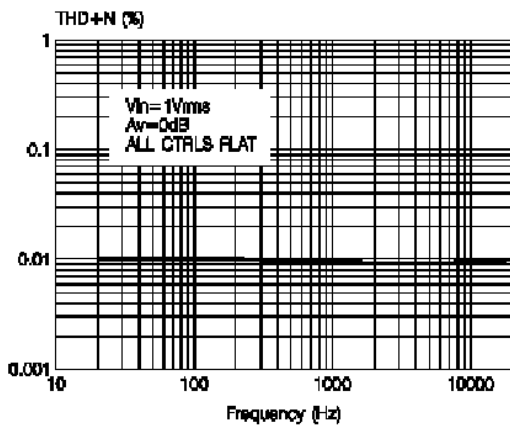

Figure 6. Bass response

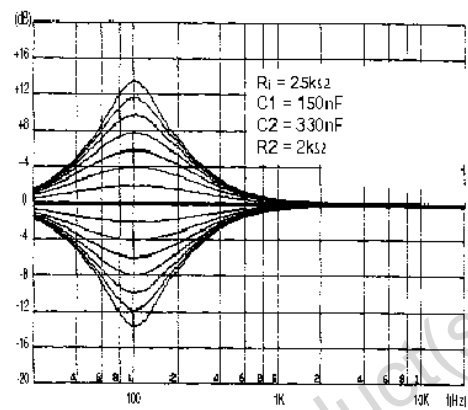

Figure 7. THD vs.  $R_{LOAD}$

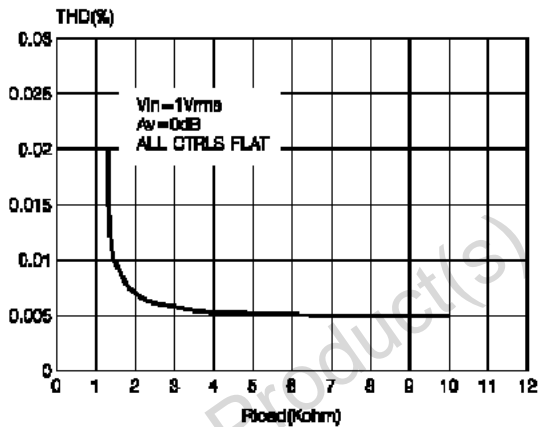

Figure 8. Treble response

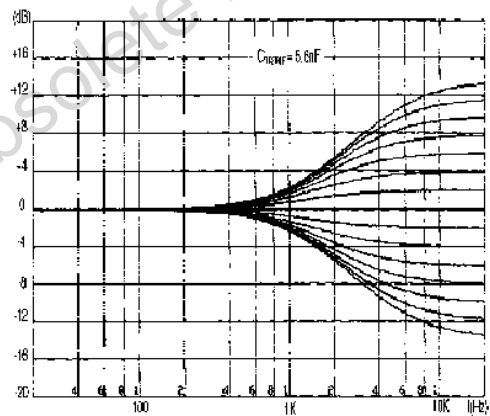
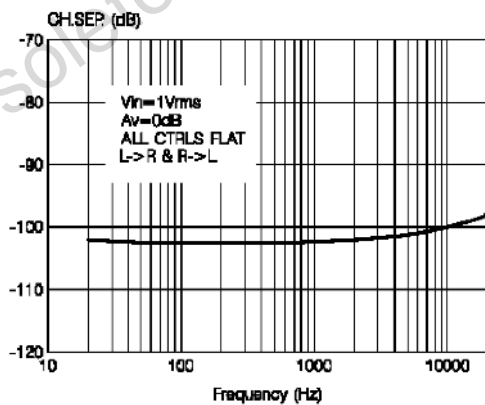

Figure 9. Channel separation vs. frequency





## 4 I<sup>2</sup>C bus interface

Data transmission from the microprocessor to the TDA7449 and vice versa takes place through the 2-wire I<sup>2</sup>C bus interface, consisting of the two lines SDA and SCL (pull-up resistors to the positive supply voltage must be connected).

### 4.1 Data validity

As shown in [Figure 10](#), the data on the SDA line must be stable during the high period of the clock. The HIGH and LOW state of the data line can only change when the clock signal on the SCL line is LOW.

### 4.2 Start and stop conditions

As shown in [Figure 11](#), a start condition is a HIGH-to-LOW transition of the SDA line while SCL is HIGH. The stop condition is a LOW-to-HIGH transition of the SDA line while SCL is HIGH.

### 4.3 Byte format

Every byte transferred on the SDA line must contain 8 bits. Each byte must be followed by an acknowledge bit. The MSB is transferred first.

### 4.4 Acknowledge

The master ( $\mu$ P) puts a resistive HIGH level on the SDA line during the acknowledge clock pulse (see [Figure 12](#)). The peripheral (audio processor) that acknowledges has to pull down (LOW) the SDA line during this clock pulse.

The audio processor which has been addressed has to generate an acknowledge after the reception of each byte, otherwise the SDA line remains at the HIGH level during the ninth clock pulse time. In this case the master transmitter can generate the STOP information in order to abort the transfer.

### 4.5 Transmission without acknowledge

Instead of detecting the acknowledge from the audio processor, the  $\mu$ P can use a simpler transmission which is to simply wait one clock pulse without checking the slave acknowledge and send the new data.

This is of course a riskier approach.

Figure 10. Data validity on the I<sup>2</sup>C bus

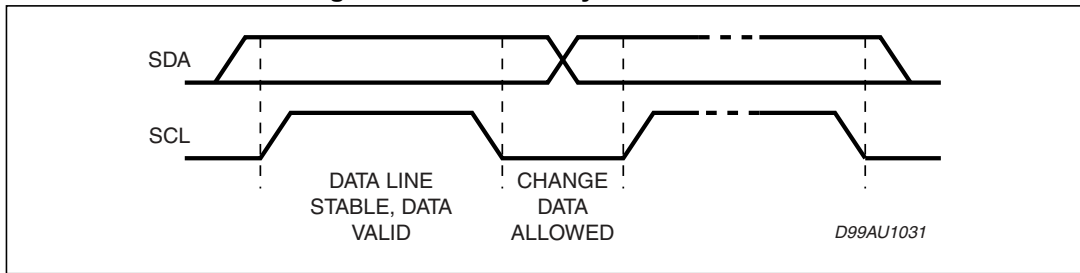

Figure 11. Timing diagram of I<sup>2</sup>C bus

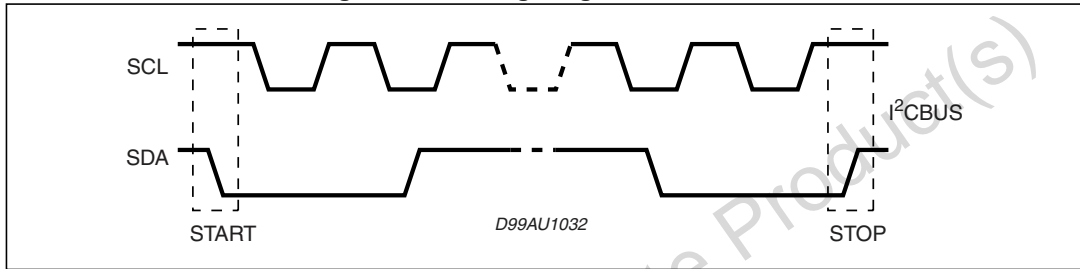
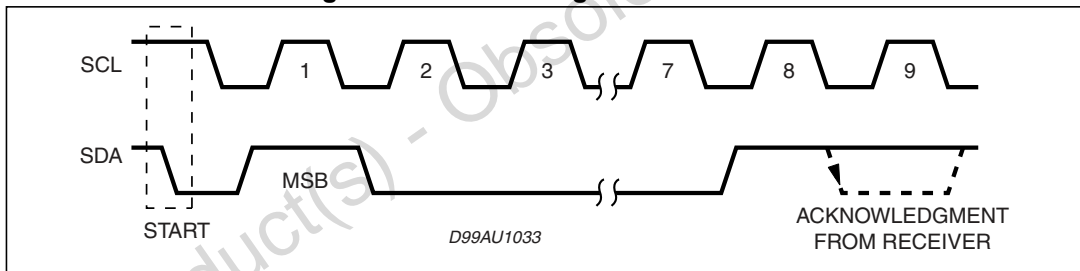

Figure 12. Acknowledge on the I<sup>2</sup>C bus



## 5 Software specifications

### 5.1 Interface protocol

The interface protocol comprises:

- A start condition (S)
- A chip address byte, containing the TDA7449 address
- A subaddress byte
- A sequence of data (N byte + acknowledge)
- A stop condition (P)

Figure 13. Interface protocol

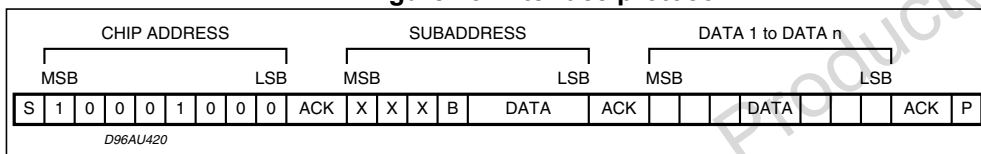

ACK = Acknowledge

S = Start

P = Stop

A = Address

B = Auto-increment

## 6 Examples

### 6.1 No incremental bus

The TDA7449 receives a start condition, the correct chip address, a subaddress with B = 0 (no incremental bus), N-data (all these data concern the subaddress selected), a stop condition.

Figure 14. No incremental bus (B = 0)

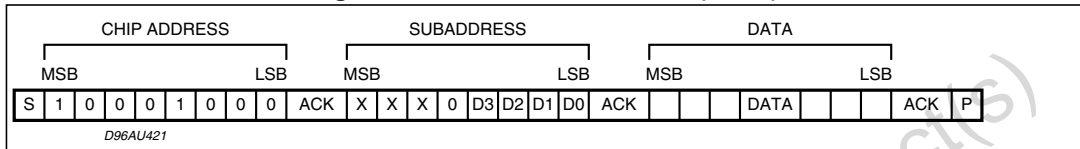

### 6.2 Incremental bus

The TDA7449 receives a start condition, the correct chip address, a subaddress with B = 1 (incremental bus): now it is in a loop condition with an autoincrease of the subaddress whereas SUBADDRESS from "XXX1000" to "XXX1111" of DATA are ignored.

DATA 1 concern the subaddress sent, and DATA 2 concerns the subaddress sent plus one in the loop etc, and at the end it receives the stop condition.

Figure 15. Incremental bus (B=1)

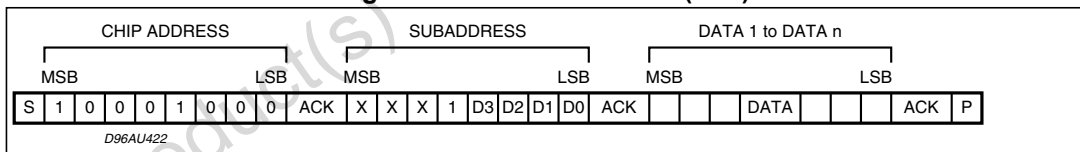

Table 6. Power-on reset condition

Input selection	IN2
Input gain	28 dB
Volume	Mute
Bass	0 dB
Treble	2 dB
Speaker	Mute

## 7 Data bytes

Address = 88 hex (Addr: OPEN)

**Table 7. Function selection: first byte (subaddress)**

MSB							LSB		Subaddress
D7	D6	D5	D4	D3	D2	D1	D0		
X	X	X	B	0	0	0	0	Input select	
X	X	X	B	0	0	0	1	Input gain	
X	X	X	B	0	0	1	0	Volume	
X	X	X	B	0	0	1	1	Not allowed	
X	X	X	B	0	1	0	0	Bass	
X	X	X	B	0	1	0	1	Treble	
X	X	X	B	0	1	1	0	Speaker attenuate "R"	
X	X	X	B	0	1	1	1	Speaker attenuate "L"	

B = 1: incremental bus active

B = 0: no incremental bus

X = don't care

**Table 8. Input selection**

MSB							LSB		Input multiplexer
D7	D6	D5	D4	D3	D2	D1	D0		
X	X	X	X	X	X	0	0	Not allowed	
X	X	X	X	X	X	0	1	Not allowed	
X	X	X	X	X	X	1	0	IN2	
X	X	X	X	X	X	1	1	IN1	

Table 9. Input gain selection

MSB				LSB				Input gain 2 dB steps
D7	D6	D5	D4	D3	D2	D1	D0	
				0	0	0	0	0 dB
				0	0	0	1	2 dB
				0	0	1	0	4 dB
				0	0	1	1	6 dB
				0	1	0	0	8 dB
				0	1	0	1	10 dB
				0	1	1	0	12 dB
				0	1	1	1	14 dB
				1	0	0	0	16 dB
				1	0	0	1	18 dB
				1	0	1	0	20 dB
				1	0	1	1	22 dB
				1	1	0	0	24 dB
				1	1	0	1	26 dB
				1	1	1	0	28 dB
				1	1	1	1	30 dB

Gain = 0 to 30 dB

Table 10. Volume selection

MSB				LSB				Volume 1 dB steps
D7	D6	D5	D4	D3	D2	D1	D0	
					0	0	0	0 dB
					0	0	1	-1 dB
					0	1	0	-2 dB
					0	1	1	-3 dB
					1	0	0	-4 dB
					1	0	1	-5 dB
					1	1	0	-6 dB
					1	1	1	-7 dB
	0	0	0	0				0 dB
	0	0	0	1				-8 dB
	0	0	1	0				-16 dB
	0	0	1	1				-24 dB
	0	1	0	0				-32 dB
	0	1	0	1				-40 dB
	X	1	1	1	X	X	X	Mute

Volume = 0 to 47dB/mute

Table 11. Bass selection

MSB							LSB	Bass 2 dB steps
D7	D6	D5	D4	D3	D2	D1	D0	
				0	0	0	0	-14 dB
				0	0	0	1	-12 dB
				0	0	1	0	-10 dB
				0	0	1	1	-8 dB
				0	1	0	0	-6 dB
				0	1	0	1	-4 dB
				0	1	1	0	-2 dB
				0	1	1	1	0 dB
				1	1	1	1	0 dB
				1	1	1	0	2 dB
				1	1	0	1	4 dB
				1	1	0	0	6 dB
				1	0	1	1	8 dB
				1	0	1	0	10 dB
				1	0	0	1	12 dB
				1	0	0	0	14 dB

Table 12. Treble selection

MSB							LSB	Treble 2 dB steps
D7	D6	D5	D4	D3	D2	D1	D0	
				0	0	0	0	-14 dB
				0	0	0	1	-12 dB
				0	0	1	0	-10 dB
				0	0	1	1	-8 dB
				0	1	0	0	-6 dB
				0	1	0	1	-4 dB
				0	1	1	0	-2 dB
				0	1	1	1	0 dB
				1	1	1	1	0 dB
				1	1	1	0	2 dB
				1	1	0	1	4 dB
				1	1	0	0	6 dB
				1	0	1	1	8 dB
				1	0	1	0	10 dB
				1	0	0	1	12 dB
				1	0	0	0	14 dB

Table 13. Speaker attenuation selection

MSB				LSB				Speaker attenuation 1 dB
D7	D6	D5	D4	D3	D2	D1	D0	
					0	0	0	0 dB
					0	0	1	-1 dB
					0	1	0	-2 dB
					0	1	1	-3 dB
					1	0	0	-4 dB
					1	0	1	-5 dB
					1	1	0	-6 dB
					1	1	1	-7 dB
	0	0	0	0				0 dB
	0	0	0	1				-8 dB
	0	0	1	0				-16 dB
	0	0	1	1				-24 dB
	0	1	0	0				-32 dB
	0	1	0	1				-40 dB
	0	1	1	0				-48 dB
	0	1	1	1				-56 dB
	1	0	0	0				-64 dB
	1	0	0	1				-72 dB
	1	1	1	1	X	X	X	Mute

Speaker attenuation = 0 to -79dB/mute



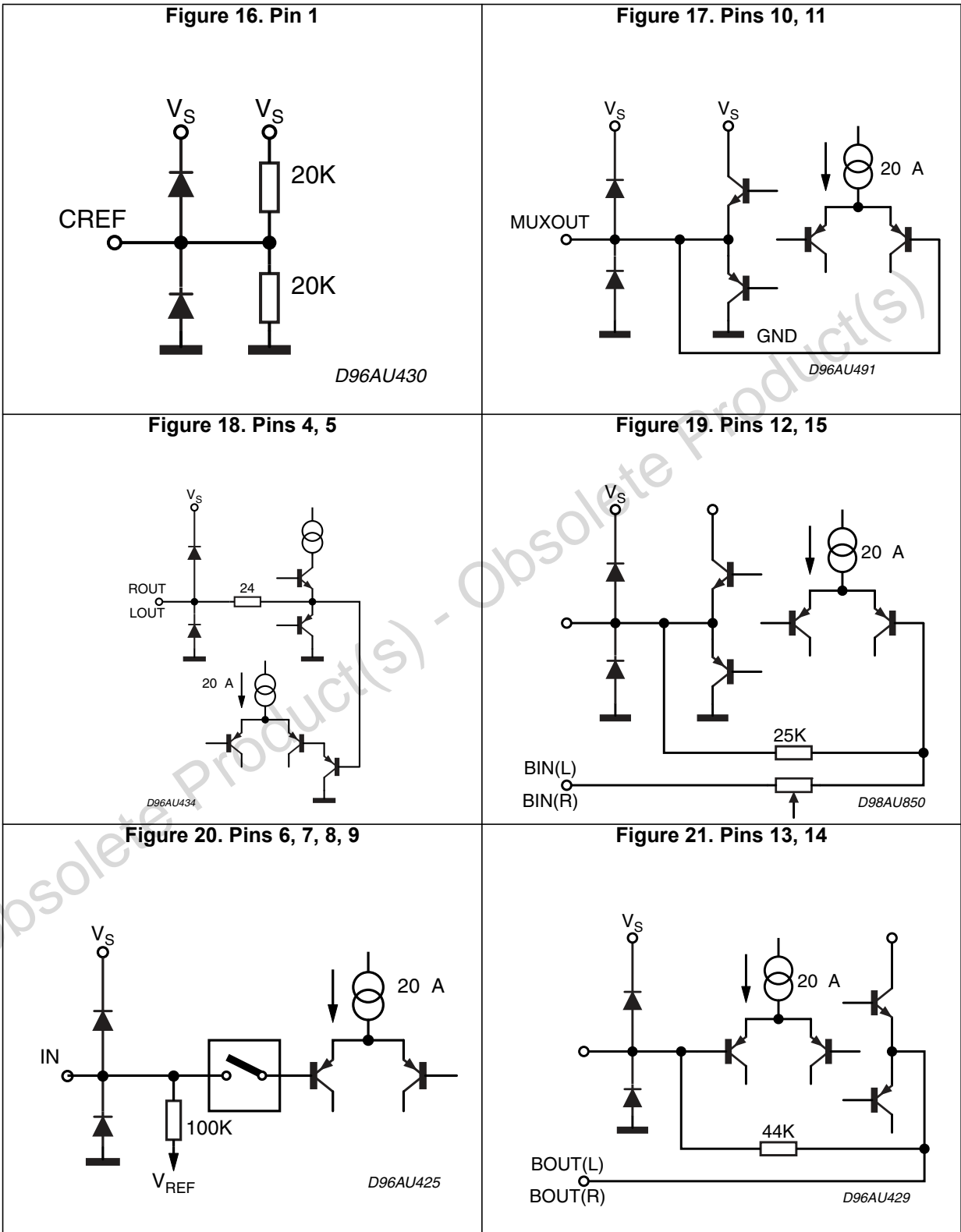

Figure 22. Pins 16, 17

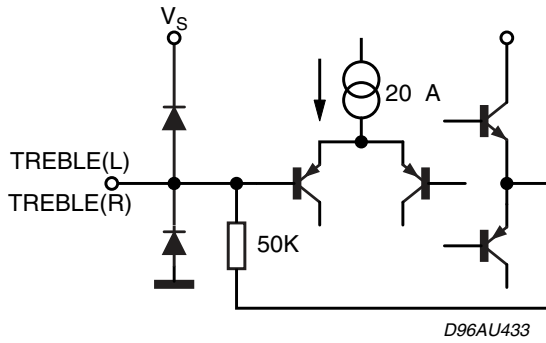

Figure 23. Pin 20

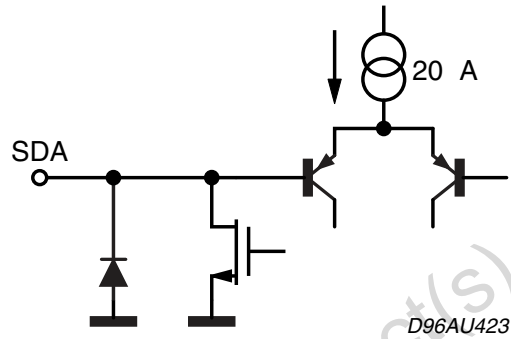
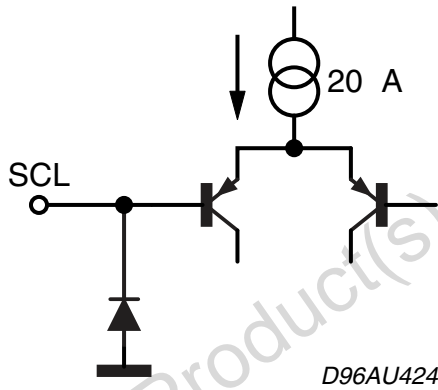

Figure 24. Pin 19



# 8 Package information

In order to meet environmental requirements, ST offers these devices in different grades of ECOPACK<sup>®</sup> packages, depending on their level of environmental compliance. ECOPACK<sup>®</sup> specifications, grade definitions and product status are available at: [www.st.com](http://www.st.com). ECOPACK<sup>®</sup> is an ST trademark.

**Figure 25. SO20 mechanical data & package dimensions**

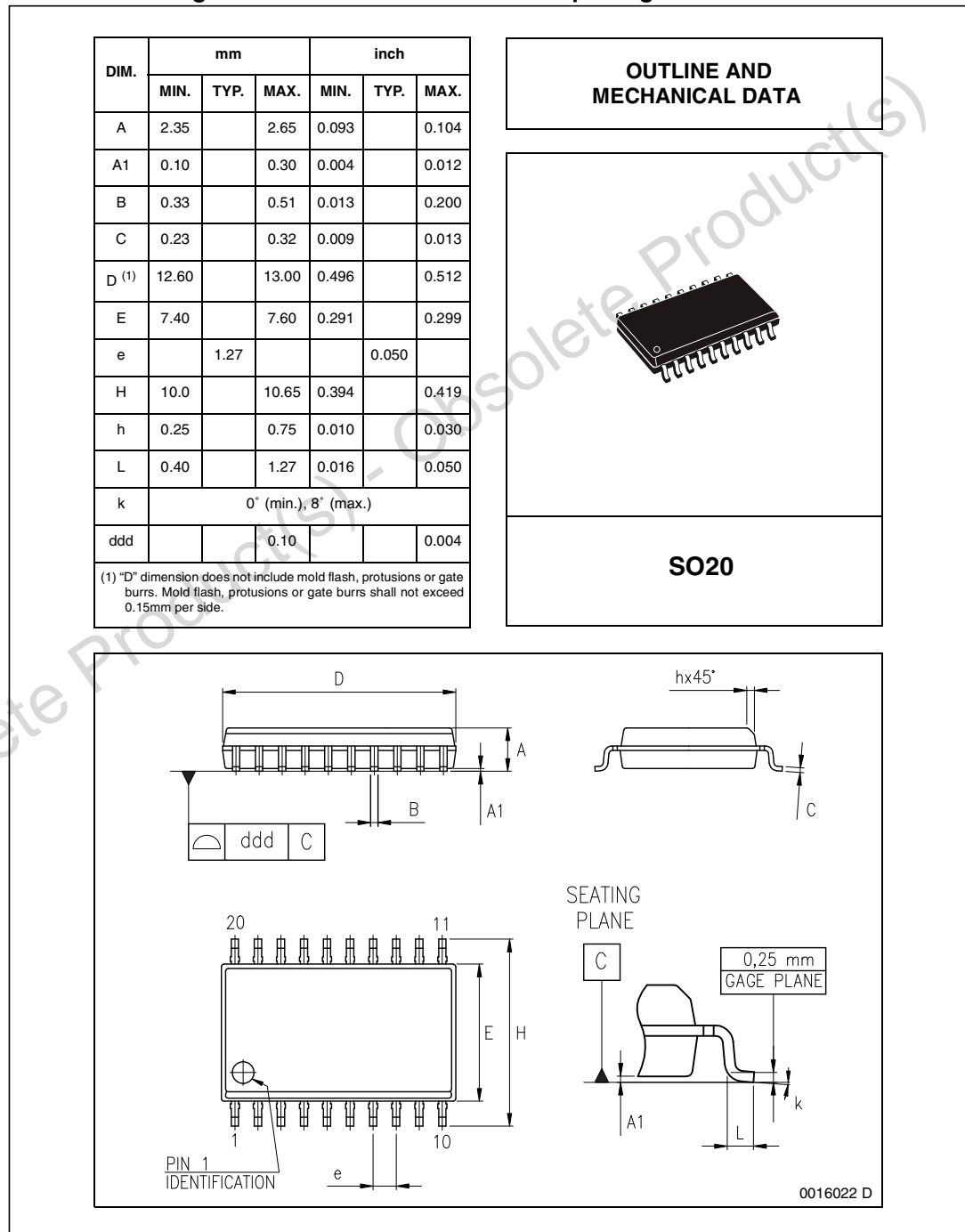

## 9 Revision history

Table 14. Document revision history

Date	Revision	Changes
03-Sep-2014	5	Removed DIP20 package option Updated <i>Table 1: Device summary</i> Revised document presentation along with minor textual updates and modification of title

Obsolete Product(s) - Obsolete Product(s)

**IMPORTANT NOTICE – PLEASE READ CAREFULLY**

STMicroelectronics NV and its subsidiaries ("ST") reserve the right to make changes, corrections, enhancements, modifications, and improvements to ST products and/or to this document at any time without notice. Purchasers should obtain the latest relevant information on ST products before placing orders. ST products are sold pursuant to ST's terms and conditions of sale in place at the time of order acknowledgement.

Purchasers are solely responsible for the choice, selection, and use of ST products and ST assumes no liability for application assistance or the design of Purchasers' products.

No license, express or implied, to any intellectual property right is granted by ST herein.

Resale of ST products with provisions different from the information set forth herein shall void any warranty granted by ST for such product.

ST and the ST logo are trademarks of ST. All other product or service names are the property of their respective owners.

Information in this document supersedes and replaces information previously supplied in any prior versions of this document.

© 2014 STMicroelectronics – All rights reserved