



2140 MHz Saw Filter

P/N: AM2140S175

Parameters Description	Minimum	Typical	Maximum
Center Frequency (Fo)	-	2140 MHz	-
Insertion Loss within 2110 ~ 2170 MHz	-	2.2 dB	3.5 dB
Source Impedance (single ended) ⁽¹⁾	-	50 Ω	-
Load Impedance (single ended) ⁽¹⁾	-	50 Ω	-
Operating Temperature Range	-30°C	-	+85°C
Amplitude Ripple within 2110 ~ 2170 MHz	-	0.9 dB _{p-p}	1.5 dB _{p-p}
Attenuation:			
D.C. ~ 500 MHz	25 dB	35 dB	-
500 ~ 2025 MHz	20 dB	30 dB	-
2025 ~ 2050 MHz	27 dB	37 dB	-
2230 ~ 2260 MHz	41 dB	51 dB	-
2490 ~ 2550 MHz	31 dB	41 dB	-
VSWR within 2110 ~ 2170 MHz	-	1.8	2.5
Maximum DC Voltage	-	-	7.5 V
Maximum Input Power	-	-	15 dBm
Package type & size	M		
Length x Width	3.0 x 3.0 mm ²		
Height	1.3 mm max		

Notes: (1) No Matching Network (Ref. Testing Environment Circuit as shown below).



2140 MHz Saw Filter

P/N: AM2140S175

Packing Dimensions:

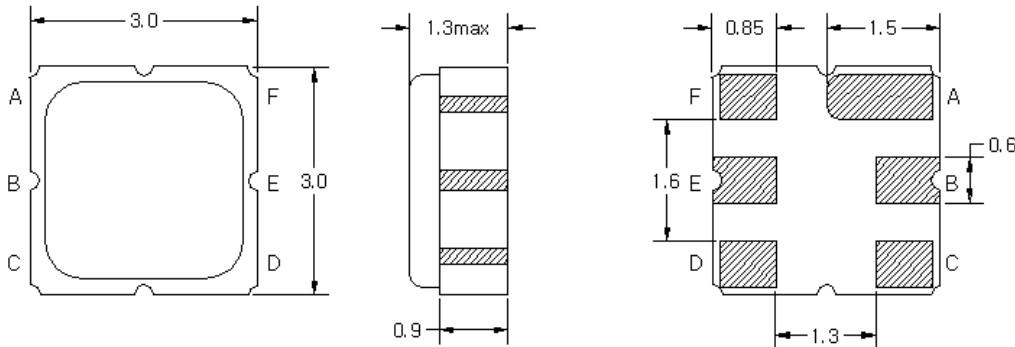

PIN Descriptions:
 IN – E, OUT - B,
 GROUND – A, C, D, F

Testing Environment:

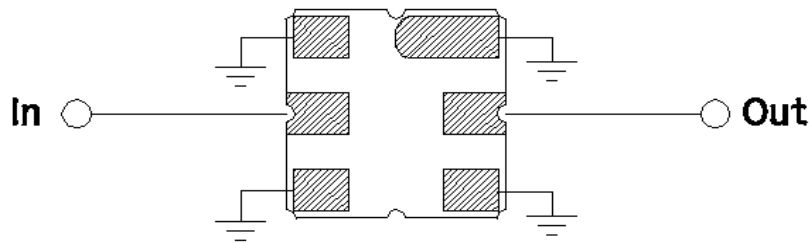

Source & Load Impedance: 50 Ω





2140 MHz Saw Filter

P/N: AM2140S175

Frequency Response:

VSWR

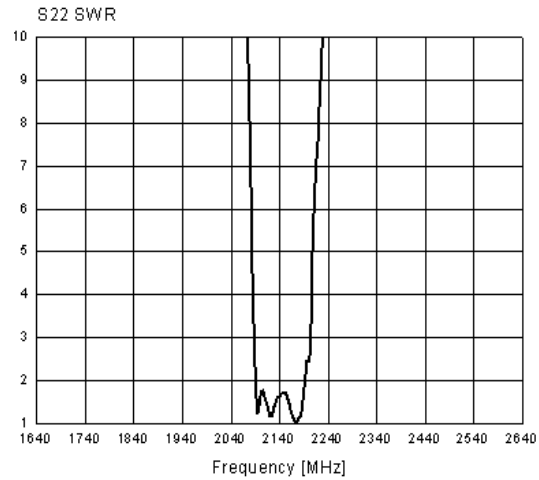
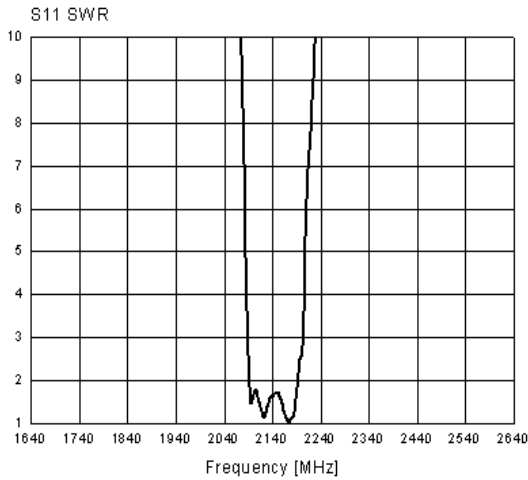

SMITH CHART

