

Rugged 20Mbps, 8 Channel Multi-Protocol Transceiver with Programmable DCE/DTE and Termination Resistors

FEATURES

- 20Mbps Differential Transmission Rates
- 15kV ESD Tolerance for Analog I/Os
- Internal Transceiver Termination Resistors for V.11/V.35
- Interface Modes:
 - RS-232 (V.28) – EIA-530 (V.10 & V.11)
 - X.21 (V.11) – EIA-530A (V.10 & V.11)
 - RS-449/V.36 – V.35
 - (V.10 & V.11)
- Software Selectable Protocols with 3-Bit Word
- Eight Drivers and Eight Receivers
- V.35/V.11 Receiver Termination Network Disable Option
- Internal Line or Digital Loopback Testing
- Adheres to NET1/NET2 and TBR-2 Requirements

Now Available in Lead Free Packaging

Refer to page 7 for pinout

- Easy Flow-Through Pinout
- +5V Only Operation
- Individual Driver/Receiver Enable/Disable Controls
- Operates in DTE or DCE Mode

APPLICATIONS

- Router
- Frame Relay
- CSU
- DSU
- PBX
- Secure Communication Terminals

DESCRIPTION

The SP508E is a monolithic device that supports eight (8) popular serial interface standards for Wide Area Network (WAN) connectivity. The SP508E is fabricated using a low power BiCMOS process technology, and incorporates an Exar regulated charge pump allowing +5V only operation. Exar's patented charge pump provides a regulated output of $\pm 5.8V$, which will provide enough voltage for compliant operation in all modes. Eight (8) drivers and eight (8) receivers can be configured via software for any of the above interface modes at any time. The SP508E requires no additional external components for compliant operation for all of the eight (8) modes of operation other than four capacitors used for the internal charge pump. All necessary termination is integrated within the SP508E and is switchable when V.35 drivers and V.35 receivers, or when V.11 receivers are used. The SP508E provides the controls and transceiver availability for operating as either a DTE or DCE.

Additional features with the SP508E include internal loopback that can be initiated in any of the operating modes by use of the LOOPBACK pin. While in loopback mode, receiver outputs are internally connected to driver inputs creating an internal signal path bypassing the serial communications controller for diagnostic testing. The SP508E also includes a latch enable pin with the driver and receiver address decoder. The internal V.11 or V.35 receiver termination can be switched off using a control pin (TERM_OFF) for monitoring applications. All eight (8) drivers and receivers in the SP508E include separate enable pins for added convenience. The SP508E is ideal for WAN serial ports in networking equipment such as routers, access concentrators, network muxes, DSU/CSU's, networking test equipment, and other access devices.

Applicable U.S. Patents-5,306,954; and others patents pending

ABSOLUTE MAXIMUM RATINGS

These are stress ratings only and functional operation of the device at these ratings or any other above those indicated in the operation sections of the specifications below is not implied. Exposure to absolute maximum rating conditions for extended periods of time may affect reliability.

V _{CC}	+7V
Input Voltages:	
Logic	-0.3V to (V _{CC} +0.5V)
Drivers.....	-0.3V to (V _{CC} +0.5V)
Receivers.....	±15.5V
Output Voltages:	
Logic	-0.3V to (V _{CC} +0.5V)
Drivers.....	-7.5V to +12.5V
Receivers.....	-0.3V to (V _{CC} +0.5V)
Storage Temperature.....	-65°C to +150°C
Power Dissipation.....	1520mW
(derate 19.0mW/°C above +70°C)	
Package Derating:	
θ _{JA}	52.7 °C/W
θ _{JC}	6.5 °C/W

STORAGE CONSIDERATIONS

Due to the relatively large package size, storage in a low humidity environment is preferred. Large high density plastic packages are moisture sensitive and should be stored in Dry Vapor Barrier Bags. Prior to usage, the parts should remain bagged and stored below 40°C and 60%RH. If the parts are removed from the bag, they should be used within 48 hours or stored in an environment at or below 20%RH. If the above conditions cannot be followed, the parts should be baked for four hours at 125°C in order to remove moisture prior to soldering. Exar ships the 100-pin LQFP in Dry Vapor Barrier Bags with a humidity indicator card and desiccant pack. The humidity indicator should be below 30%RH.

ELECTRICAL SPECIFICATIONS

T_A = -40°C to +85°C and V_{CC} = +4.75V to +5.25V unless otherwise noted. Typical values are for T_A = 25°C and V_{CC} = 5V.

PARAMETER	MIN.	TYP.	MAX.	UNITS	CONDITIONS
LOGIC INPUTS					
V _{IL}	2.0		0.8	Volts	
V _{IH}				Volts	
LOGIC OUTPUTS					
V _{OL}		2.4	0.4	Volts	I _{OUT} = -3.2mA
V _{OH}				Volts	I _{OUT} = 1.0mA
V.28 DRIVER					
DC Parameters					
Outputs					
Open Circuit Voltage			±15	Volts	per Figure 1
Loaded Voltage	±5.0		±15	Volts	per Figure 2
Short-Circuit Current			±100	mA	per Figure 4, V _{OUT} =0V
Power-Off Impedance	300			Ω	per Figure 5
AC Parameters					
Outputs					
Transition Time			1.5	μs	per Figure 6; +3V to -3V
Instantaneous Slew Rate			30	V/μs	per Figure 3
Propagation Delay					
t _{PHL}	0.5	1	5	μs	
t _{PLH}	0.5	1	5	μs	
Max. Transmission Rate	120	230		kbps	
V.28 RECEIVER					
DC Parameters					
Inputs					
Input Impedance	3		7	kΩ	per Figure 7
Open-Circuit Bias			+2.0	Volts	per Figure 8
HIGH Threshold		1.7	3.0	Volts	
LOW Threshold	0.8	1.2		Volts	
AC Parameters					
Propagation Delay					
t _{PHL}	50	100	500	ns	
t _{PLH}	50	100	500	ns	

ELECTRICAL SPECIFICATIONS

$T_A = -40^{\circ}\text{C}$ to $+85^{\circ}\text{C}$ and $V_{CC} = +4.75\text{V}$ to $+5.25\text{V}$ unless otherwise noted. Typical values are for $T_A = 25^{\circ}\text{C}$ and $V_{CC} = 5\text{V}$

PARAMETER	MIN.	TYP.	MAX.	UNITS	CONDITIONS
V.28 RECEIVER (cont) AC Parameters (cont.) Max. Transmission Rate	120	235		kbps	
V.10 DRIVER DC Parameters Outputs Open Circuit Voltage Test-Terminated Voltage Short-Circuit Current Power-Off Current AC Parameters Outputs Transition Time Propagation Delay t_{PHL} t_{PLH} Max. Transmission Rate	± 4.0 $0.9V_{OC}$		± 6.0 ± 150 ± 100 500 500 500 120	Volts Volts mA μA ns ns ns kbps	per Figure 9 per Figure 10 per Figure 11 per Figure 12 per Figure 13; 10% to 90%
V.10 RECEIVER DC Parameters Inputs Input Current Input Impedance Sensitivity AC Parameters Propagation Delay t_{PHL} t_{PLH} Max. Transmission Rate	-3.25 4		$+3.25$ ± 0.3 500 500 120	mA k Ω Volts ns ns kbps	per Figures 14 and 15
V.11 DRIVER DC Parameters Outputs Open Circuit Voltage Test Terminated Voltage Balance Offset Short-Circuit Current Power-Off Current AC Parameters Outputs Transition Time Propagation Delay t_{PHL} t_{PLH} Differential Skew ($ t_{phi} - t_{plh} $) Max. Transmission Rate Channel to Channel Skew	± 2.0 $0.5V_{OC}$		± 6.0 $0.67V_{OC}$ ± 0.4 $+3.0$ ± 150 ± 100 10 30 30 5 10 20 2	Volts Volts Volts Volts mA μA ns ns ns ns ns Mbps ns	per Figure 16 per Figure 17 per Figure 17 per Figure 17 per Figure 18 per Figure 19 per Fig. 21 and 36; 10% to 90% Using $C_L = 50\text{pF}$; per Figures 33 and 36 per Figures 33 and 36 per Figures 33 and 36
V.11 RECEIVER DC Parameters Inputs Common Mode Range Sensitivity	-7		$+7$ ± 0.2	Volts Volts	

ELECTRICAL SPECIFICATIONS

$T_A = -40^{\circ}\text{C}$ to $+85^{\circ}\text{C}$ and $V_{CC} = +4.75\text{V}$ to $+5.25\text{V}$ unless otherwise noted. Typical values are for $T_A = 25^{\circ}\text{C}$ and $V_{CC} = 5\text{V}$

PARAMETER	MIN.	TYP.	MAX.	UNITS	CONDITIONS
V.11 RECEIVER (cont)					
DC Parameters (cont.)					
Input Current	-3.25		±3.25	mA	per Figure 20 and 22; power on or off per Figure 23 and 24
Current w/ 100Ω Termination			±60.75	mA	
Input Impedance	4			kΩ	
AC Parameters					
Propagation Delay					Using $C_L = 50\text{pF}$; per Figures 33 and 38 per Figures 33 and 38 per Figure 33
t_{PHL}		30	85	ns	
t_{PLH}		30	85	ns	
Skew($(t_{pHL} - t_{pLH})$)		5	10	ns	
Max. Transmission Rate	20			Mbps	
Channel to Channel Skew		2		ns	
V.35 DRIVER					
DC Parameters					
Outputs					
Test Terminated Voltage	±0.44		±0.66	Volts	per Figure 25
Offset			±0.6	Volts	
Output Overshoot	-0.2V _{ST}		+0.2V _{ST}	Volts	per Figure 25; V_{ST} = Steady state value per Figure 27; $Z_S = V_2/V_1 \times 50$
Source Impedance	50		150	Ω	
Short-Circuit Impedance	135		165	Ω	per Figure 28
AC Parameters					
Outputs					
Transition Time		7	20	ns	per Figure 29; 10% to 90%
Propagation Delay					per Figure 33 and 36; $C_L = 20\text{pF}$ per Figure 33 and 36; $C_L = 20\text{pF}$ per Figure 33 and 36; $C_L = 20\text{pF}$
t_{PHL}		30	85	ns	
t_{PLH}		30	85	ns	
Differential Skew		5	10	ns	
($(t_{pHL} - t_{pLH})$)					
Max. Transmission Rate	20			Mbps	
Channel to Channel Skew		2		ns	
V.35 RECEIVER					
DC Parameters					
Inputs					
Sensitivity		±50	±200	mV	per Figure 30; $Z_S = V_2/V_1 \times 50\Omega$ per Figure 31
Source Impedance	90		110	Ω	
Short-Circuit Impedance	135		165	Ω	
AC Parameters					
Propagation Delay					per Figure 33 and 38; $C_L = 20\text{pF}$ per Figure 33 and 38; $C_L = 20\text{pF}$ per Figure 33; $C_L = 20\text{pF}$
t_{PHL}		30	85	ns	
t_{PLH}		30	85	ns	
Skew($(t_{pHL} - t_{pLH})$)		5	10	ns	
Max. Transmission Rate	20			Mbps	
Channel to Channel Skew		2		ns	
TRANSCEIVER LEAKAGE CURRENT					
Driver Output 3-State Current		500		μA	per Figure 32; Drivers disabled T_X & R_X disabled, 0.4V - V_O - 2.4V
Rcvr Output 3-State Current		1	10	μA	
POWER REQUIREMENTS					
V_{CC}	4.75	5.00	5.25	Volts	All I_{CC} values are with $V_{CC} = +5\text{V}$ $f_{IN} = 120\text{kbps}$; Drivers active & loaded $f_{IN} = 10\text{Mbps}$; Drivers active & loaded $f_{IN} = 10\text{Mbps}$; Drivers active & loaded V.35 @ $f_{IN} = 10\text{Mbps}$; V.28 @ 20kbps $f_{IN} = 10\text{Mbps}$; Drivers active & loaded
I_{CC} (Shutdown Mode)		200		μA	
(V.28/RS-232)		95		mA	
(V.11/RS-422)		230		mA	
(EIA-530 & RS-449)		270		mA	
(V.35)		170		mA	
(EIA-530A)		200		mA	

OTHER AC CHARACTERISTICS

$T_A = -40^{\circ}\text{C}$ to $+85^{\circ}\text{C}$ and $V_{CC} = +4.75\text{V}$ to $+5.25\text{V}$ unless otherwise noted. Typical values are for $T_A = 25\text{C}$ and $V_{CC} = 5\text{V}$.

PARAMETER	MIN.	TYP.	MAX.	UNITS	CONDITIONS
DRIVER DELAY TIME BETWEEN ACTIVE MODE AND TRI-STATE MODE					
RS-232/V.28					
t_{PZL}^1 : Tri-state to Output LOW		0.11	5.0	μs	$C_L = 100\text{pF}$, Fig. 34 & 40; S_2 closed
t_{PHZ}^1 : Tri-state to Output HIGH		0.11	2.0	μs	$C_L = 100\text{pF}$, Fig. 34 & 40; S_2 closed
t_{PLZ}^2 : Output LOW to Tri-state		0.05	2.0	μs	$C_L = 100\text{pF}$, Fig. 34 & 40; S_2 closed
t_{PHZ}^2 : Output HIGH to Tri-state		0.05	2.0	μs	$C_L = 100\text{pF}$, Fig. 34 & 40; S_2 closed
RS-423/V.10					
t_{PZL}^1 : Tri-state to Output LOW		0.07	2.0	μs	$C_L = 100\text{pF}$, Fig. 34 & 40; S_2 closed
t_{PHZ}^1 : Tri-state to Output HIGH		0.05	2.0	μs	$C_L = 100\text{pF}$, Fig. 34 & 40; S_2 closed
t_{PLZ}^2 : Output LOW to Tri-state		0.55	2.0	μs	$C_L = 100\text{pF}$, Fig. 34 & 40; S_2 closed
t_{PHZ}^2 : Output HIGH to Tri-state		0.12	2.0	μs	$C_L = 100\text{pF}$, Fig. 34 & 40; S_2 closed
RS-422/V.11					
t_{PZL}^1 : Tri-state to Output LOW		0.04	10.0	μs	$C_L = 100\text{pF}$, Fig. 34 & 37; S_1 closed
t_{PHZ}^1 : Tri-state to Output HIGH		0.05	2.0	μs	$C_L = 100\text{pF}$, Fig. 34 & 37; S_2 closed
t_{PLZ}^2 : Output LOW to Tri-state		0.03	2.0	μs	$C_L = 15\text{pF}$, Fig. 34 & 37; S_1 closed
t_{PHZ}^2 : Output HIGH to Tri-state		0.11	2.0	μs	$C_L = 15\text{pF}$, Fig. 34 & 37; S_2 closed
V.35					
t_{PZL}^1 : Tri-state to Output LOW		0.85	10.0	μs	$C_L = 100\text{pF}$, Fig. 34 & 37; S_1 closed
t_{PHZ}^1 : Tri-state to Output HIGH		0.36	2.0	μs	$C_L = 100\text{pF}$, Fig. 34 & 37; S_2 closed
t_{PLZ}^2 : Output LOW to Tri-state		0.06	2.0	μs	$C_L = 15\text{pF}$, Fig. 34 & 37; S_1 closed
t_{PHZ}^2 : Output HIGH to Tri-state		0.05	2.0	μs	$C_L = 15\text{pF}$, Fig. 34 & 37; S_2 closed
RECEIVER DELAY TIME BETWEEN ACTIVE MODE AND TRI-STATE MODE					
RS-232/V.28					
t_{PZL}^1 : Tri-state to Output LOW		0.05	2.0	μs	$C_L = 100\text{pF}$, Fig. 35 & 40; S_1 closed
t_{PHZ}^1 : Tri-state to Output HIGH		0.05	2.0	μs	$C_L = 100\text{pF}$, Fig. 35 & 40; S_2 closed
t_{PLZ}^2 : Output LOW to Tri-state		0.65	2.0	μs	$C_L = 100\text{pF}$, Fig. 35 & 40; S_2 closed
t_{PHZ}^2 : Output HIGH to Tri-state		0.65	2.0	μs	$C_L = 100\text{pF}$, Fig. 35 & 40; S_2 closed
RS-423/V.10					
t_{PZL}^1 : Tri-state to Output LOW		0.04	2.0	μs	$C_L = 100\text{pF}$, Fig. 35 & 40; S_1 closed
t_{PHZ}^1 : Tri-state to Output HIGH		0.03	2.0	μs	$C_L = 100\text{pF}$, Fig. 35 & 40; S_2 closed
t_{PLZ}^2 : Output LOW to Tri-state		0.03	2.0	μs	$C_L = 100\text{pF}$, Fig. 35 & 40; S_2 closed
t_{PHZ}^2 : Output HIGH to Tri-state		0.03	2.0	μs	$C_L = 100\text{pF}$, Fig. 35 & 40; S_2 closed

OTHER AC CHARACTERISTICS (Continued)

$T_A = -40^\circ\text{C}$ to $+85^\circ\text{C}$ and $V_{CC} = +4.75\text{V}$ to $+5.25\text{V}$ unless otherwise noted. Typical values are for $T_A = 25^\circ\text{C}$ and $V_{CC} = 5\text{V}$

PARAMETER	MIN.	TYP.	MAX.	UNITS	CONDITIONS
RS-422/V.11					
t_{PZL} : Tri-state to Output LOW		0.04	2.0	μs	$C_L = 100\text{pF}$, Fig. 35 & 39; S_1 closed
t_{PZH} : Tri-state to Output HIGH		0.03	2.0	μs	$C_L = 100\text{pF}$, Fig. 35 & 39; S_2 closed
t_{PLZ} : Output LOW to Tri-state		0.03	2.0	μs	$C_L = 15\text{pF}$, Fig. 35 & 39; S_1 closed
t_{PHZ} : Output HIGH to Tri-state		0.03	2.0	μs	$C_L = 15\text{pF}$, Fig. 35 & 39; S_2 close
V.35					
t_{PZL} : Tri-state to Output LOW		0.04	2.0	μs	$C_L = 100\text{pF}$, Fig. 35 & 39; S_1 closed
t_{PZH} : Tri-state to Output HIGH		0.03	2.0	μs	$C_L = 100\text{pF}$, Fig. 35 & 39; S_2 closed
t_{PLZ} : Output LOW to Tri-state		0.03	2.0	μs	$C_L = 15\text{pF}$, Fig. 35 & 39; S_1 closed
t_{PHZ} : Output HIGH to Tri-state		0.03	2.0	μs	$C_L = 15\text{pF}$, Fig. 35 & 39; S_2 closed
TRANSCEIVER TO TRANSCEIVER SKEW					(per Figures 32, 33, 36, 38)
RS-232 Driver		100		ns	$[(t_{\text{phl}})_{TX1} - (t_{\text{phl}})_{TXn}]$
		100		ns	$[(t_{\text{plh}})_{TX1} - (t_{\text{plh}})_{TXn}]$
RS-232 Receiver		20		ns	$[(t_{\text{phl}})_{RX1} - (t_{\text{phl}})_{RXn}]$
		20		ns	$[(t_{\text{plh}})_{RX1} - (t_{\text{plh}})_{RXn}]$
RS-422 Driver		2		ns	$[(t_{\text{phl}})_{TX1} - (t_{\text{phl}})_{TXn}]$
		2		ns	$[(t_{\text{plh}})_{TX1} - (t_{\text{plh}})_{TXn}]$
RS-422 Receiver		2		ns	$[(t_{\text{phl}})_{RX1} - (t_{\text{phl}})_{RXn}]$
		2		ns	$[(t_{\text{plh}})_{RX1} - (t_{\text{plh}})_{RXn}]$
RS-423 Driver		2		ns	$[(t_{\text{phl}})_{TX2} - (t_{\text{phl}})_{TXn}]$
		2		ns	$[(t_{\text{plh}})_{TX2} - (t_{\text{plh}})_{TXn}]$
RS-423 Receiver		2		ns	$[(t_{\text{phl}})_{RX2} - (t_{\text{phl}})_{RXn}]$
		2		ns	$[(t_{\text{plh}})_{RX2} - (t_{\text{plh}})_{RXn}]$
V.35 Driver		2		ns	$[(t_{\text{phl}})_{TX1} - (t_{\text{phl}})_{TXn}]$
V.35 Receiver		2		ns	$[(t_{\text{plh}})_{TX1} - (t_{\text{plh}})_{TXn}]$
		2		ns	$[(t_{\text{phl}})_{RX1} - (t_{\text{phl}})_{RXn}]$
		2		ns	$[(t_{\text{plh}})_{RX1} - (t_{\text{plh}})_{RXn}]$

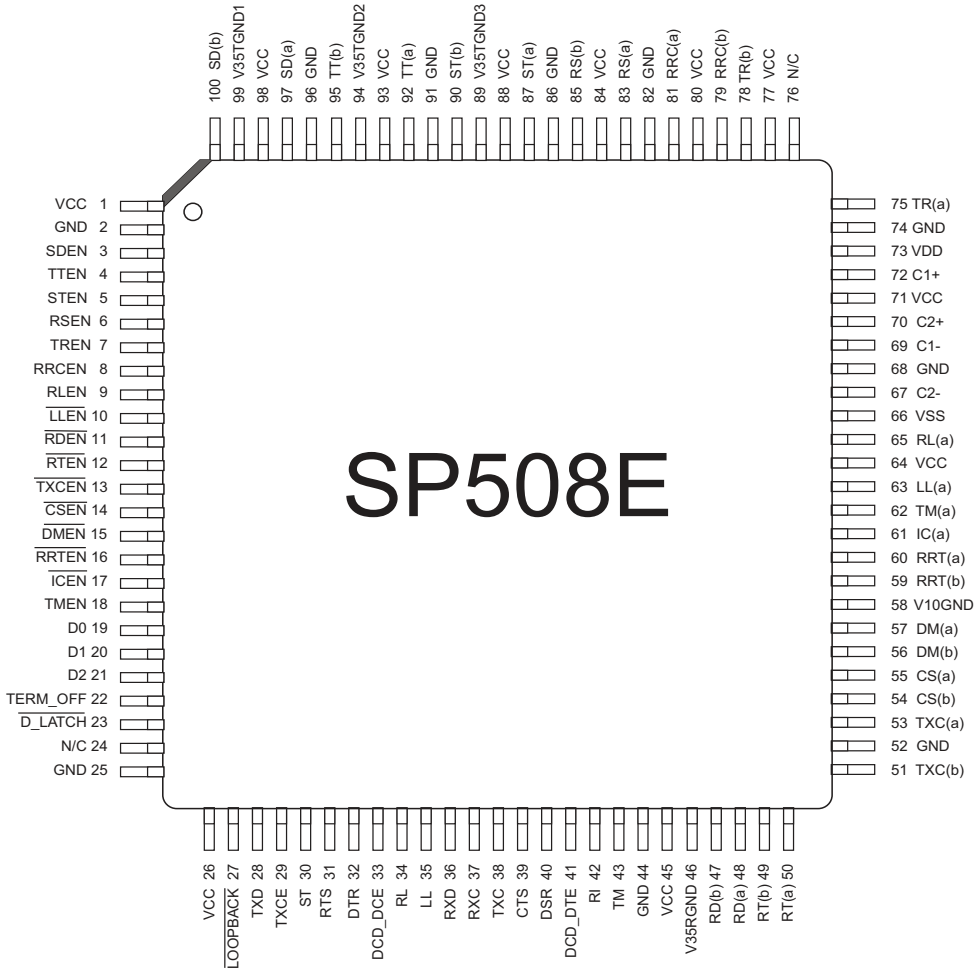

PIN DESCRIPTION

Pin Number	Pin Name	Description	Pin Number	Pin Name	Description
1	VCC	5V Power Supply Input	51	TxC(b)	TxC Non-Inverting Input
2	GND	Signal Ground	52	GND	Signal Ground
3	SDEN	TxD Driver Enable Input	53	TxC(a)	TxC Inverting Input
4	TTEN	TxCE Driver Enable Input	54	CS(b)	CTS Non-Inverting Input
5	STEN	ST Driver Enable Input	55	CS(a)	CTS Inverting Input
6	RSEN	RTS Driver Enable Input	56	DM(b)	DSR Non-Inverting Input
7	TREN	DTR Driver Enable Input	57	DM(a)	DSR Inverting Input
8	RRCEN	DCD Driver Enable Input	58	GNDV10	V.10 Rx Reference Node
9	RLEN	RL Driver Enable Input	59	RRT(b)	DCD _{DTE} Non-Inverting Input
10	LLEN#	LL Driver Enable Input	60	RRT(a)	DCD _{DTE} Inverting Input
11	RDEN#	RxD Receiver Enable Input	61	IC	RI Receiver Input
12	RTEN#	RxC Receiver Enable Input	62	TM(a)	TM Receiver Input
13	TxCEN#	TxC Receiver Enable Input	63	LL(a)	LL Driver Output
14	CSEN#	CTS Receiver Enable Input	64	VCC	Power Supply Input
15	DMEN#	DSR Receiver Enable Input	65	RL(a)	RL Driver Output
16	RRTEN#	DCD _{DTE} Receiver Enable Input	66	VSS1	-2xVCC Charge Pump Output
17	ICEN#	RI Receiver Enable Input	67	C2N	Charge Pump Capacitor
18	TMEN	TM Receiver Enable Input	68	GND	Signal Ground
19	D0	Mode Select Input	69	C1N	Charge Pump Capacitor
20	D1	Mode Select Input	70	C2P	Charge Pump Capacitor
21	D2	Mode Select Input	71	VCC	Power Supply Input
22	TERM_OFF	Termination Disable Input	72	C1P	Charge Pump Capacitor
23	D_LATCH#	Decoder Latch Input	73	VDD	2xVCC Charge Pump Output
24	NC	No Connect	74	GND	Signal Ground
25	GND	Signal Ground	75	TR(a)	DTR Inverting Output
26	VCC	5V Power Supply Input	76	NC	No Connect
27	LOOPBACK#	Loopback Mode Enable Input	77	VCC	Power Supply Input
28	TxD	TxD Driver TTL Input	78	TR(b)	DTR Non-Inverting Output
29	TxCE	TxCE Driver TTL Input	79	RRC(b)	DCD Non-Inverting Output
30	ST	ST Driver TTL Input	80	VCC	Power Supply Input
31	RTS	RTS Driver TTL Input	81	RRC(a)	DCD Inverting Output
32	DTR	DTR Driver TTL Input	82	GND	Signal Ground
33	DCD_DCE	DCD _{DCE} Driver TTL Input	83	RS(a)	RTS Inverting Output
34	RL	RL Driver TTL Input	84	VCC	Power Supply Input
35	LL	LL Driver TTL Input	85	RS(b)	RTS Non-Inverting Output
36	RxD	RxD Receiver TTL Output	86	GND	Signal Ground
37	RxC	RxC Receiver TTL Output	87	ST(a)	ST Inverting Output
38	TxC	TxC Receiver TTL Output	88	VCC	Power Supply Input
39	CTS	CTS Receiver TTL Output	89	V35TGND3	ST Termination Reference
40	DSR	DSR Receiver TTL Output	90	ST(b)	ST Non-Inverting Output
41	DCD_DTE	DCD _{DTE} Receiver TTL Output	91	GND	Signal Ground
42	RI	RI Receiver TTL Output	92	TT(a)	TxCE Inverting Output
43	TM	TM Receiver TTL Output	93	VCC	5V Power Supply Input
44	GND	Signal Ground	94	V35TGND2	ST Termination Reference
45	VCC	Power Supply Input	95	TT(b)	TxCE Non-Inverting Output
46	V35RGND	Receiver Termination Reference	96	GND	Signal Ground
47	RD(b)	RxD Non-Inverting Input	97	SD(a)	TxD Inverting Output
48	RD(a)	RxD Inverting Input	98	VCC	5V Power Supply Input
49	RT(b)	RxC Non-Inverting Input	99	V35TGND1	ST Termination Reference
50	RT(a)	RxC Inverting Input	100	SD(b)	TxD Non-Inverting Output

SP508E Driver Table

Driver Output Pin	V.35 Mode	EIA-530 Mode	RS-232 Mode (V.28)	EIA-530A Mode	RS-449 Mode (V.36)	X.21 Mode (V.11)	Shutdown	Suggested Signal
MODE (D0, D1, D2)	001	010	011	100	101	110	111	
T ₁ OUT(a)	V.35	V.11	V.28	V.11	V.11	V.11	High-Z	TxD(a)
T ₁ OUT(b)	V.35	V.11	High-Z	V.11	V.11	V.11	High-Z	TxD(b)
T ₂ OUT(a)	V.35	V.11	V.28	V.11	V.11	V.11	High-Z	TxCE(a)
T ₂ OUT(b)	V.35	V.11	High-Z	V.11	V.11	V.11	High-Z	TxCE(b)
T ₃ OUT(a)	V.35	V.11	V.28	V.11	V.11	V.11	High-Z	TxC_DCE(a)
T ₃ OUT(b)	V.35	V.11	High-Z	V.11	V.11	V.11	High-Z	TxC_DCE(b)
T ₄ OUT(a)	V.28	V.11	V.28	V.11	V.11	V.11	High-Z	RTS(a)
T ₄ OUT(b)	High-Z	V.11	High-Z	V.11	V.11	V.11	High-Z	RTS(b)
T ₅ OUT(a)	V.28	V.11	V.28	V.10	V.11	V.11	High-Z	DTR(a)
T ₅ OUT(b)	High-Z	V.11	High-Z	High-Z	V.11	V.11	High-Z	DTR(b)
T ₆ OUT(a)	V.28	V.11	V.28	V.11	V.11	V.11	High-Z	DCD_DCE(a)
T ₆ OUT(b)	High-Z	V.11	High-Z	V.11	V.11	V.11	High-Z	DCD_DCE(b)
T ₇ OUT(a)	V.28	V.10	V.28	V.10	V.10	High-Z	High-Z	RL
T ₈ OUT(a)	V.28	V.10	V.28	V.10	V.10	High-Z	High-Z	LL

Table 1. Driver Mode Selection

SP508E Receiver Table

Receiver Input Pin	V.35 Mode	EIA-530 Mode	RS-232 Mode (V.28)	EIA-530A Mode	RS-449 Mode (V.36)	X.21 Mode (V.11)	Shutdown	Suggested Signal
MODE (D0, D1, D2)	001	010	011	100	101	110	111	
R ₁ IN(a)	V.35	V.11	V.28	V.11	V.11	V.11	High-Z	RxD(a)
R ₁ IN(b)	V.35	V.11	High-Z	V.11	V.11	V.11	High-Z	RxD(b)
R ₂ IN(a)	V.35	V.11	V.28	V.11	V.11	V.11	High-Z	RxC(a)
R ₂ IN(b)	V.35	V.11	High-Z	V.11	V.11	V.11	High-Z	RxC(b)
R ₃ IN(a)	V.35	V.11	V.28	V.11	V.11	V.11	High-Z	TxC_DTE(a)
R ₃ IN(b)	V.35	V.11	High-Z	V.11	V.11	V.11	High-Z	TxC_DTE(b)
R ₄ IN(a)	V.28	V.11	V.28	V.11	V.11	V.11	High-Z	CTS(a)
R ₄ IN(b)	High-Z	V.11	High-Z	V.11	V.11	V.11	High-Z	CTS(b)
R ₅ IN(a)	V.28	V.11	V.28	V.10	V.11	V.11	High-Z	DSR(a)
R ₅ IN(b)	High-Z	V.11	High-Z	High-Z	V.11	V.11	High-Z	DSR(b)
R ₆ IN(a)	V.28	V.11	V.28	V.11	V.11	V.11	High-Z	DCD_DTE(a)
R ₆ IN(b)	High-Z	V.11	High-Z	V.11	V.11	V.11	High-Z	DCD_DTE(b)
R ₇ IN(a)	V.28	V.10	V.28	V.10	V.10	High-Z	High-Z	RI
R ₈ IN(a)	V.28	V.10	V.28	V.10	V.10	High-Z	High-Z	TM

Table 2. Receiver Mode Selection

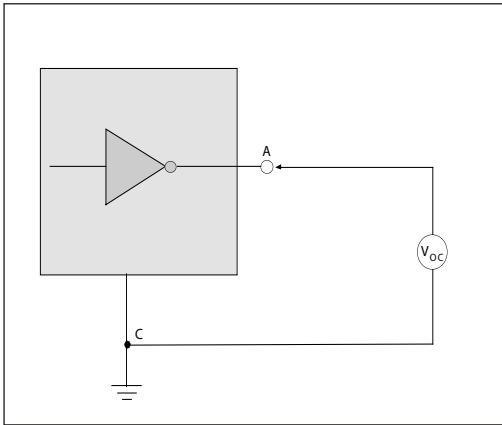

Figure 1. V.28 Driver Output Open Circuit Voltage

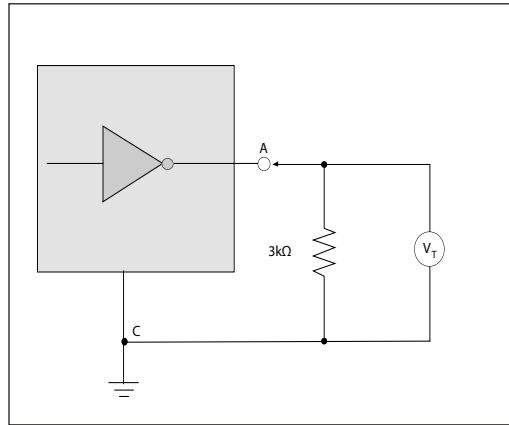

Figure 2. V.28 Driver Output Loaded Voltage

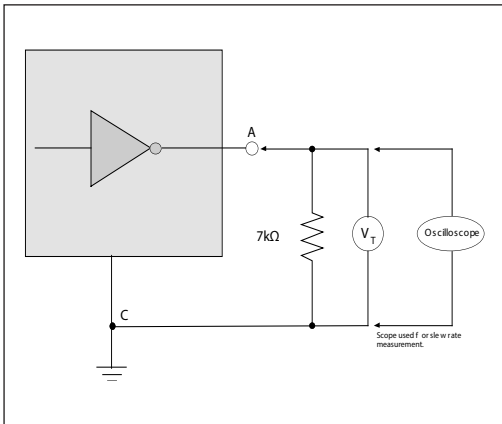

Figure 3. V.28 Driver Output Slew Rate

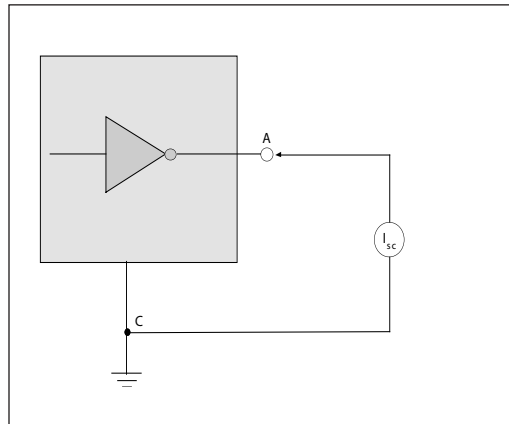

Figure 4. V.28 Driver Output Short-Circuit Current

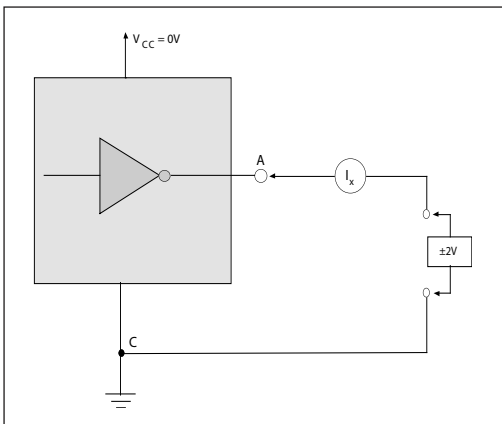

Figure 5. V.28 Driver Output Power-Off Impedance

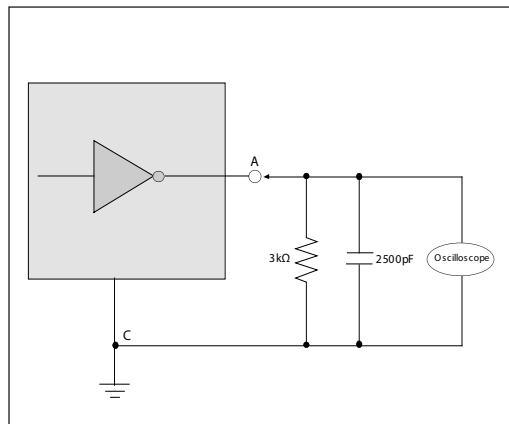

Figure 6. V.28 Driver Output Rise/Fall Times

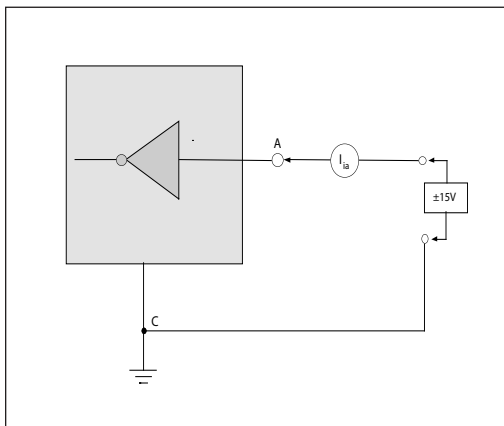

Figure 7. V.28 Receiver Input Impedance

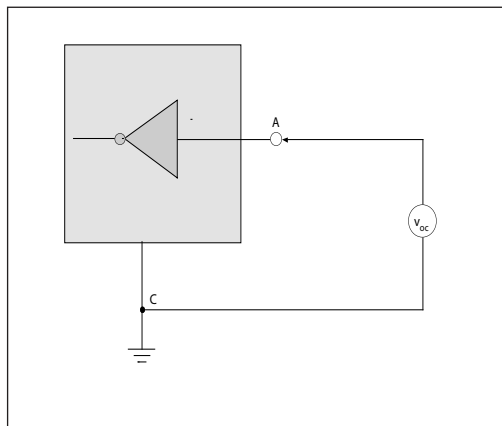

Figure 8. V.28 Receiver Input Open Circuit Bias

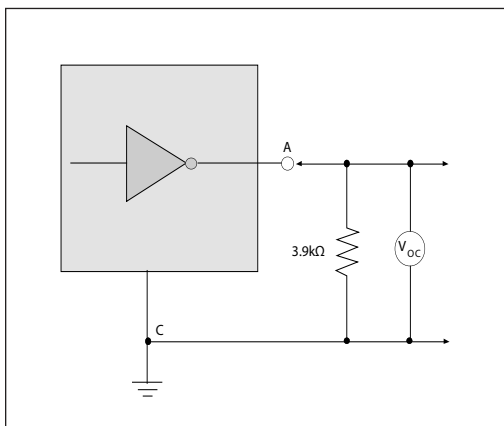

Figure 9. V.10 Driver Output Open-Circuit Voltage

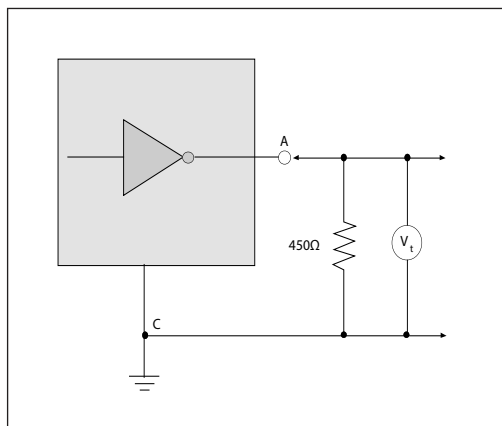

Figure 10. V.10 Driver Output Test Terminated Volt-

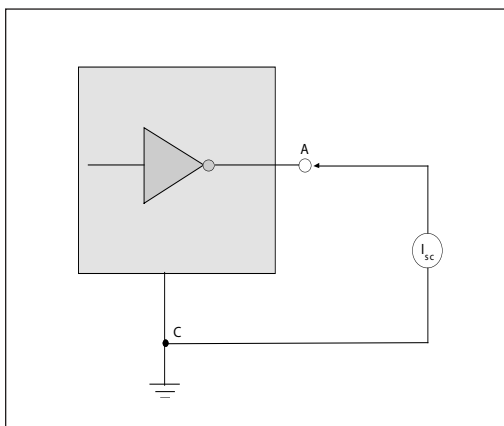

Figure 11. V.10 Driver Output Short-Circuit Current

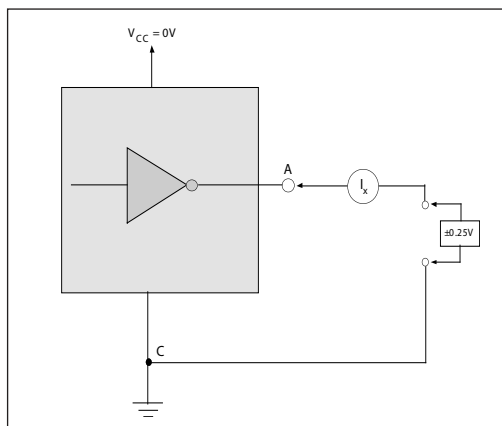

Figure 12. V.10 Driver Output Power-Off Current

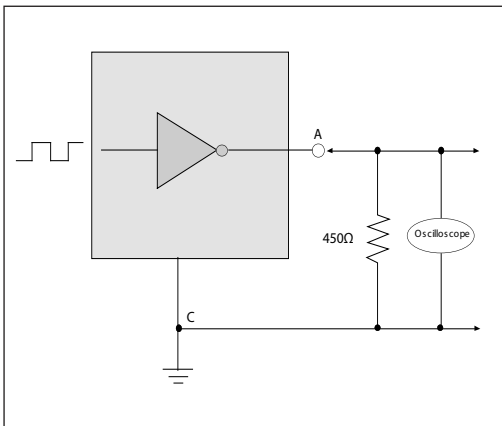

Figure 13. V.10 Driver Output Transition Time

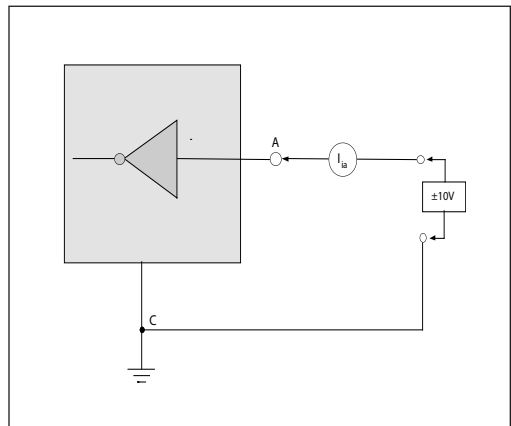

Figure 14. V.10 Receiver Input Current

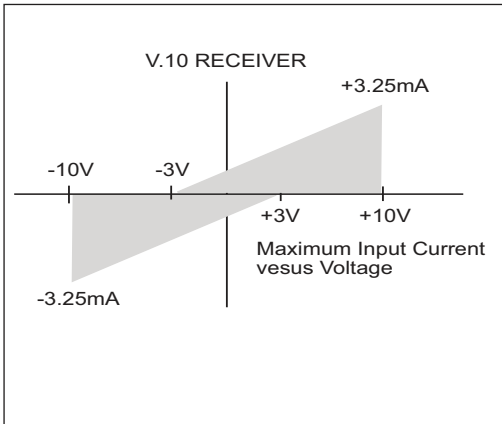

Figure 15. V.10 Receiver Input IV Graph

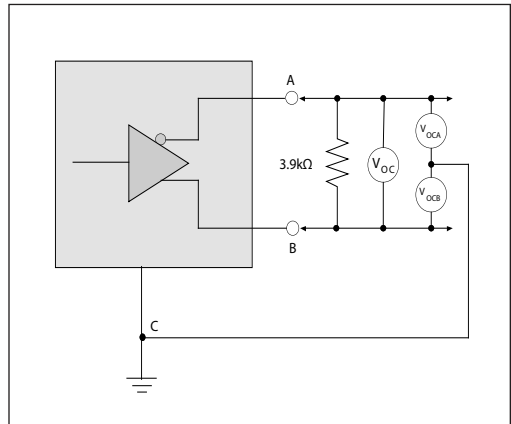

Figure 16. V.11 Driver Output Open-Circuit Voltage

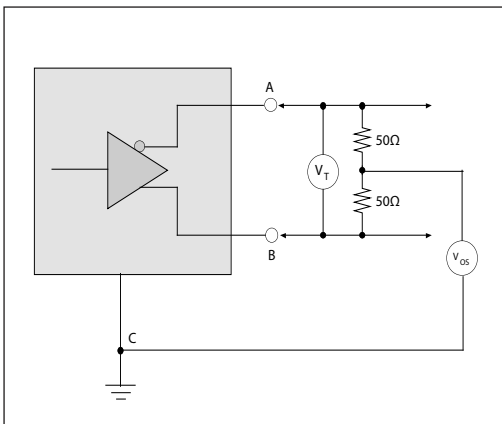

Figure 17. V.11 Driver Output Test Terminated Voltage

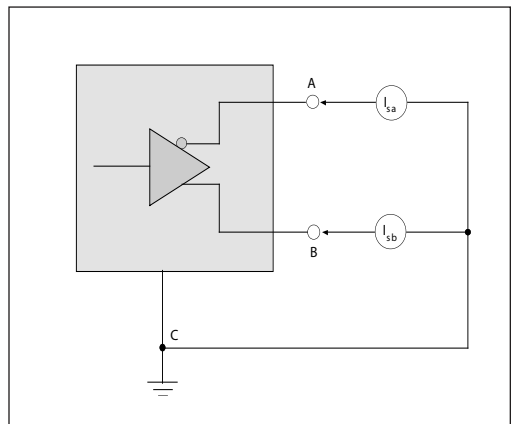

Figure 18. V.11 Driver Output Short-Circuit Current

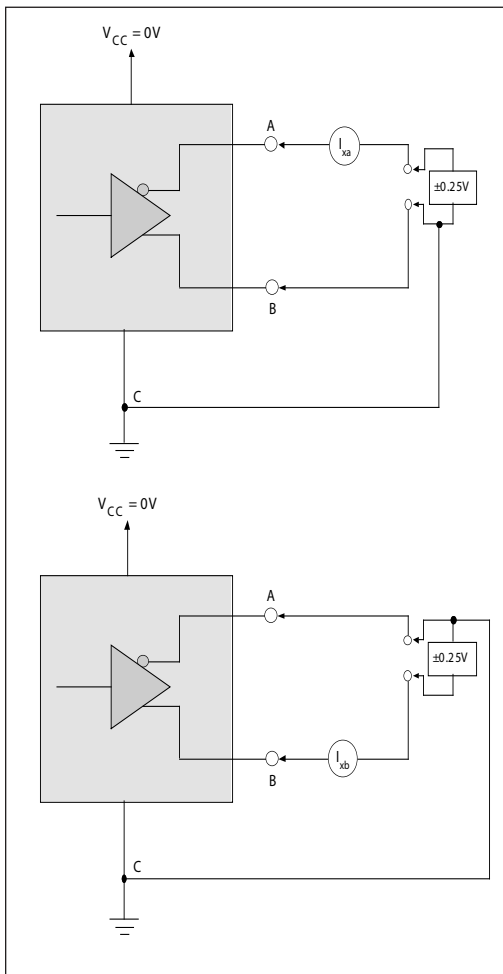

Figure 19. V.11 Driver Output Power-Off Current

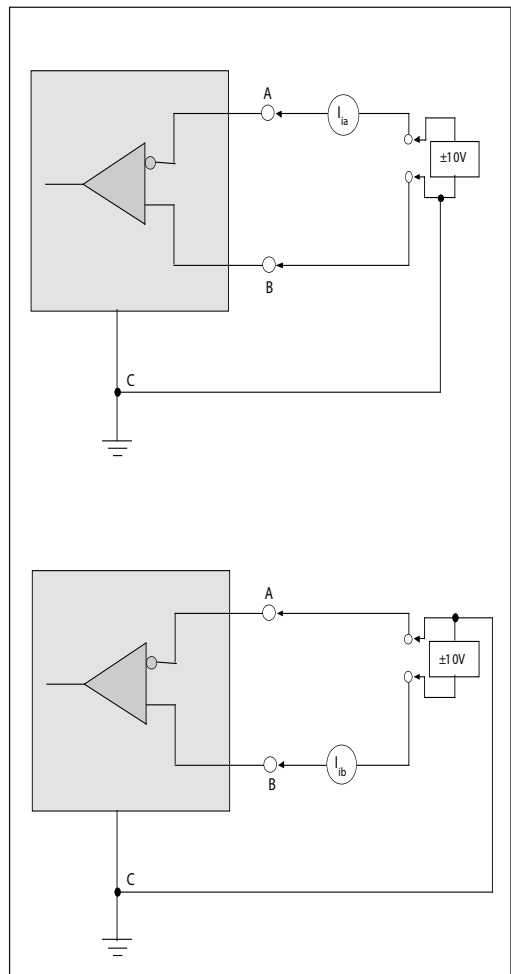

Figure 20. V.11 Receiver Input Current

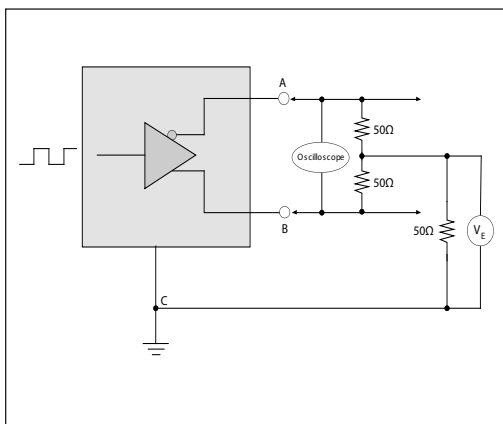

Figure 21. V.11 Driver Output Rise/Fall Time

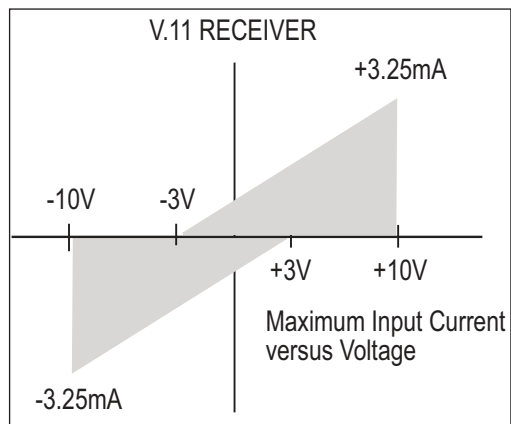

Figure 22. V.11 Receiver Input IV Graph

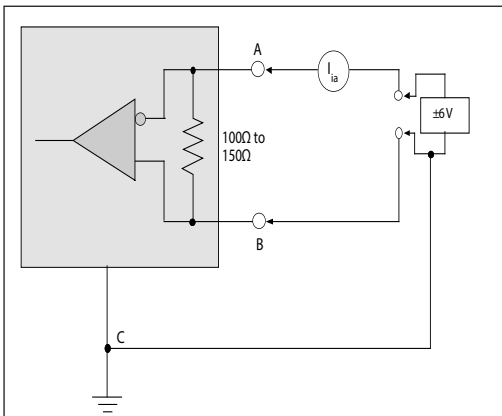

Figure 23. V.11 Receiver Input Current w/ Termination

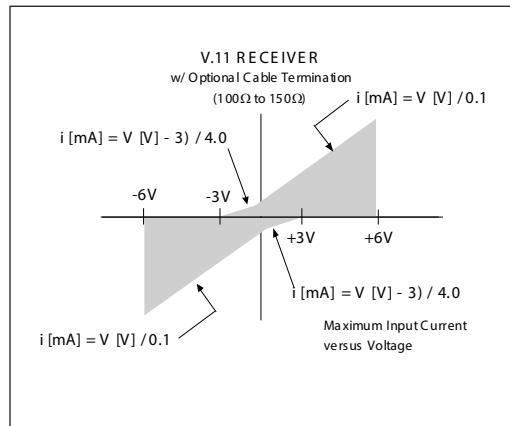
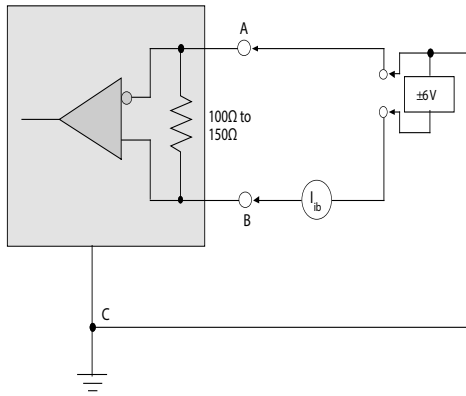

Figure 24. V.11 Receiver Input Graph w/ Termination

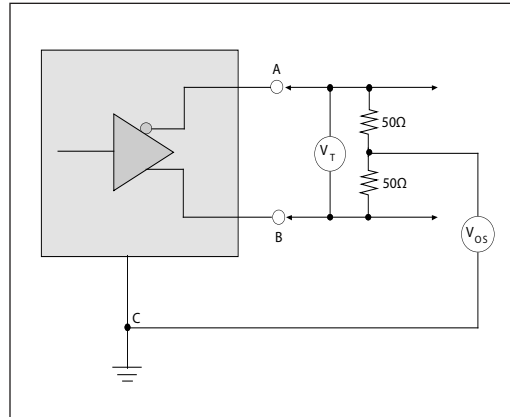

Figure 25. V.35 Driver Output Test Terminated Voltage

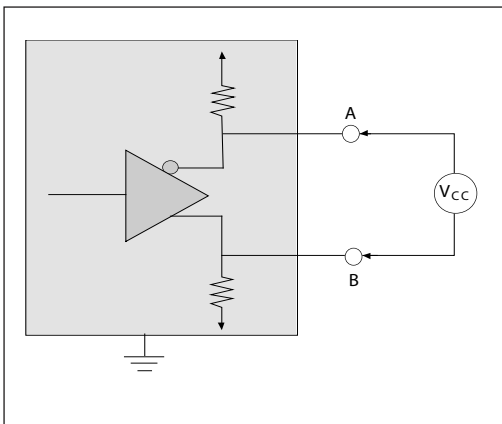

Figure 26. V.35 Driver Output Offset Voltage

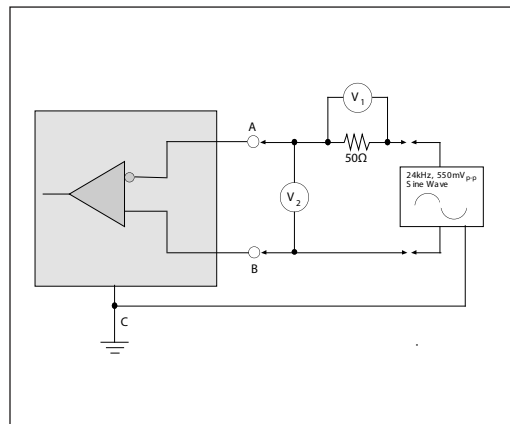

Figure 27. V.35 Driver Output Source Impedance

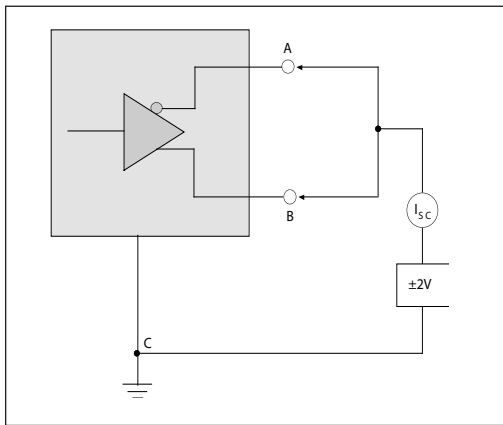

Figure 28. V.35 Driver Output Short-Circuit Impedance

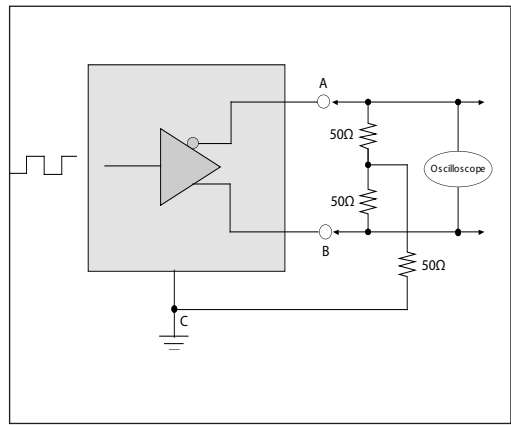

Figure 29. V.35 Driver Output Rise/Fall Time

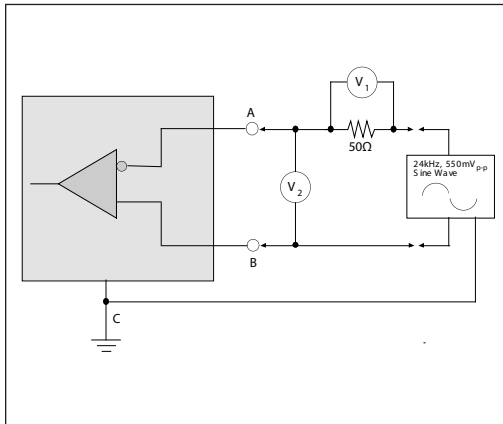

Figure 30. V.35 Receiver Input Source Impedance

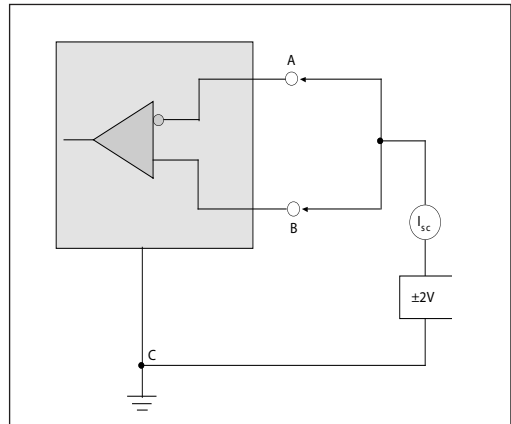

Figure 31. V.35 Receiver Input Short-Circuit Impedance

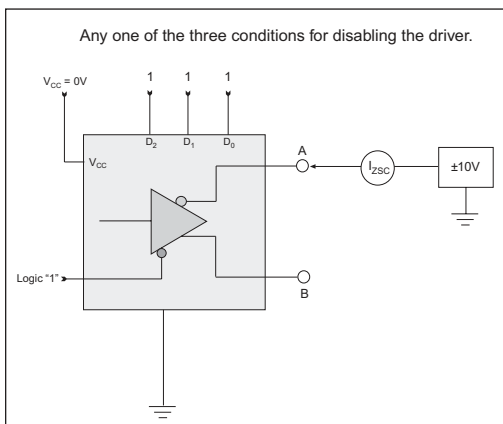

Figure 32. Driver Output Leakage Current Test

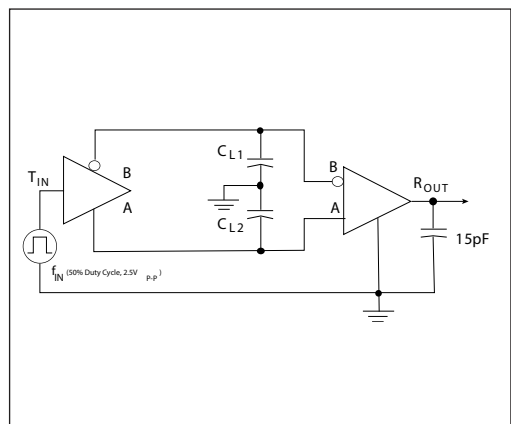

Figure 33. Driver/Receiver Timing Test Circuit

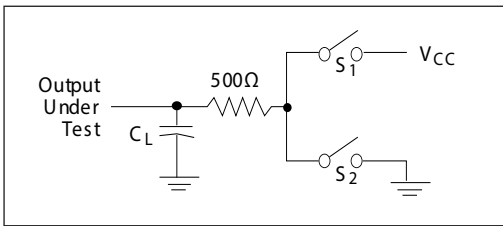

Figure 34. Driver Timing Test Load Circuit

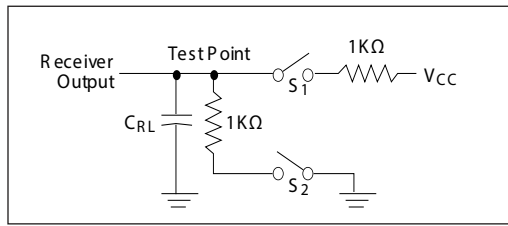

Figure 35. Receiver Timing Test Load Circuit

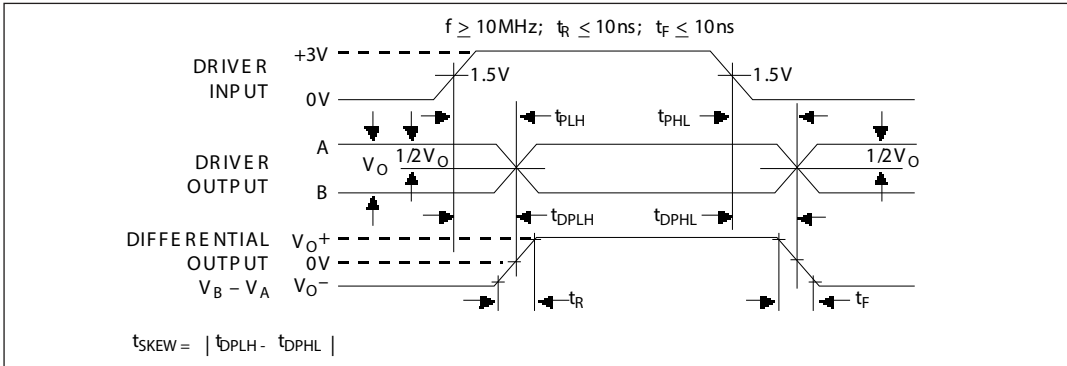

Figure 36. Driver Propagation Delays

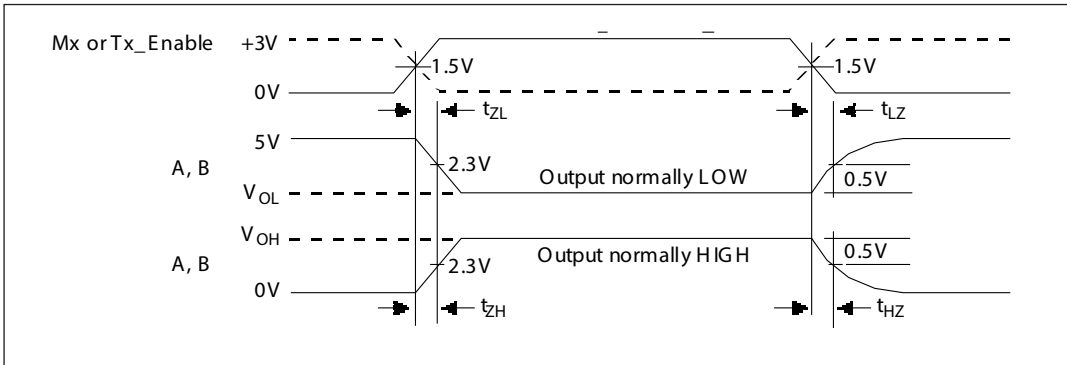

Figure 37. Driver Enable and Disable Times

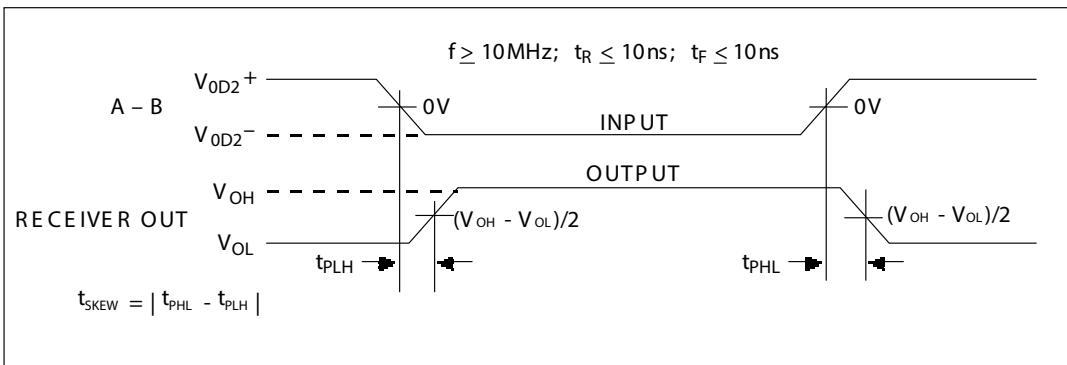

Figure 38. Receiver Propagation Delays

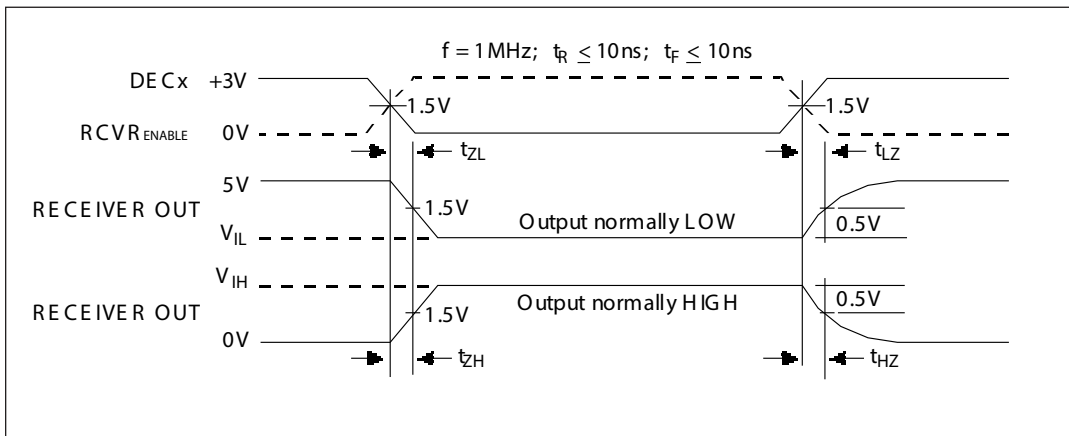

Figure 39. Receiver Enable and Disable Times

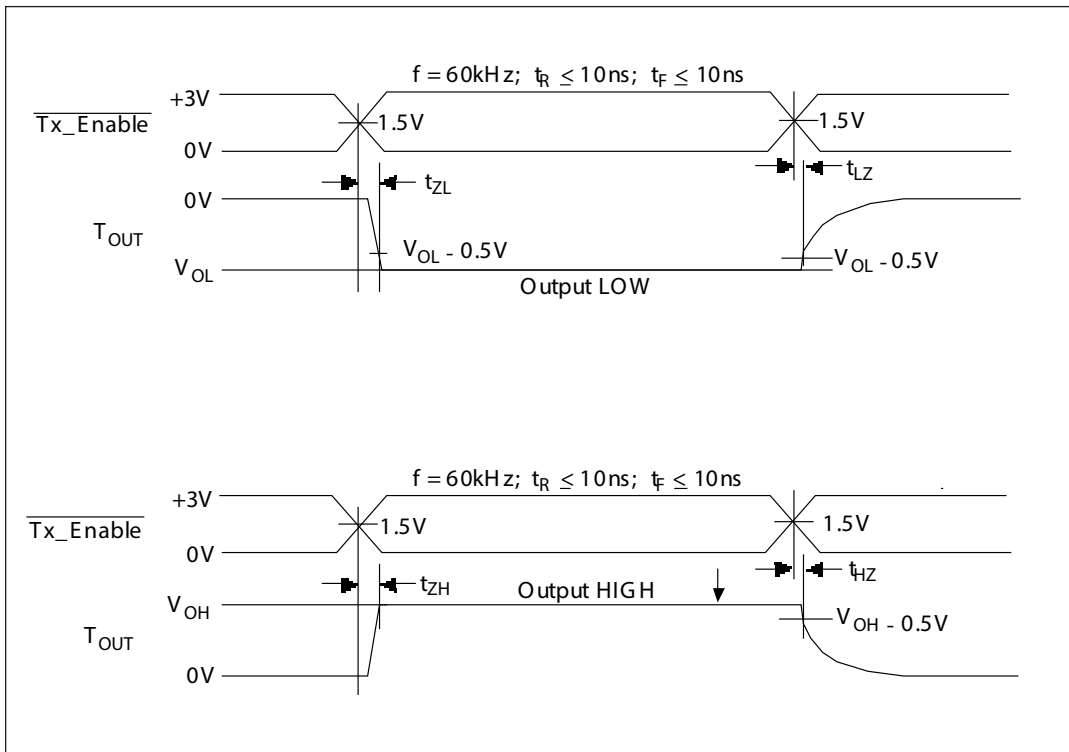

Figure 40. V.28 (RS-232) and V.10 (RS-423) Driver Enable and Disable Times

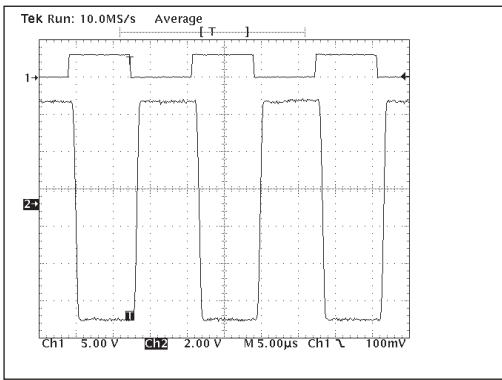

Figure 41. Typical V.28 Driver Output Waveform

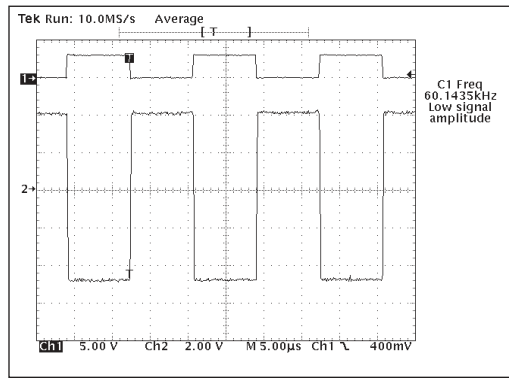

Figure 42. Typical V.10 Driver Output Waveform

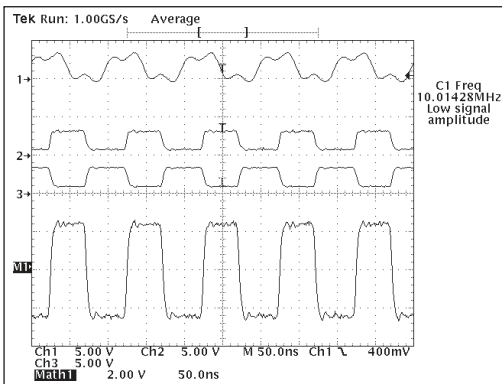

Figure 43. Typical V.11 Driver Output Waveform

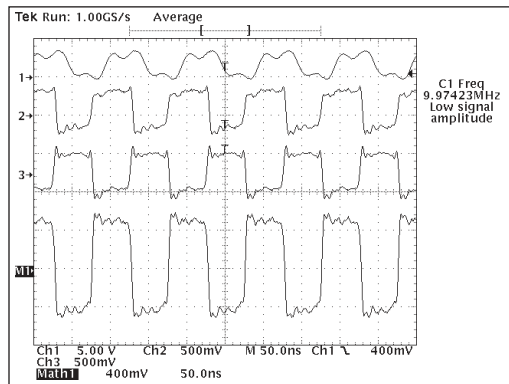

Figure 44. Typical V.35 Driver Output Waveform

VCC pins (1, 26, 45, 64, 71, 77, 80, 84, 88, 93, 98)
 GND pins (2, 25, 44, 52, 68, 74, 82, 86, 91, 96)
 N.C. pins (24 and 76)

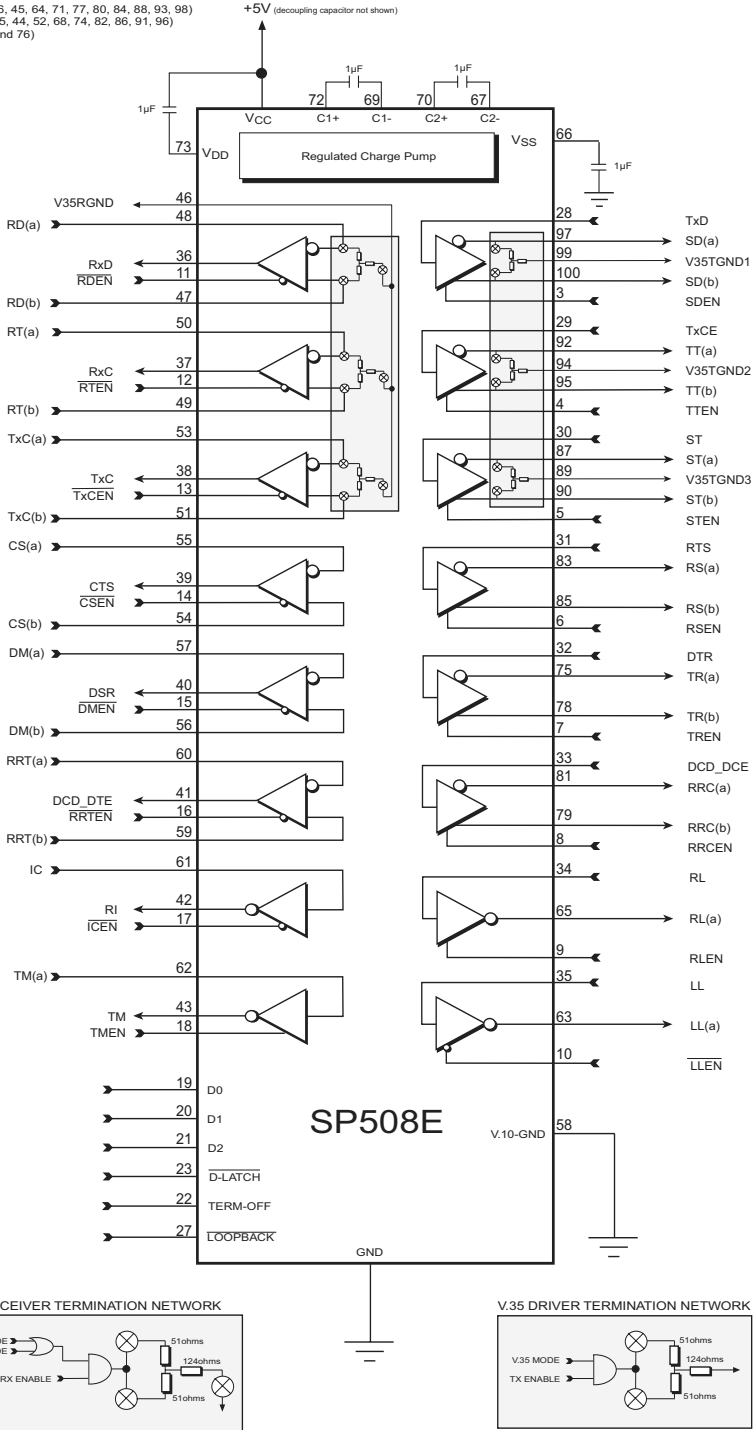

Figure 45. Functional Diagram

The SP508E contains highly integrated serial transceivers that offer programmability between interface modes through software control. The SP508E offers the hardware interface modes for RS-232 (V.28), RS-449/V.36 (V.11 and V.10), EIA-530 (V.11 and V.10), EIA-530A (V.11 and V.10), V.35 (V.35 and V.28) and X.21 (V.11). The interface mode selection is done via three control pins, which can be latched via microprocessor control.

The SP508E has eight drivers, eight receivers, and Exar's patented on-board charge pump (5,306,954) that is ideally suited for wide area network connectivity and other multi-protocol applications. Other features include digital and line loopback modes, individual enable/disable control lines for each driver and receiver, fail-safe when inputs are either open or shorted, individual termination resistor ground paths, separate driver and receiver ground outputs, enhanced ESD protection on driver outputs and receiver inputs.

THEORY OF OPERATION

The SP508E device is made up of 1) the drivers, 2) the receivers, 3) a charge pump, 4) DTE/DCE switching algorithm, and 5) control logic.

Drivers

The SP508E has eight enhanced independent drivers. Control for the mode selection is done via a three-bit control word into D0, D1, and D2. The drivers are prearranged such that for each mode of operation, the relative position and functionality of the drivers are set up to accommodate the selected interface mode. As the mode of the drivers is changed, the electrical characteristics will change to support the required signal levels. The mode of each driver in the different interface modes that can be selected is shown in Table 1.

There are four basic types of driver circuits – ITU-T-V.28 (RS-232), ITU-T-V.10 (RS-423), ITU-T-V.11 (RS-422), and CCITT-V.35.

The V.28 (RS-232) drivers output single-ended signals with a minimum of $\pm 5V$ (with $3k\Omega$ & $2500pF$ loading), and can operate over 120kbps. Since the SP508E uses a charge pump to generate the RS-232 output rails, the driver outputs will never exceed $\pm 10V$. The V.28 driver architecture is similar to Exar's standard line of RS-232 transceivers.

The RS-423 (V.10) drivers are also single-ended signals which produce open circuit V_{OL} and V_{OH} measurements of $\pm 4.0V$ to $\pm 6.0V$. When terminated with a 450Ω load to ground, the driver output will not deviate more than 10% of the open circuit value. This is in compliance of the ITU V.10 specification. The V.10 (RS-423) drivers are used in RS-449/V.36, EIA-530, and EIA-530A modes as Category II signals from each of their corresponding specifications. The V.10 drivers are guaranteed to transmit over 120kbps, but can operate at over 1Mbps if necessary.

The third type of drivers are V.11 (RS-422) differential drivers. Due to the nature of differential signaling, the drivers are more immune to noise as opposed to single-ended transmission methods. The advantage is evident over high speeds and long transmission lines. The strength of the driver outputs can produce differential signals that can maintain $\pm 2V$ differential output levels with a load of 100Ω . The signal levels and drive capability of these drivers allow the drivers to also support RS-485 requirements of $\pm 1.5V$ differential output levels with a 54Ω load. The strength allows the SP508E differential driver to drive over long cable lengths with minimal signal degradation. The V.11 drivers are used in RS-449, EIA-530, EIA-530A and V.36 modes as Category I signals which are used for clock and data. Exar's new driver design over its predecessors allow the SP508E to operate over 20Mbps for differential transmission.

The fourth type of drivers are V.35 differential drivers. There are only three available on the SP508E for data and clock (TxD, TxCE, and TxC in DCE mode). These drivers are current sources that drive loop current through a differential pair resulting in a 550mV differential voltage at the receiver. These drivers also incorporate fixed termination networks for each driver in order to set the V_{OH} and V_{OL} depending on load conditions. This termination network is basically a “Y” configuration consisting of two 51Ω resistors connected in series and a 124Ω resistor connected between the two 50Ω resistors and a V35TGND output. Each of the three drivers and its associated termination will have its own V35TGND output for grounding convenience. Filtering can be done on these pins to reduce common mode noise transmitted over the transmission line by connecting a capacitor to ground.

The drivers also have separate enable pins which simplifies half-duplex configurations for some applications, especially programmable DTE/DCE. The enable pins will either enable or disable the output of the drivers according to the appropriate active logic illustrated on Figure 45. The enable pins have internal pull-up and pull-down devices, depending on the active polarity of the receiver, that enable the driver upon power-on if the enable lines are left floating. During disabled conditions, the driver outputs will be at a high impedance 3-state.

The driver inputs are both TTL and CMOS compatible. All driver inputs have an internal pull-up resistor so that the output will be at a defined state at logic LOW (“0”). Unused driver inputs can be left floating. The internal pull-up resistor value is approximately 500kΩ.

Receivers

The SP508E has eight enhanced independent receivers. Control for the mode selection is done via a three-bit control word that is the same as the driver control word. Therefore, the modes for the drivers and receivers are identical in the application.

Like the drivers, the receivers are prear-

ranged for the specific requirements of the synchronous serial interface. As the operating mode of the receivers is changed, the electrical characteristics will change to support the required serial interface protocols of the receivers. Table 2 shows the mode of each receiver in the different interface modes that can be selected. There are two basic types of receiver circuits—ITU-T-V.28 (RS-232) and ITU-T-V.11, (RS-422).

The RS-232 (V.28) receiver is single-ended and accepts RS-232 signals from the RS-232 driver. The RS-232 receiver has an operating input voltage range of $\pm 15V$ and can receive signals down to $\pm 3V$. The input sensitivity complies with RS-232 and V.28 at $\pm 3V$. The input impedance is 3kΩ to 7kΩ in accordance to RS-232 and V.28. The receiver output produces a TTL/CMOS signal with a +2.4V minimum for a logic “1” and a +0.4V maximum for a logic “0”. The RS-232 (V.28) protocol uses these receivers for all data, clock and control signals. They are also used in V.35 mode for control line signals: CTS, DSR, LL, and RL. The RS-232 receivers can operate over 120kbps.

The second type of receiver is a differential type that can be configured internally to support ITU-T-V.10 and CCITT-V.35 depending on its input conditions. This receiver has a typical input impedance of 10kΩ and a differential threshold of less than $\pm 200mV$, which complies with the ITU-T-V.11 (RS-422) specifications. V.11 receivers are used in RS-449/V.36, EIA-530, EIA-530A and X.21 as Category I signals for receiving clock, data, and some control line signals not covered by Category II V.10 circuits. The differential V.11 transceiver has improved architecture that allows over 20Mbps transmission rates.

Receivers dedicated for data and clock (RxD, RxC, TxC) incorporate internal termination for V.11. The termination resistor is typically 120Ω connected between the A and B inputs. The termination is essential for minimizing crosstalk and signal reflection over the transmission line. The minimum value is guaranteed to exceed 100Ω, thus complying with the V.11 and RS-422 specifications.

This resistor is invoked when the receiver is operating as a V.11 receiver, in modes EIA-530, EIA-530A, RS-449/V.36, and X.21. The same receivers also incorporate a termination network internally for V.35 applications. For V.35, the receiver input termination is a “Y” termination consisting of two 51Ω resistors connected in series and a 124Ω resistor connected between the two 50Ω resistors and V35RGND output. The V35RGND is usually grounded. The receiver itself is identical to the V.11 receiver.

The differential receivers can be configured to be ITU-T-V.10 single-ended receivers by internally connecting the non-inverting input to ground. This is internally done by default from the decoder. The non-inverting input is rerouted to V10GND and can be grounded separately. The ITU-T-V.10 receivers can operate over 1Mbps and are used in RS-449/V.36, E1A-530, E1A-530A and X.21 modes as Category II signals as indicated by their corresponding specifications. All receivers include an enable/disable line for disabling the receiver output allowing convenient half-duplex configurations. The enable pins will either enable or disable the output of the receivers according to the appropriate active logic illustrated on Figure 45. The receiver’s enable lines include an internal pull-up or pull-down device, depending on the active polarity of the receiver, that enables the receiver upon power up if the enable lines are left floating. During disabled conditions, the receiver outputs will be at a high impedance state. If the receiver is disabled any associated termination is also disconnected from the inputs.

All receivers include a fail-safe feature that outputs a logic high when the receiver inputs are open, terminated but open, or shorted together. For single-ended V.28 and V.10 receivers, there are internal 5kΩ pull-down resistors on the inputs which produces a logic high (“1”) at the receiver outputs. The differential receivers have a proprietary circuit that detect open or shorted inputs and if so, will produce a logic HIGH (“1”) at the receiver output.

CHARGE PUMP

The charge pump is a Exar-patented design (5,306,954) and uses a unique approach compared to older less-efficient designs. The charge pump still requires four external capacitors, but uses four-phase voltage shifting technique to attain symmetrical power supplies. The charge pump V_{DD} and V_{SS} outputs are regulated to +5.8V and -5.8V, respectively. There is a free-running oscillator that controls the four phases of the voltage shifting. A description of each phase follows.

Phase 1

— V_{SS} charge storage —During this phase of the clock cycle, the positive side of capacitors C_1 and C_2 are initially charged to V_{CC} . C_1+ is then switched to ground and the charge in C_1- is transferred to C_2- . Since C_2+ is connected to V_{CC} , the voltage potential across capacitor C_2 is now $2 \times V_{CC}$.

Phase 2

— V_{SS} transfer —Phase two of the clock connects the negative terminal of C_2 to the V_{SS} storage capacitor and the positive terminal of C_2 to ground, and transfers the negative generated voltage to C_3 . This generated voltage is regulated to -5.8V. Simultaneously, the positive side of the capacitor C_1 is switched to V_{CC} and the negative side is connected to ground.

Phase 3

— V_{DD} charge storage —The third phase of the clock is identical to the first phase—the charge transferred in C_1 produces $-V_{CC}$ in the negative terminal of C_1 which is applied to the negative side of the capacitor C_2 . Since C_2+ is at V_{CC} , the voltage potential across C_2 is $2 \times V_{CC}$.

Phase 4

— V_{DD} transfer —The fourth phase of the clock connects the negative terminal of C_2 to ground, and transfers the generated 5.8V across C_2 to C_4 , the V_{DD} storage capacitor. This voltage is regulated to +5.8V. At the regulated voltage, the internal oscillator is disabled and simultaneously with this, the positive side of capacitor C_1 is switched to V_{CC} and the negative side is connected to ground, and the cycle begins again.

The charge pump cycle will continue as long as the operational conditions for the internal oscillator are present.

Since both V^+ and V^- are separately generated from V_{CC} ; in a no-load condition V^+ and V^- will be symmetrical. Older charge pump approaches that generate V^- from V^+ will show a decrease in the magnitude of V^- compared to V^+ due to the inherent inefficiencies in the design.

The clock rate for the charge pump typically operates at 250kHz. The external capacitors can be as low as 1 μ F with a 16V breakdown voltage rating.

TERM_OFF FUNCTION

The SP508E contains a TERM_OFF pin that disables all three receiver input termination networks regardless of mode. This allows the device to be used in monitor mode applications that are typically found in networking test equipment. The TERM_OFF pin internally contains a pull-down device with an impedance of over 500k Ω , which will default in a "ON" condition during power-up if V.35 receivers are used. The individual receiver enable line and the SHUTDOWN mode from the decoder will disable the termination regardless of TERM_OFF.

LOOPBACK FUNCTION

The SP508E contains a LOOPBACK pin that invokes a loopback path. This loopback path is illustrated in Figure 46. LOOPBACK has an internal pull-up resistor that defaults to normal mode during power up or if the pin is left floating. During loopback, the driver output and receiver input characteristics will still adhere to its appropriate specifications.

DECODER AND D_LATCH FUNCTION

The SP508E contains a D_LATCH pin that latches the data into the D0, D1, and D2 decoder inputs. If tied to a logic LOW ("0"), the latch is transparent, allowing the data at the decoder inputs to propagate through and program the SP508E accordingly. If tied to a logic HIGH("1"), the latch locks out the data and prevents the mode from changing until this pin is brought to a logic LOW.

There are internal pull-up devices on D0, D1, and D2, which allow the device to be in SHUTDOWN mode ("111") upon power up. However, if the device is powered -up with the D_LATCH at a logic HIGH, the decoder state of the SP508E will be undefined.

ESD TOLERANCE

The SP508E device incorporates ruggedized ESD cells on all driver output and receiver input pins. The ESD structure is improved over our previous family for more rugged applications and environments sensitive to electrostatic discharges and associated transients.

CTR1/CTR2 EUROPEAN COMPLIANCY

As with all of Exar's previous multi-protocol serial transceiver IC's, the drivers and receivers have been designed to meet all the requirements to NET1/NET2 and TBR2 in order to meet CTR1/CTR2 compliancy. The SP508E is also tested in-house at Exar and adheres to all the NET1/2 physical layer testing and the ITU Series V specifications before shipment. Please note that although the SP508E, as with its predecessors, adhere to CTR1/CTR2 compliancy testing, any complex or unusual configuration should be double-checked to ensure CTR1/CTR2 compliance. Consult the factory for details.

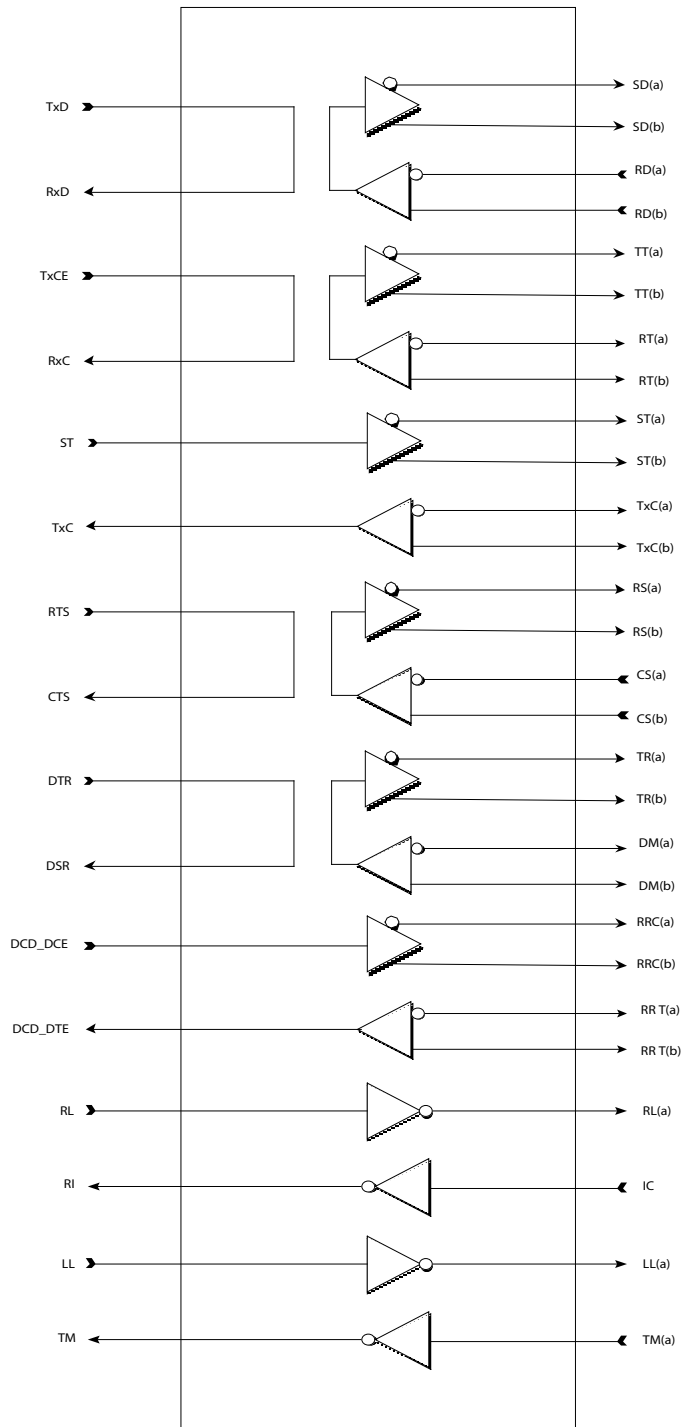

Figure 46. SP508E Loopback Path

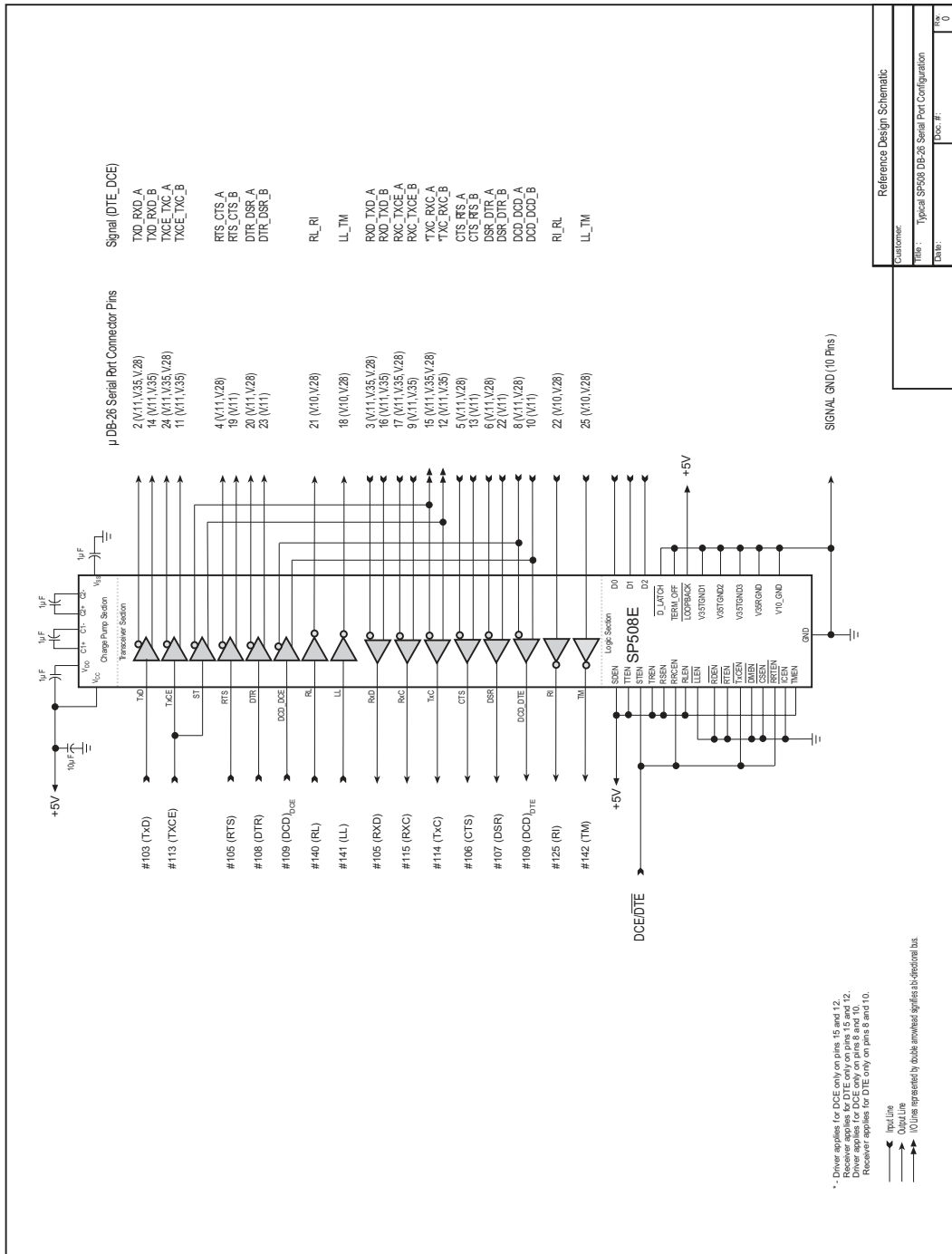
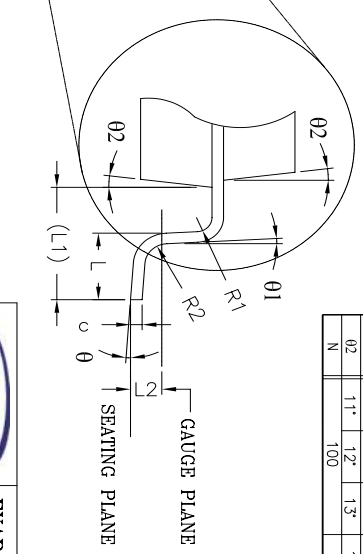
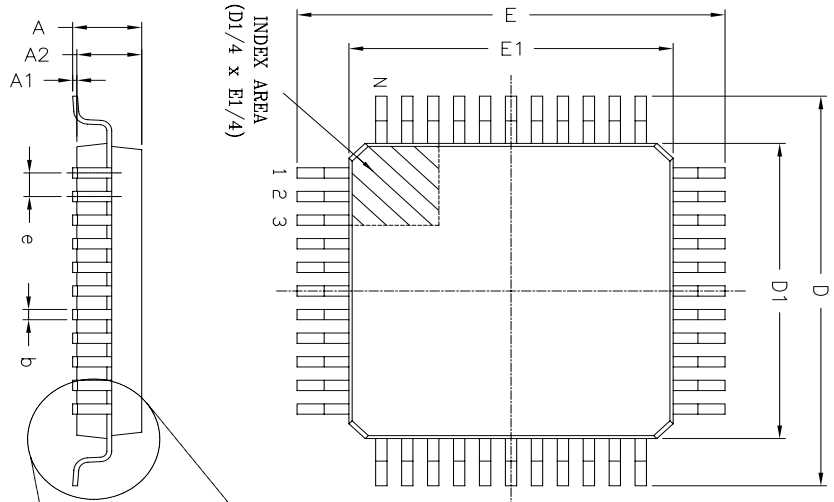

Figure 47. SP508E Typical Operating Configuration to Serial Port Connector with DCE/DTE programmability

REVISION HISTORY			
REV.	DESCRIPTION	DATE	APP'D.
A	DRAWING ORGANIZATION	05/03/06	JL
B	CHANGE DRAWING LOGO AND COMPANY NAME	11/21/07	JL

100 Pin LQFP JEDEC MS-026 Variation BFD					
SYMBOLS	DIMENSIONS IN MM (Control Unit)		DIMENSIONS IN INCH (Reference Unit)		
	MIN	MAX	MIN	NOM	MAX
A	—	1.60	—	—	0.063
A1	0.05	—	0.15	0.002	—
A2	1.35	1.40	0.053	0.055	0.057
b	0.17	0.22	0.027	0.009	0.011
c	0.09	—	0.20	0.004	—
D	16.00 BSC				
D1	14.00 BSC				
E	16.00 BSC				
E1	14.00 BSC				
e	0.50 BSC				
L	0.45	0.60	0.75	0.018	0.024
L1	1.00 REF				
L2	0.25 BSC				
R1	0.08	—	—	0.003	—
R2	0.08	—	0.20	0.003	—
θ	0°	3.5°	7°	0°	3.5°
θ1	0°	—	—	0°	—
θ2	11°	12°	13°	11°	12°
N	100		100		



		EXAR CORPORATION	
Packaging Approval:		100 PIN LQFP PACKAGE OUTLINE	
By: JL		Drawing No: 100-PIN LQFP	
Date: 11/21/07		Revision: B	
		Sheet: 1 OF 1	

SP508 Multiprotocol Configured as DCE

Interface to System Logic			Interface to Port Connector		
Pin Number	Pin Mnemonic	Circuit	Pin Mnemonic	Pin Number	Pin Number
28	TXD	Driver_1	SD(A)	97	
3	SDEN		SD(B)	100	
29	TXCE	Driver_2	TT(A)	92	
4	TTEH		TT(B)	95	
30	STEN	Driver_3	ST(A)	87	
5	STEN		ST(B)	90	
31	RYS	Driver_4	RS(A)	85	
6	RSEN		RS(B)	88	
32	DTREH	Driver_5	DT(A)	75	
7	DTREH		DT(B)	78	
33	D.C.D.DTCE	Driver_6	TR(A)	81	
8	RRCEN		RRC(B)	79	
34	RL	Driver_7	RL(A)	65	
9	RLEN				
35	LL	Driver_8	LL(A)	63	
10	LLEN#				
36	RxD	Receiver_1	RD(A)	48	
11	RDEN#		RD(B)	47	
37	RxC	Receiver_2	RT(A)	50	
12	RTEN#		RT(B)	49	
38	TxC	Receiver_3	TX(A)	53	
13	TXEN#		TX(B)	51	
39	CTS	Receiver_4	CS(A)	55	
14	CSEN#		CS(B)	54	
40	DSR	Receiver_5	DM(A)	57	
15	DMEN#		DM(B)	56	
41	D.C.D.DTCE	Receiver_6	RR(A)	60	
16	RRTEN#		RR(B)	59	
42	RI	Receiver_7	K	61	
17	KEN#				
43	TM	Receiver_8	TM(A)	62	
18	TMEN				

Spine drivers and receivers may be used for optional signals (Signal Quality, Rate Detect, Standby) or may be disabled using individual enable pins for each driver and receiver

Recommended Signals and Port Pin Assignments

RS-232 or V24			EIA-520			RS-449			V35			X.21		
Signal Type	Mnemonic	DB-25 Pin(F)	Signal Type	Mnemonic	DB-25 Pin(F)	Signal Type	Mnemonic	DB-37 Pin(F)	Signal Type	Mnemonic	M34 Pin(F)	Signal Type	Mnemonic	DB-15 Pin(F)
V28	8B	3	V11	8B(A)	3	V11	RD(A)	6	V35	104	R	V11	RD(A)	4
V28	DD	17	V11	DD(B)	16	V11	RD(B)	24	V35	104	T	V11	RD(B)	11
V28	DB	15	V11	DD(B)	17	V11	RT(A)	8	V35	115	V	V11	RD(A)	7**
V28	DB	15	V11	DB(A)	15	V11	RT(B)	26	V35	115	X	V11	RD(B)	14**
V28	CB	5	V11	DB(B)	12	V11	ST(A)	5	V35	114	Y	V11	SD(A)	6
V28	CC	6	V11	CB(A)	5	V11	ST(B)	23	V35	114	AA	V11	SD(B)	13
V28	CF	8	V11	CB(B)	5	V11	CS(A)	9	V28	106	D	V11	RA)	5
V28	CE	22	V11	CF(B)	10	V11	CS(B)	27				V11	RB)	12
V28	TM	25	V10	TM	25	V10	DM(A)	11	V28	107	E			
V28	BA	2	V11	CC(B)	22	V11	DM(B)	29	V28	109	F			
V28	DA	24	V11	CF(A)	8	V11	RM(A)	13	V28	125	J			
V28	DA	24	V11	CF(B)	10	V11	RM(B)	31						
V28	BA	2	V11	TM	25	V10			V28	142	NN			
V28	DA	24	V11	BA(A)	2	V11	SD(A)	4	V35	103	P	V11	TR(A)	2
V28	DA	24	V11	BA(B)	12	V11	SD(B)	22	V35	103	S	V11	TR(B)	9
V28	DA	24	V11	DA(A)	24	V11	TT(A)	17	V35	113	U	V11	X(A)	7**
V28	CA	4	V11	DA(B)	11	V11	TT(B)	35	V35	113	W	V11	X(B)	14**
V28	CA	4	V11	CA(A)	4	V11	RS(A)	7	V28	105	C	V11	CA)	3
V28	CD	20	V11	CA(B)	19	V11	RS(B)	25				V11	CB)	10
V28	CD	20	V11	CD(A)	20	V11	TR(A)	12	V28	108	H			
V28	RL	21	V11	CD(B)	23	V11	TR(B)	30						
V28	LL	18	V10	RL	21	V10			V28	140	N			
V28	LL	18	V10	LL	18	V10			V28	141	L			

Pin assignments and signal functions are subject to national or regional variation and proprietary / non-standard implementations

**X.21 use either 80 or X0, not both

DTE CONFIGURATION

SP508 Multiprotocol Configured as DTE

Interface to System Logic			Interface to Port Connector		
Pin Number	Pin Mnemonic	Circuit	Pin Mnemonic	Pin Number	
28	TxD	Driver_1	SD(A)	97	
3	SDEN		SD(B)	100	
29	TxC/E	Driver_2	TT(A)	92	
4	TTEH		TT(B)	95	
30	ST	Driver_3	ST(B)	87	
5	STEN		ST(B)	90	
31	RTS	Driver_4	RS(B)	89	
6	RTEN		RS(B)	89	
32	DTX	Driver_5	TR(B)	75	
7	TREN		TR(B)	78	
33	DCCD_DCE	Driver_6	RR(C)	81	
8	RR(CEN)		RR(C)	79	
34	RL	Driver_7	RL(A)	65	
9	RLEN				
35	LL	Driver_8	LL(A)	63	
10	LLEN#				
36	RxD	Receiver_1	RO(A)	48	
11	RO(B#)		RO(B)	47	
37	RxC	Receiver_2	RT(A)	50	
12	RTEN#		RT(B)	49	
38	TxC	Receiver_3	TX(C)	53	
13	TxC/EN#		TX(C)	51	
39	CTS	Receiver_4	CS(A)	55	
14	CSEN#		CS(B)	54	
40	DSR	Receiver_5	DM(A)	57	
15	DMEN#		DM(B)	56	
41	DCCD_DTE	Receiver_6	RR7(B)	60	
16	RR7EN#		RR7(B)	59	
42	RI	Receiver_7	IC	61	
17	RIEN#				
43	TM(A)	Receiver_8	TM(A)	62	
18	TM(B)				

Spine drivers and receivers may be used for optional signals (Signal Quality, Rate Detect, Standby) or may be disabled using individual enable pins for each driver and receiver

Recommended Signals and Port Pin Assignments

RS-232 or V24			EIA-530			RS-449			V3.5			X.21			AppleLink™		
Signal Type	Mnemonic	D8-25 Pin/ID	Signal Type	Mnemonic	D8-25 Pin/ID	Signal Type	Mnemonic	D8-37 Pin/ID	Signal Type	Mnemonic	MS4 Pin/ID	Signal Type	Mnemonic	D8-15 Pin/ID	Signal Type	Mnemonic	DM48 Pin/ID
V28	BA	2	BA(A)	2	W1	SD(A)	4	V35 103	P	V11 TR	2	V11	TXD+	3			
V28	DA	24	DA(A)	24	V11 TT(A)	17	V35 113	U	V11 TX	9	V11	TXD+	6				
			DA(B)	11			35	V35 113	W	V11 X(B)	14**						
V28	CA	4	CA(A)	4	V11 RS(A)	7	V28 105	C	V11 C(A)	3							
			CA(B)	19	V11 RS(B)	25	V28 108	H	V11 C(B)	10							
V28	CD	20	CD(A)	20	V11 TR(A)	12											
			CD(B)	23	V11 TR(B)	30											
V28	RL	21	RL	21	V10	RL	14	V28 140	N								
V28	LL	18	LL	18	V10	LL	10	V28 141	L								
V28	BB	3	BB(A)	3	V11 RO(A)	6	V35 104	R	V11 RB	4	V11 RD-	5					
			BB(B)	16	V11 RO(B)	24	V35 104	T	V11 RB	11	V11 RD+	8					
V28	DD	17	DD(A)	17	V11 RT(A)	8	V35 115	V									
			DD(B)	9	V11 RT(B)	5	V35 115	X									
V28	D8	15	D8(A)	15	V11 ST(A)	26	V35 114	Y	V11 SA	6							
			D8(B)	12	V11 ST(B)	23	V35 114	AA	V11 SB	13							
V28	CB	5	CB(A)	5	V11 CS(A)	9	V28 106	D	V11 CA	5							
			CB(B)	13	V11 CS(B)	27											
V28	CC	6	CC(A)	6	V11 DM(A)	11	V28 107	E	V11 CB	12	V10* HSB	7					
			CC(B)	22*	V11 DM(B)	29											
V28	CF	8	CF(A)	8	V11 RR(A)	13	V28 109	F	V11 CB	7**	V10 GPI	2					
			CF(B)	10	V11 RR(B)	31											
V28	CE	22	CE	22*	V10	RI	V28 125	J									
V28	TM	25	TM	25	V10	TM	V28 142	NN									

Pin assignments and signal functions are subject to national or regional variation and proprietary / non-standard implementations
 * EIA-530 uses V11 differential implementations
 † EIA-530 uses V11 differential for DSR, CCA and DTR, C(D) signals; EIA-530-A uses single-ended V10 for DSR and DTR and adds RI signal on pin 22

** X.21 uses either B0 or X0, not both

ORDERING INFORMATION⁽¹⁾

PART NUMBER	TEMPERATURE RANGE	PACKAGE	PACKAGING METHOD	LEAD-FREE ⁽²⁾
SP508ECF-L	0°C to 70°C	100 Lead LQFP	Tray	Yes
SP508EEF-L	-40°C to 85°C	100 Lead LQFP	Tray	Yes

NOTES:

1. Refer to <http://www.maxlinear.com/SP508E> for most up-to-date Ordering Information.
2. Visit www.maxlinear.com for additional information on Environmental Rating.

REVISION HISTORY

DATE	REVISION	DESCRIPTION
07/24/12	1.0.0	Production Release
01/30/20	1.0.1	Update to MaxLinear logo. Update ordering information.



MaxLinear, Inc.
5966 La Place Court, Suite 100
Carlsbad, CA 92008
760.692.0711 p.
760.444.8598 f.
www.maxlinear.com

The content of this document is furnished for informational use only, is subject to change without notice, and should not be construed as a commitment by MaxLinear, Inc. MaxLinear, Inc. assumes no responsibility or liability for any errors or inaccuracies that may appear in the informational content contained in this guide. Complying with all applicable copyright laws is the responsibility of the user. Without limiting the rights under copyright, no part of this document may be reproduced into, stored in, or introduced into a retrieval system, or transmitted in any form or by any means (electronic, mechanical, photocopying, recording, or otherwise), or for any purpose, without the express written permission of MaxLinear, Inc.

Maxlinear, Inc. does not recommend the use of any of its products in life support applications where the failure or malfunction of the product can reasonably be expected to cause failure of the life support system or to significantly affect its safety or effectiveness. Products are not authorized for use in such applications unless MaxLinear, Inc. receives, in writing, assurances to its satisfaction that: (a) the risk of injury or damage has been minimized; (b) the user assumes all such risks; (c) potential liability of MaxLinear, Inc. is adequately protected under the circumstances.

MaxLinear, Inc. may have patents, patent applications, trademarks, copyrights, or other intellectual property rights covering subject matter in this document. Except as expressly provided in any written license agreement from MaxLinear, Inc., the furnishing of this document does not give you any license to these patents, trademarks, copyrights, or other intellectual property.

MaxLinear, the MaxLinear logo, and any MaxLinear trademarks, MxL, Full-Spectrum Capture, FSC, G.now, AirPHY and the MaxLinear logo are all on the products sold, are all trademarks of MaxLinear, Inc. or one of MaxLinear's subsidiaries in the U.S.A. and other countries. All rights reserved. Other company trademarks and product names appearing herein are the property of their respective owners.