

DESCRIPTION

The LX8941 is an adjustable, low dropout regulator rated for more than 1A of output current. It can regulate with as low as 0.8V headroom between the input and output voltages, at 1A output current, thus minimizing power dissipation. In addition, it can be used in applications where worst case supplies require a low input output differential to maintain regulation.

This feature makes it ideal for some processor applications that require 4V operation from a 5V supply. In addition, the LX8941 provides an on/off switch that reduces the IC quiescent current when activated, making it ideal for battery operated applications.

KEY FEATURES

- 2% Internally Trimmed Output
- Output Current In Excess of 1A
- Input-Output Differential Less Than 0.8V @ 1A
- Reverse Battery Protection
- Short Circuit Protection
- Internal Thermal Overload Protection
- Available in 5-Lead Plastic TO-220 & Surface-Mount TO-263

IMPORTANT: For the most current data, consult MICROSEMI's website: <http://www.microsemi.com>

PRODUCT HIGHLIGHT

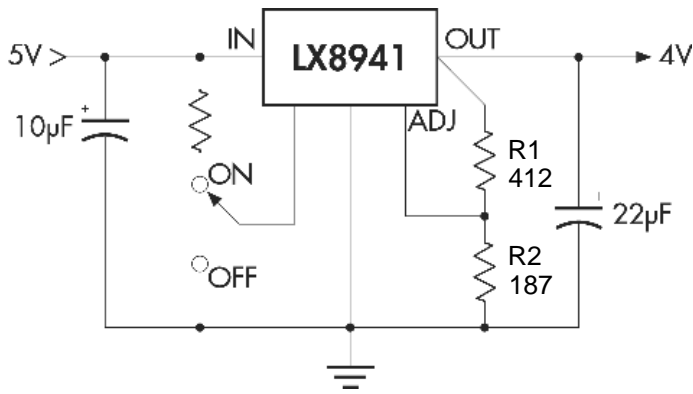

$$V_O = V_{ADJ} \times \left(1 + \frac{R1}{R2} \right) + I_{ADJ} \times R1$$

DROPOUT VOLTAGE VS. OUTPUT CURRENT VS. TEMPERATURE

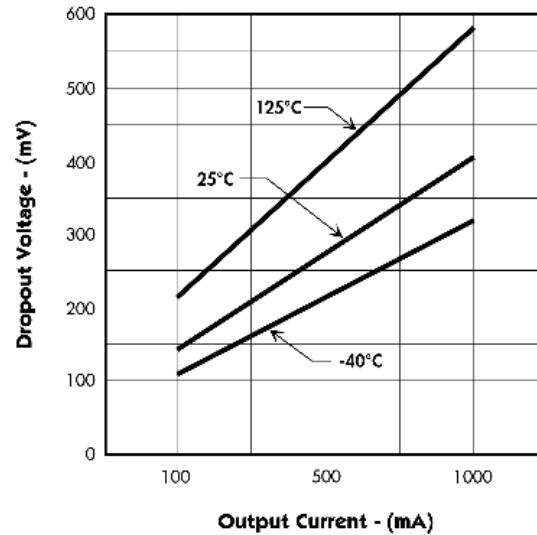

PACKAGE ORDER INFO

T _A (°C)	P	Plastic TO-220 5-Pin	DD	Plastic TO-263 5-Pin
0 to 70		LX8941CP		LX8941CDD

Note: Available in Tape & Reel.
Append the letter "T" to the part number. (i.e. LX8941CDDT)

LX8941

ADJUSTABLE LOW DROPOUT REGULATOR

PRELIMINARY DATA SHEET

ABSOLUTE MAXIMUM RATINGS (Note 1)

Input Voltage (V_{IN})	26V
Operating Junction Temperature	
Plastic (P, DD Package)	150°C
Storage Temperature Range	-65°C to 150°C
Lead Temperature (Soldering, 10 seconds)	300°C

Note 1. Exceeding these ratings could cause damage to the device. All voltages are with respect to Ground. Currents are positive into, negative out of the specified terminal.

THERMAL DATA

P PACKAGE:

THERMAL RESISTANCE-JUNCTION TO TAB, θ_{JT}	4.5°C/W
THERMAL RESISTANCE-JUNCTION TO AMBIENT, θ_{JA}	60°C/W

DD PACKAGE:

THERMAL RESISTANCE-JUNCTION TO TAB, θ_{JT}	4.5°C/W
THERMAL RESISTANCE-JUNCTION TO AMBIENT, θ_{JA}	60°C/W

Junction Temperature Calculation: $T_j = T_A + (P_D \times \theta_{JA})$.

The θ_{JA} numbers are guidelines for the thermal performance of the device/pc-board system. All of the above assume no ambient airflow.

PACKAGE PIN OUTS

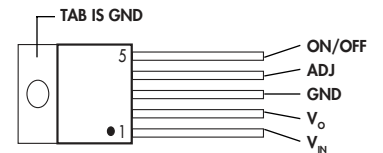

P PACKAGE
(Top View)

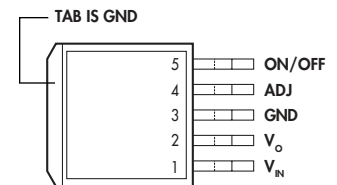

DD PACKAGE
(Top View)

BLOCK DIAGRAM

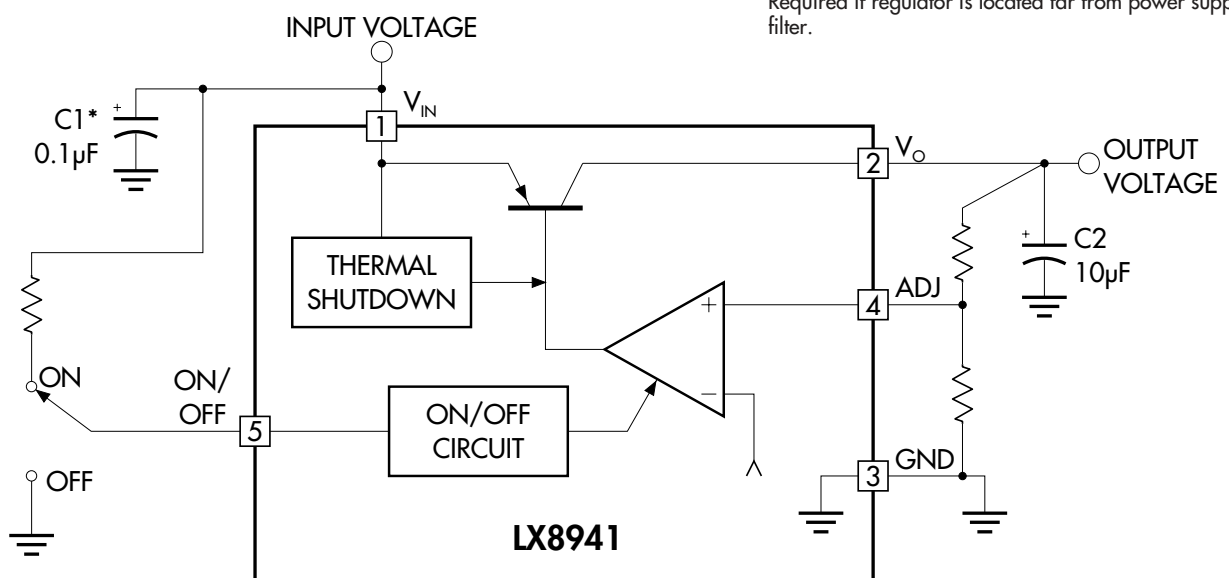

* Required if regulator is located far from power supply filter.

ADJUSTABLE LOW DROPOUT REGULATOR

PRELIMINARY DATA SHEET

RECOMMENDED OPERATING CONDITIONS

Parameter	Symbol	Recommended Operating Conditions			Units
		Min.	Typ.	Max.	
Input Voltage (Note 2)	V_{IN}	3.8		26	V
Load Current (with adequate heatsinking)		5		1000	mA
Input Capacitor (V_{IN} to GND)		0.1			μ F
Output Capacitor with ESR of 10Ω max., (V_{OUT} to GND)		10			μ F

Note 2. $V_{IN(MIN)} = V_{OUT} + 1.2\Delta V_{(MAX)}$. See Dropout Voltage maximum limit.

ELECTRICAL CHARACTERISTICS

Unless otherwise specified, these specifications apply over the operating ambient temperature of 0°C to $+125^{\circ}\text{C}$ for LX8941CP; $V_{IN} = 10\text{V}$, $I_O = 1\text{A}$, $C_{OUT} = 22\mu\text{F}$, and are for DC characteristics only. (Low duty cycle pulse testing techniques are used which maintains junction and case temperatures equal to the ambient temperature.) Note 3: The output voltage range is 4 to 25V and is determined by the two external resistors, R1 and R2. See Product Highlight.

Parameter	Symbol	Test Conditions	LX8941			Units
			Min.	Typ.	Max.	
ADJ Pin Voltage (Note 3)	V_{ADJ}	$I_O = 0\text{A}$, $T_A = 25^{\circ}\text{C}$	1.225	1.25	1.275	V
Line Regulation	ΔV_{OL}	$V_O + 2\text{V} \leq V_{IN} \leq 26\text{V}$, $I_O = 5\text{mA}$		1	50	mV
Load Regulation	ΔV_{OL}	$50\text{mA} \leq I_O \leq 1\text{A}$, $V_O = V_{ADJ}$		10	50	mV
Dropout Voltage	ΔV	$I_O = 100\text{mA}$		150	300	mV
		$I_O = 500\text{mA}$		275	500	mV
		$I_O = 1\text{A}$		400	800	mV
Quiescent Current	I_Q	$I_O \leq 5\text{mA}$, $7 \leq V_{IN} \leq 26\text{V}$		3	15	mA
		$I_O = 500\text{mA}$		30	50	mA
		$I_O = 1000\text{mA}$		115	180	mA
Adjust Pin Current	I_{ADJ}	$V_{IN} = 10\text{V}$, $I_O = 1\text{A}$		2	20	μ A
Current Limit	I_{CL}	$V_{IN} = 26\text{V}$	1	1.2		A
Output Noise Voltage (Note 4)	$V_{O(RMS)}$	10Hz - 100kHz, $I_O = 5\text{mA}$		150		μ V _{RMS}
Long Term Stability (Note 4)				20		mV/1000hr
Ripple Rejection (Note 4)	R_R	$f_O = 120\text{Hz}$, $1V_{RMS}$, $I_O = 100\text{mA}$		66		dB
Enable Logic Section						
On Threshold Voltage			2			V
On Threshold Current				0.1	50	μ A
Off Threshold Voltage					0.8	V
Off Threshold Current			-10	-0.3		μ A

Note 4: These parameters although guaranteed, are not tested in production.

PRELIMINARY DATA - Information contained in this document is pre-production data, and is proprietary to Linfinity. It may not be modified in any way without the express written consent of Linfinity. Product referred to herein is offered in sample form only, and Linfinity reserves the right to change or discontinue this proposed product at any time.