

## Two Pair, N- and P-Channel Enhancement-Mode MOSFET with Drain-Diodes

### Features

- ▶ High voltage Vertical DMOS technology
- ▶ Integrated drain output high voltage diodes
- ▶ Integrated gate-to-source resistor
- ▶ Integrated gate-to-source Zener diode
- ▶ Low threshold, Low on-resistance
- ▶ Low input & output capacitance
- ▶ Fast switching speeds
- ▶ Electrically isolated N- and P-MOSFET pairs

### Applications

- ▶ High voltage pulsers
- ▶ Amplifiers
- ▶ Buffers
- ▶ Piezoelectric transducer drivers
- ▶ General purpose line drivers
- ▶ Logic level interfaces

### General Description

The Supertex TC7920 consists of two pairs of high voltage, low threshold N-channel and P-channel MOSFETs in a 12-Lead DFN package. All MOSFETs have integrated the output drain high voltage diodes, gate-to-source resistors and gate-to-source Zener diode clamps which are desired for high voltage pulser applications. The complimentary, high-speed, high voltage, gate-clamped N and P-channel MOSFET pairs utilize an advanced vertical DMOS structure and Supertex's well-proven silicon-gate manufacturing process. This combination produces a device with the power handling capabilities of bipolar transistors and with the high input impedance and positive temperature coefficient inherent in MOS devices.

Characteristic of all MOS structures, these devices are free from thermal runaway and thermally induced secondary breakdown. Supertex's vertical DMOS FETs are ideally suited to a wide range of switching and amplifying applications where very low threshold voltage, high breakdown voltage, high input impedance, low input and output capacitance, and fast switching speeds are desired.

### Typical Application Circuit

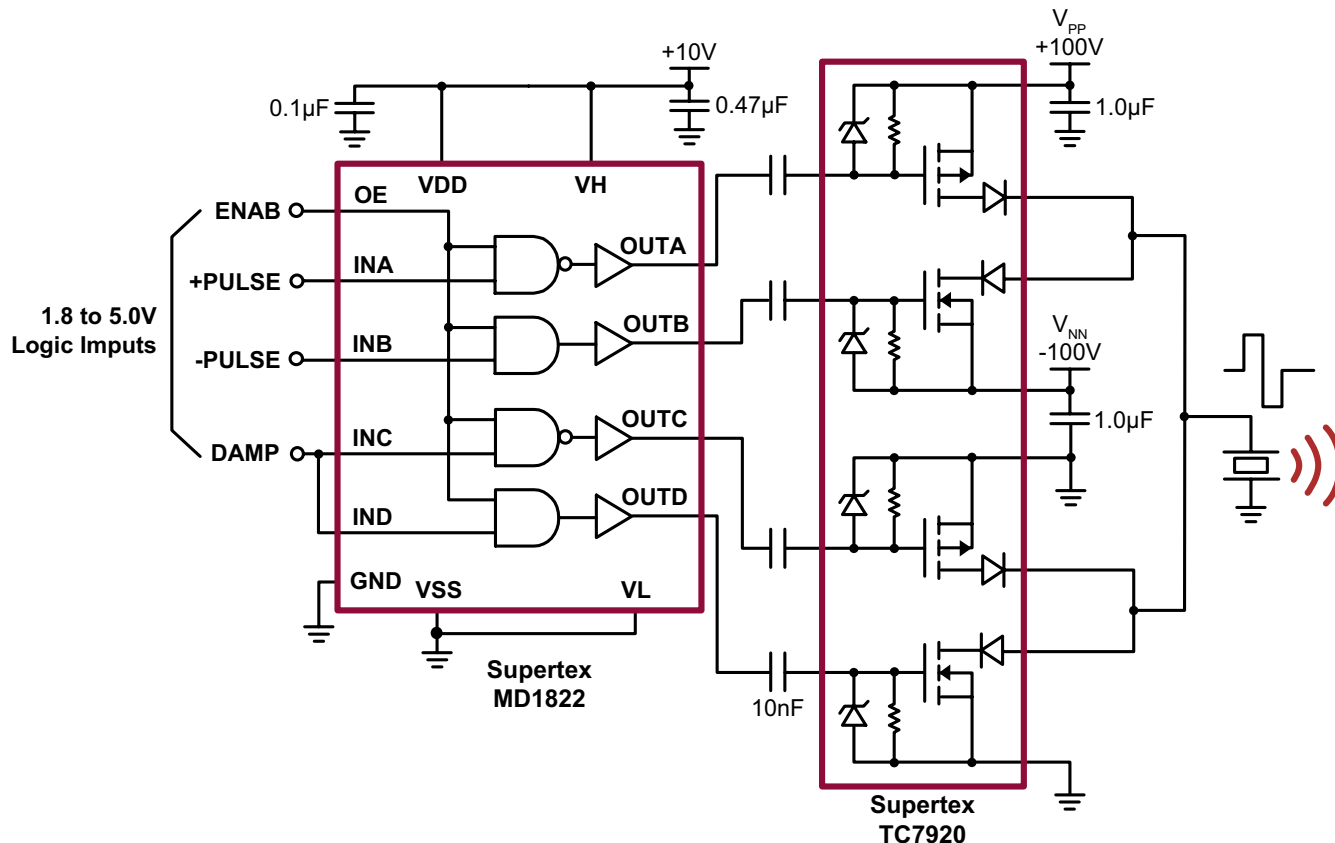

## Ordering Information

Part Number	Package Option	Packing
TC7920K6-G	12-Lead DFN	3000/Reel

## Absolute Maximum Ratings

Parameter	Value
Drain-to-source voltage	$BV_{DSS}$
Drain-to-gate voltage	$BV_{DGS}$
Operating and storage temperature	-55°C to +150°C

Absolute Maximum Ratings are those values beyond which damage to the device may occur. Functional operation under these conditions is not implied. Continuous operation of the device at the absolute rating level may affect device reliability. All voltages are referenced to device ground.

## Typical Thermal Resistance

Package	$\theta_{ja}$
12-Lead DFN	42°C/W

Note:  
1.0oz, 4-layer, 3"x4" PCB.

## Product Summary

$BV_{DSS}/BV_{DGS}$		$R_{DS(ON)}$ (max)	
N-Channel	P-Channel	N-Channel	P-Channel
200V	-200V	7.0Ω	8.0Ω

## Pin Configuration

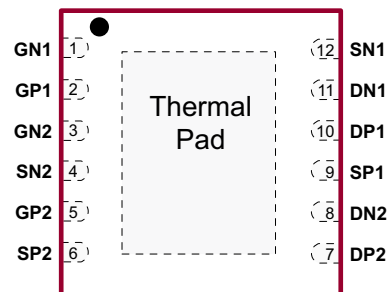

12-Lead DFN  
(top view)

## Package Marking



Y = Last Digit of Year Sealed  
W = Code for Week Sealed  
L = Lot Number  
— = "Green" Packaging

Package may or may not include the following marks: Si or

12-Lead DFN

## Drain Output Diodes

Sym	Parameter	Min	Typ	Max	Unit	Condition
$V_R$	Breakdown voltage	200	-	-	V	$I_R = 100\mu A$
VF	Forward voltage	-	1.25	-	V	$I_F = 100mA$
$I_{FM}$	Park forward current	-	3.0	-	A	Pulse width = 1.0μs, D% = 1%, One diode
$I_R$	Reverse current	-	1.0	-	μA	$V_R = 100 V, T_A = 25^\circ C$
		-	100	-		$V_R = 100 V, T_A = 125^\circ C$
$t_{tr}$	Reverse recovery time	-	1.0	-	μs	$I_F = I_R = 10mA, I_{RR} = 1.0 mA, R_L = 100\Omega$

## Pin Description

Pin #	Function	Description	Pin #	Function	Description
1	GN1	Gate of N-MOSFET 1	7	DP2	Drain of P-MOSFET 2
2	GP1	Gate of P-MOSFET 1	8	DN2	Drain of N-MOSFET 2
3	GN2	Gate of N-MOSFET 2	9	SP1	Source of P-MOSFET 1
4	SN2	Source of N-MOSFET 2	10	DP1	Drain of P-MOSFET 1
5	GP2	Gate of P-MOSFET 2	11	DN1	Drain of N-MOSFET 1
6	SP2	Source of P-MOSFET 2	12	SN1	Source of N-MOSFET 1
Thermal Pad		Die attachment substrate, must be grounded externally			

**N-Channel Electrical Characteristics** ( $T_A = 25^\circ\text{C}$  unless otherwise specified)

Sym	Parameter	Min	Typ	Max	Units	Conditions
$BV_{DSS}$	Drain-to-source breakdown voltage	200	-	-	V	$V_{GS} = 0V, I_D = 2.0mA$
$V_{GS(th)}$	Gate threshold voltage	1.0	-	2.4	V	$V_{GS} = V_{DS}, I_D = 1.0mA$
$\Delta V_{GS(th)}$	Change in $V_{GS(th)}$ with temperature	-	-	-4.5	mV/°C	$V_{GS} = V_{DS}, I_D = 1.0mA$
$R_{GS}$	Gate-to-source shunt resistor	10	-	50	K $\Omega$	$I_{GS} = 100\mu A$
$VZ_{GS}$	Gate-to-source Zener voltage	13.2	-	25	V	$I_{GS} = 2.0mA$
$I_{DSS}$	Zero gate voltage drain current	-	-	10.0	$\mu A$	$V_{DS} = \text{Max rating}, V_{GS} = 0V$
		-	-	1.0	mA	$V_{DS} = 0.8 \text{ Max Rating}, V_{GS} = 0V, T_A = 125^\circ\text{C}$
$I_{D(ON)}$	On-state drain current	0.9	-	-	A	$V_{GS} = 5.0V, V_{DS} = 25V$
		2.0	-	-		$V_{GS} = 10V, V_{DS} = 50V$
$R_{DS(ON)}$	Static drain-to-source on-state resistance	-	-	13	$\Omega$	$V_{GS} = 5.0V, I_D = 150mA$
		-	-	10		$V_{GS} = 10V, I_D = 1.0A$
$\Delta R_{DS(ON)}$	Change in $R_{DS(ON)}$ with temperature	-	-	1.0	%/°C	$V_{GS} = 5.0V, I_D = 150mA$
$G_{FS}$	Forward transconductance	300	-	-	mmho	$V_{DS} = 25V, I_D = 500mA$
$C_{ISS}$	Input capacitance	-	52	-	pF	$V_{GS} = 0V, V_{DS} = 25V, f = 1.0MHz$
$C_{OSS}$	Common source output capacitance	-	6.9	-		
$C_{RSS}$	Reverse transfer capacitance	-	1.3	-		
$t_{d(ON)}$	Turn-on delay time	-	-	10	ns	$V_{DD} = 25V, I_D = 1.0A, R_{GEN} = 25\Omega$
$t_r$	Rise time	-	-	15		
$t_{d(OFF)}$	Turn-off delay time	-	-	20		
$t_f$	Fall time	-	-	15		
$V_{SD}$	Diode forward voltage drop	-	-	1.8	V	$V_{GS} = 0V, I_{SD} = 500mA$
$t_{rr}$	Reverse recovery time	-	300	-	ns	$V_{GS} = 0V, I_{SD} = 500mA$

**Notes:**

1. All D.C. parameters 100% tested at 25°C unless otherwise stated. (Pulse test: 300 $\mu s$  pulse, 2% duty cycle.)
2. All A.C. parameters sample tested.

**N-Channel Switching Waveforms and Test Circuit**

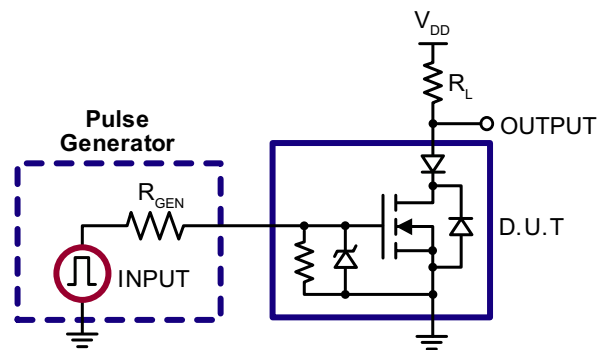
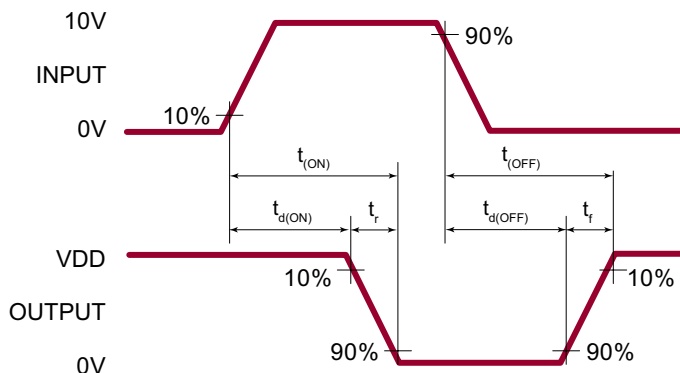

**P-Channel Electrical Characteristics** ( $T_A = 25^\circ\text{C}$  unless otherwise specified)

Sym	Parameter	Min	Typ	Max	Units	Conditions
$BV_{DSS}$	Drain-to-source breakdown voltage	-200	-	-	V	$V_{GS} = 0V, I_D = -2.0mA$
$V_{GS(th)}$	Gate threshold voltage	-1.0	-	-2.4	V	$V_{GS} = V_{DS}, I_D = -1.0mA$
$\Delta V_{GS(th)}$	Change in $V_{GS(th)}$ with temperature	-	-	4.5	mV/°C	$V_{GS} = V_{DS}, I_D = -1.0mA$
$R_{GS}$	Gate-to-source shunt resistor	10	-	50	K $\Omega$	$I_{GS} = 100\mu A$
$VZ_{GS}$	Gate-to-source Zener voltage	13.2	-	25	V	$I_{GS} = -2.0mA$
$I_{DSS}$	Zero gate voltage drain current	-	-	-10	$\mu A$	$V_{DS} = \text{Max rating}, V_{GS} = 0V$
		-	-	-1.0	mA	$V_{DS} = 0.8 \text{ Max Rating}, V_{GS} = 0V, T_A = 125^\circ\text{C}$
$I_{D(ON)}$	On-state drain current	-0.7	-	-	A	$V_{GS} = -5.0V, V_{DS} = -25V$
		-2.0	-	-		$V_{GS} = -10V, V_{DS} = -50V$
$R_{DS(ON)}$	Static drain-to-source on-state resistance	-	-	15	$\Omega$	$V_{GS} = -5.0V, I_D = -150mA$
		-	-	12		$V_{GS} = -10V, I_D = -1.0A$
$\Delta R_{DS(ON)}$	Change in $R_{DS(ON)}$ with temperature	-	-	1.0	%/°C	$V_{GS} = -10V, I_D = -200mA$
$G_{FS}$	Forward transconductance	300	-	-	mmho	$V_{DS} = -25V, I_D = -500mA$
$C_{ISS}$	Input capacitance	-	54	-	pF	$V_{GS} = 0V, V_{DS} = -25V, f = 1.0MHz$
$C_{OSS}$	Common source output capacitance	-	7.5	-		
$C_{RSS}$	Reverse transfer capacitance	-	2.6	-		
$t_{d(ON)}$	Turn-on delay time	-	-	10	ns	$V_{DD} = -25V, I_D = -1.0A, R_{GEN} = 25\Omega$
$t_r$	Rise time	-	-	15		
$t_{d(OFF)}$	Turn-off delay time	-	-	20		
$t_f$	Fall time	-	-	15		
$V_{SD}$	Diode forward voltage drop	-	-	-1.8	V	$V_{GS} = 0V, I_{SD} = -500mA$
$t_{rr}$	Reverse recovery time	-	300	-	ns	$V_{GS} = 0V, I_{SD} = -500mA$

**Notes:**

1. All D.C. parameters 100% tested at 25°C unless otherwise stated. (Pulse test: 300 $\mu s$  pulse, 2% duty cycle.)
2. All A.C. parameters sample tested.

**P-Channel Switching Waveforms and Test Circuit**

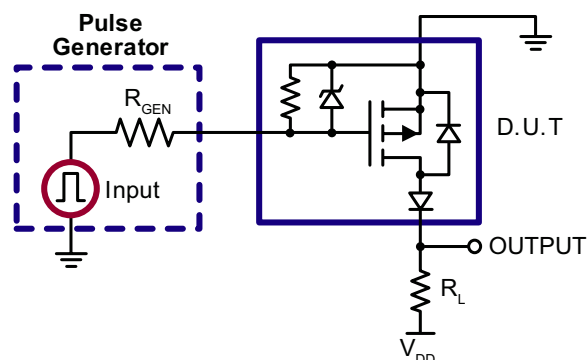
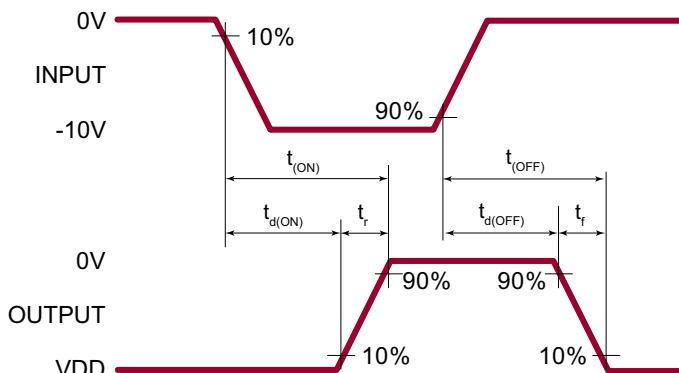

# 12-Lead DFN Package Outline (K6)

4.00x4.00mm body, 1.00mm height (max), 0.50mm pitch

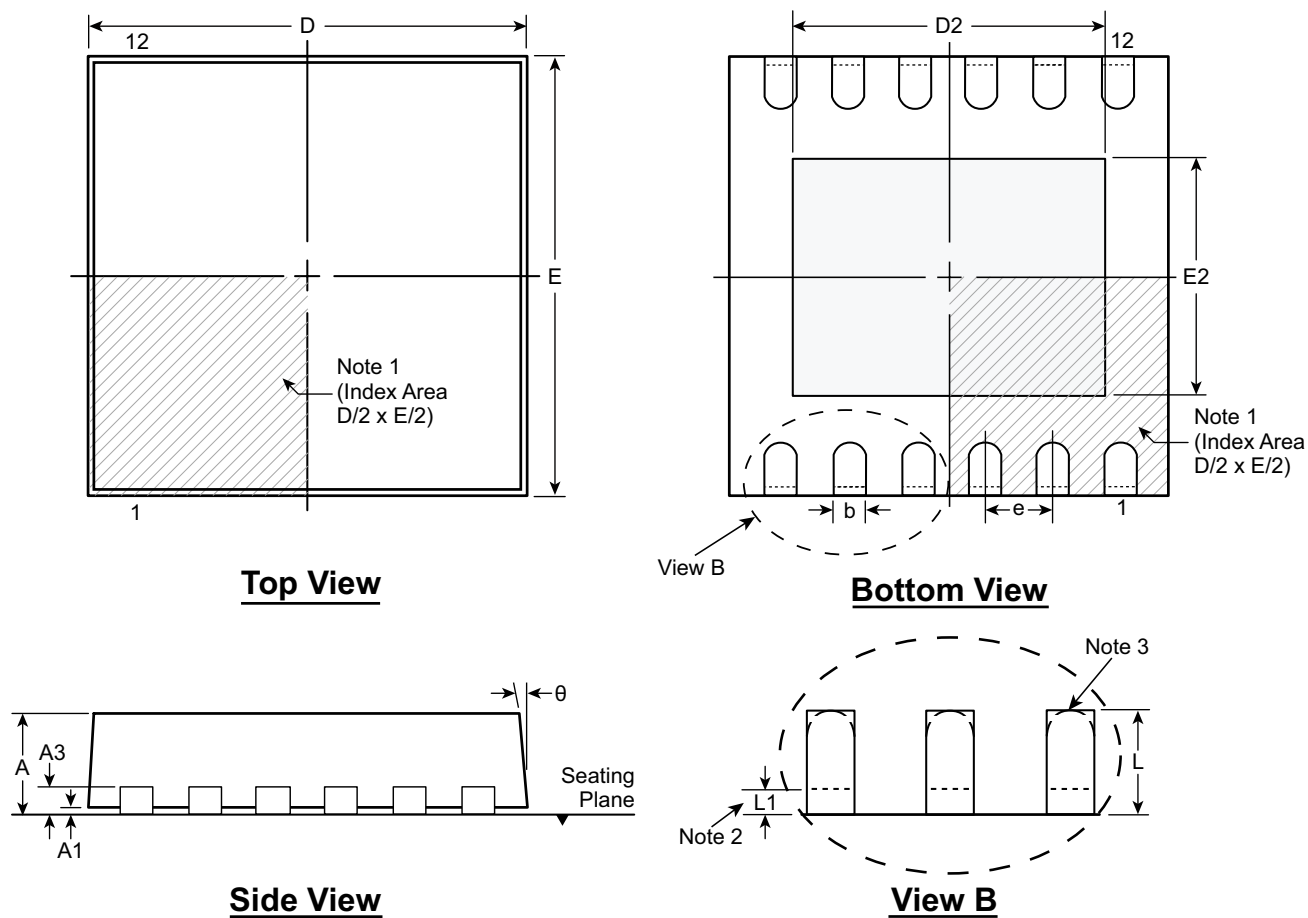

**Notes:**

1. A Pin 1 identifier must be located in the index area indicated. The Pin 1 identifier can be: a molded mark/identifier; an embedded metal marker; or a printed indicator.
2. Depending on the method of manufacturing, a maximum of 0.15mm pullback (L1) may be present.
3. The inner tip of the lead may be either rounded or square.

Symbol	A	A1	A3	b	D	D2	E	E2	e	L	L1	θ	
Dimension (mm)	MIN	0.80	0.00	0.20 REF	0.18	3.85	3.19	3.85	2.29	0.50 BSC	0.30	0.00	0°
	NOM	0.90	0.02		0.25	4.00	3.34	4.00	2.44		0.40	-	-
	MAX	1.00	0.05		0.30	4.15	3.44	4.15	2.54		0.50	0.15	14°

Drawings not to scale.

Supertex Doc.#: DSPD-12DFNK64X4P050, Version A030210.

(The package drawing(s) in this data sheet may not reflect the most current specifications. For the latest package outline information go to <http://www.supertex.com/packaging.html>.)

**Supertex inc.** does not recommend the use of its products in life support applications, and will not knowingly sell them for use in such applications unless it receives an adequate "product liability indemnification insurance agreement." **Supertex inc.** does not assume responsibility for use of devices described, and limits its liability to the replacement of the devices determined defective due to workmanship. No responsibility is assumed for possible omissions and inaccuracies. Circuitry and specifications are subject to change without notice. For the latest product specifications refer to the **Supertex inc.** (website: <http://www.supertex.com>)