

THIS DRAWING IS UNPUBLISHED. RELEASED FOR PUBLICATION NOV ,2003.
 © COPYRIGHT 2003 BY TYCO ELECTRONICS CORPORATION. ALL RIGHTS RESERVED.

| LOC | DIST | REVISIONS | | | | | |
|-----|------|-----------|-----|--------------|---------|-----|------|
| E | B | P | LTR | DESCRIPTION | DATE | DWN | APVD |
| | | B | | EBD0-0248-03 | 12NOV03 | JMS | FWK |

- 1 SINGLE PACK IN ACCORDANCE WITH SPEC 107-3275
- 2 100 TRAY PACK IN ACCORDANCE WITH SPEC 107-3275
- 3 0.76µm Au PLATING OVER 1.27µm Ni PLATING OVER 0.76µm Cu PLATING
- 4 0.08µm Au PLATING OVER 1.27µm Ni PLATING OVER 0.76µm Cu PLATING
- 5 HANDTOOL 9-1478240-0
- 6 DIE SET 9-1478248-0

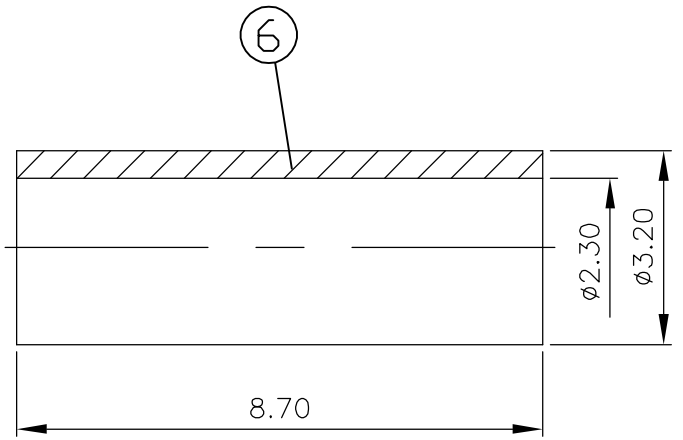
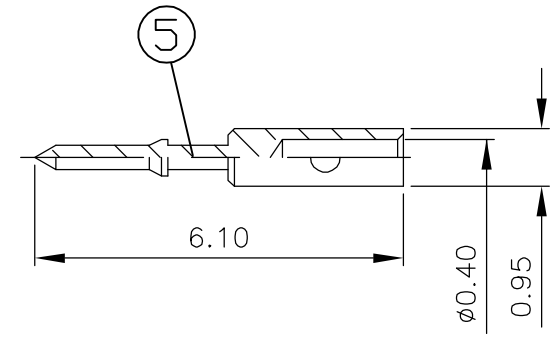
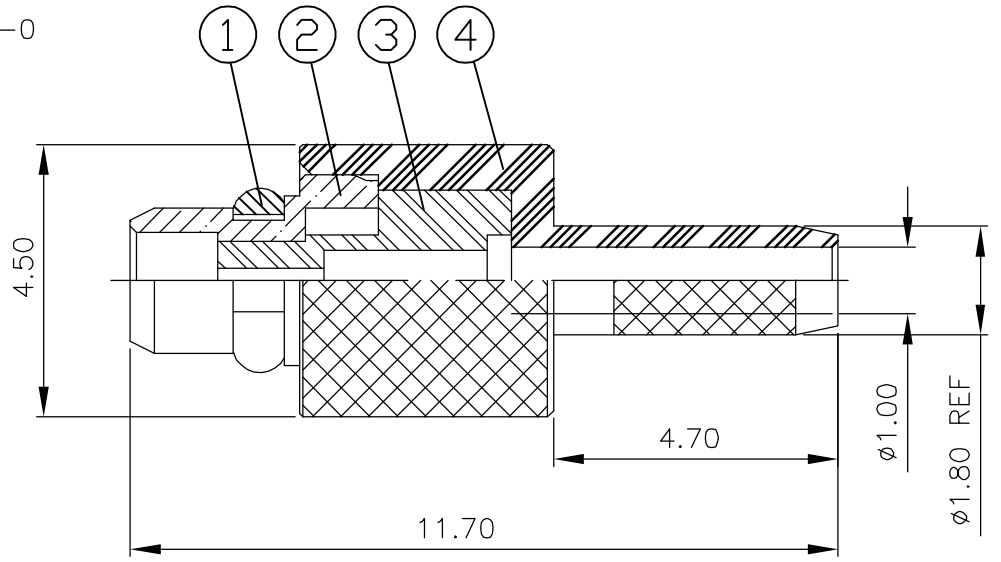

RECOMMENDED CENTRE CONTACT
A/F SQR

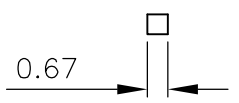

RECOMMENDED CRIMP SLEEVE
A/F HEX

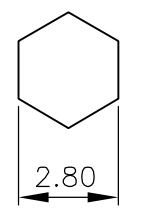

RECOMMENDED CABLE STRIPPING DIM'S

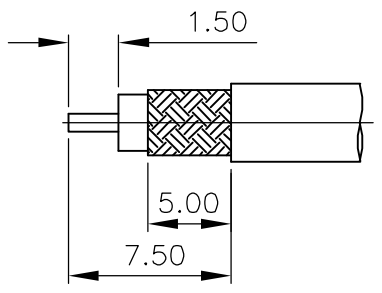

| QTY | QTY | MATERIAL | DESCRIPTION | ITEM |
|------|------|------------------|----------------|------|
| 1 | 1 | BRASS | CRIMP SLEEVE | 6 |
| 1 | 1 | BRASS | PIN | 5 |
| 1 | 1 | BRASS | BODY | 4 |
| 1 | 1 | PTFE | INSULATOR | 3 |
| 1 | 1 | BRASS | BODY | 2 |
| 1 | 1 | BERYLLIUM COPPER | RETAINING RING | 1 |
| 6--0 | 1--0 | MATERIAL | DESCRIPTION | ITEM |
| 2 | 1 | | | |

| | | | | |
|---|--|-----------------------------------|--|--------------------|
| THIS DRAWING IS A CONTROLLED DOCUMENT. | | DWN J.SANDWELL 12NOV03 | Tyco Electronics Corporation Stanmore, Middlesex, HA7 4RS | |
| DIMENSIONS: MM | | CHK S.PARLOW 12NOV03 | | |
| TOLERANCES UNLESS OTHERWISE SPECIFIED: | | APVD F.WHEELER-KING 12NOV03 | NAME MMCX STRAIGHT PLUG CRIMP RG178 50 OHMS | |
| 0 PLC ± - 1 PLC ± - 2 PLC ± - 3 PLC ± - 4 PLC ± - ANGLES ± - | | PRODUCT SPEC 108-3462 | DRAWING NO C-1634001 | |
| MATERIAL SEE TABLE | | APPLICATION SPEC 411-3278 | SIZE A3 | RESTRICTED TO - |
| FINISH SEE TABLE | | WEIGHT - | CAGE CODE 00779 | REV B |
| CUSTOMER DRAWING | | | SCALE NTS | SHEET 1 OF 1 |