

NOTES: UNLESS OTHERWISE SPECIFIED

1. All capacitor values in uF, all resistor values in ohms.
2. R5 and R6 on boards in hand are 22K, 15K in images from web.
3. Parasitic capacitances around Q1 not shown.

REVISION HISTORY			
REV	DESCRIPTION	APPROVED	DATE

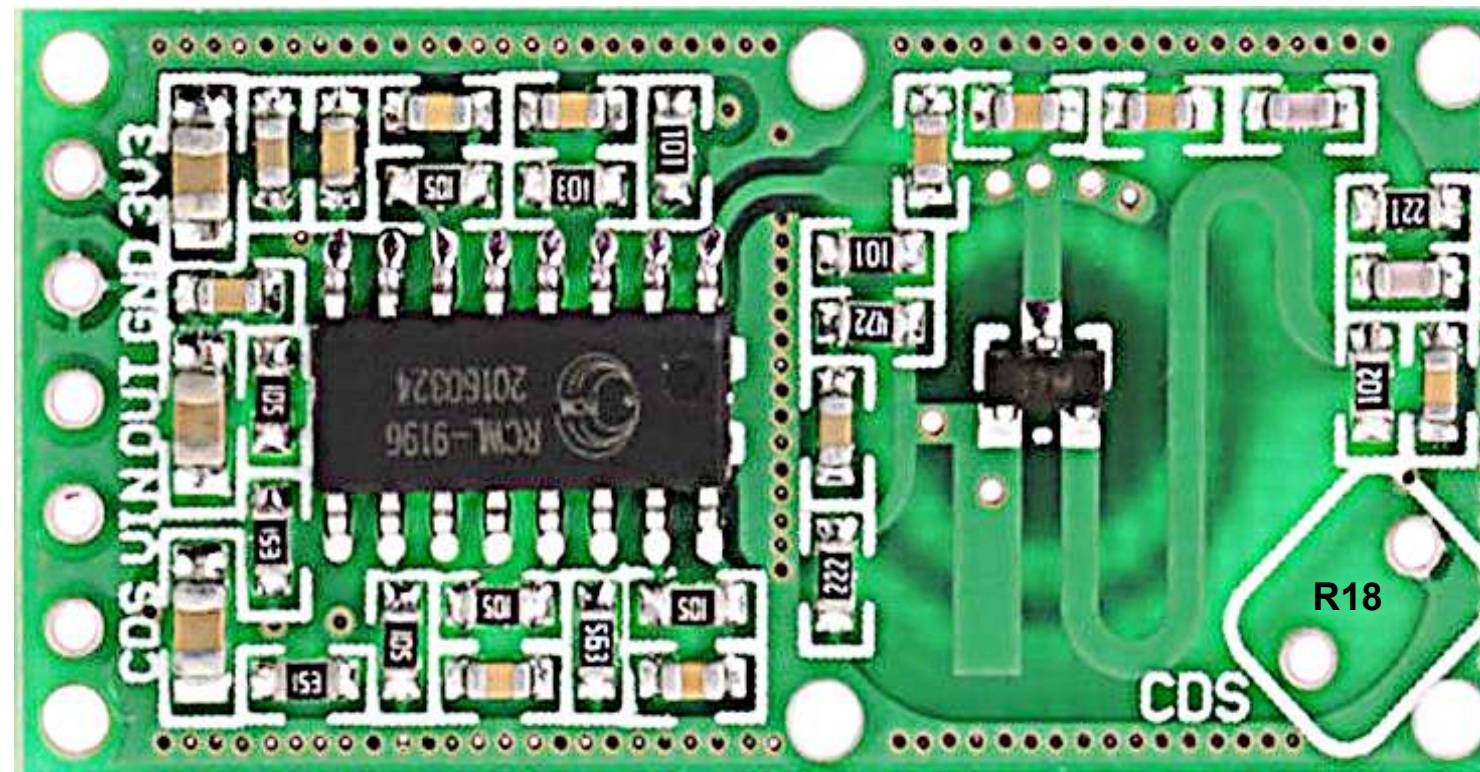
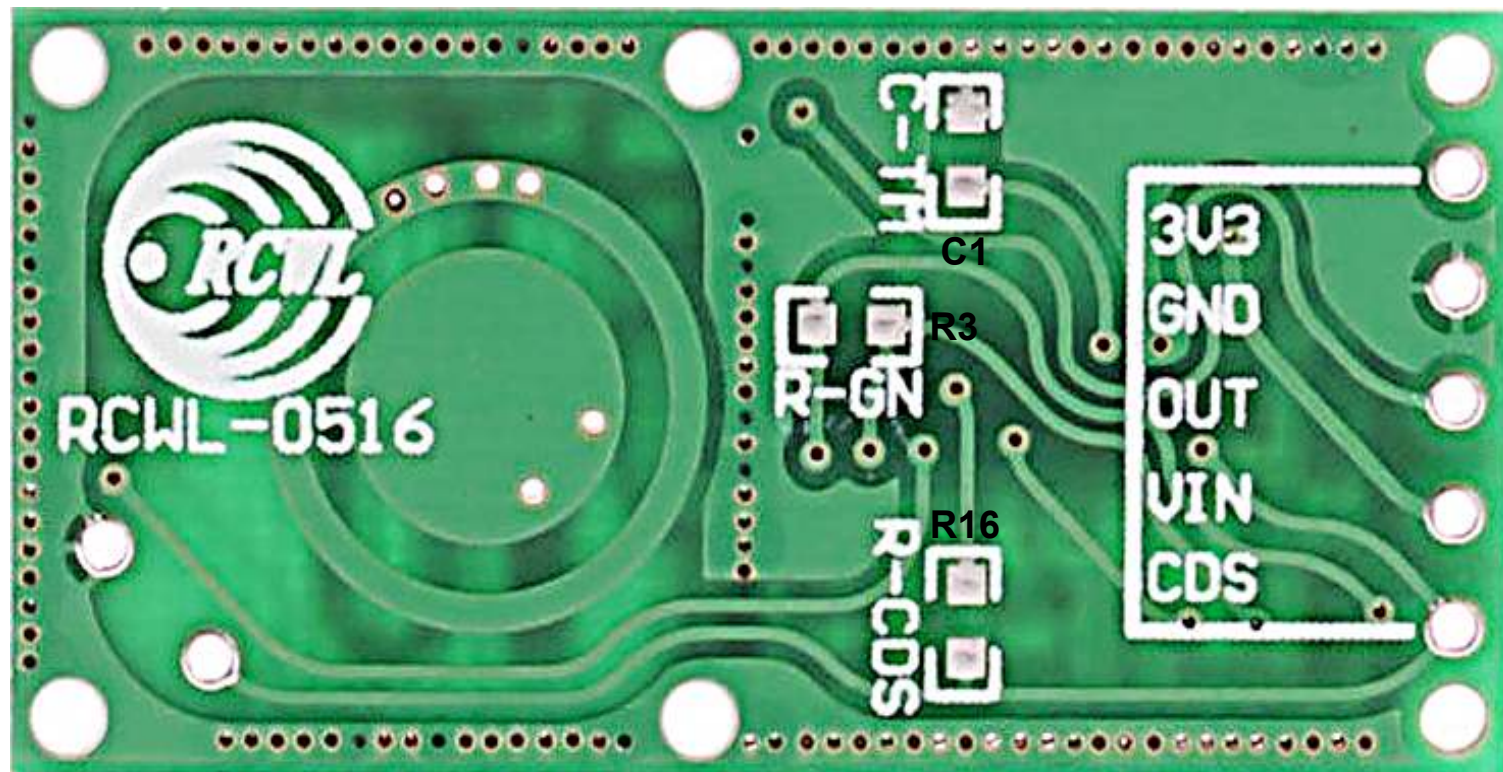
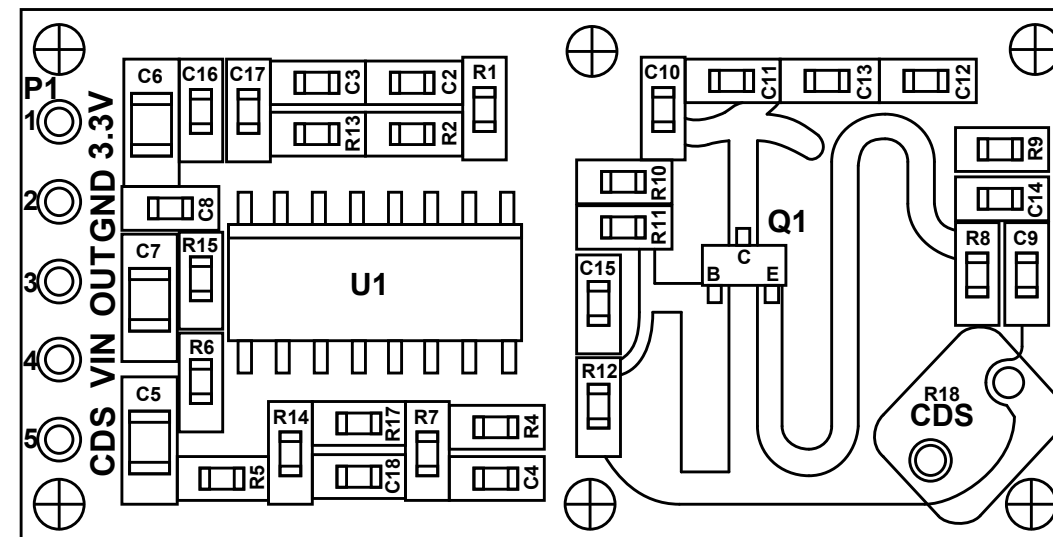
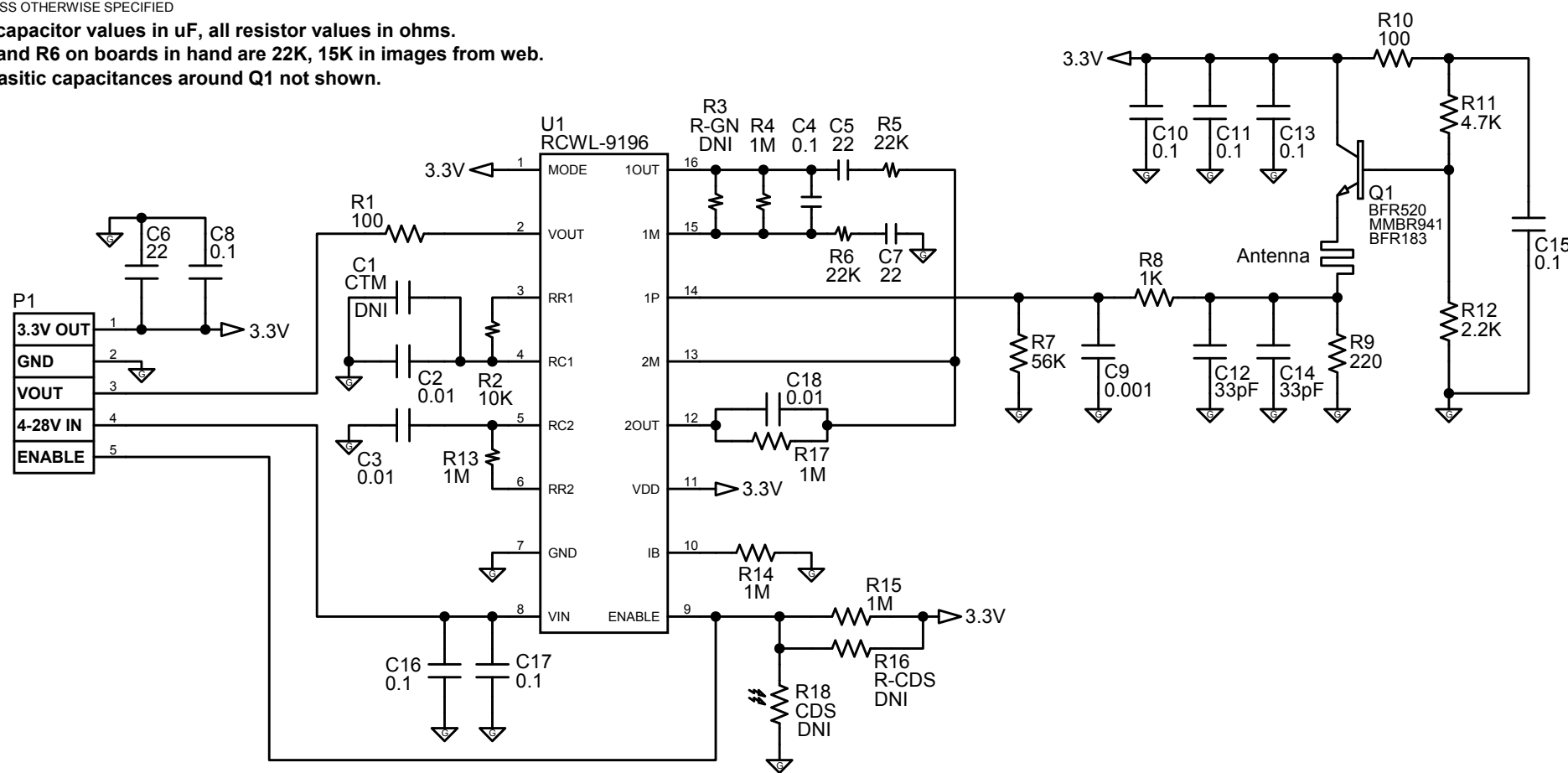

APPROVALS		DATE	TITLE	
DRAWN	J TAYLOR	2017/01/01	RCWL-0516 3.2GHz motion detector (U1 is RCWL-9196)	
CHECKED				
ENGINEER				
PROJ ENGINEER			SIZE	FSCM NO.
APPROVED			B	DRAWING NO. 0242
QA			SCALE	NONE
			© 2018 TES	MODIFIED: 01/07/18 11:28:58 AM
			SHEET	1 OF 3



REVISION HISTORY			
REV	DESCRIPTION	APPROVED	DATE

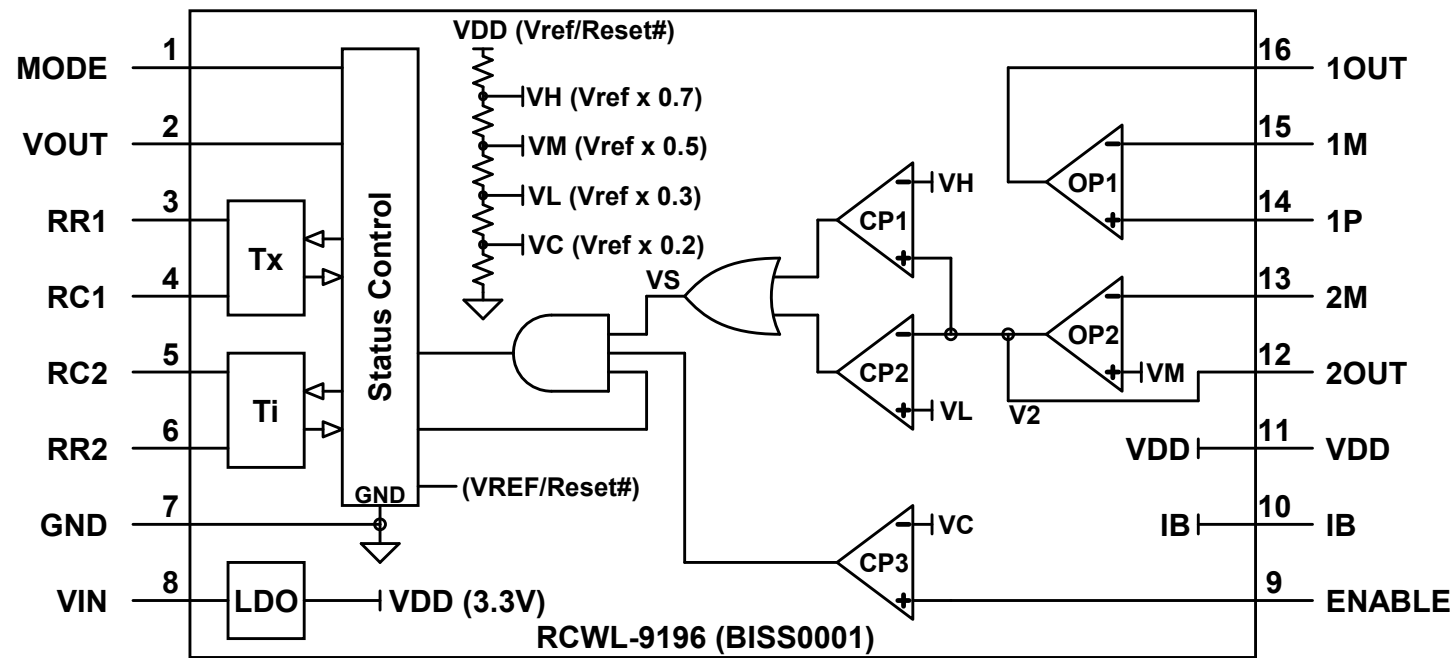

**Notes**

1. BISS0001: 8 is Vref/Reset# and 11 is VDD in (3-5V)
2. MODE: 1 = Re-triggerable, 0 = Non Re-triggerable
3. IB: Op-amp input bias current setting
4. Tx: Time VOUT remains high after triggering,  $\sim 24576 \times R \times C$
5. Ti: During this time period, triggering is inhibited,  $\sim 24 \times R \times C$

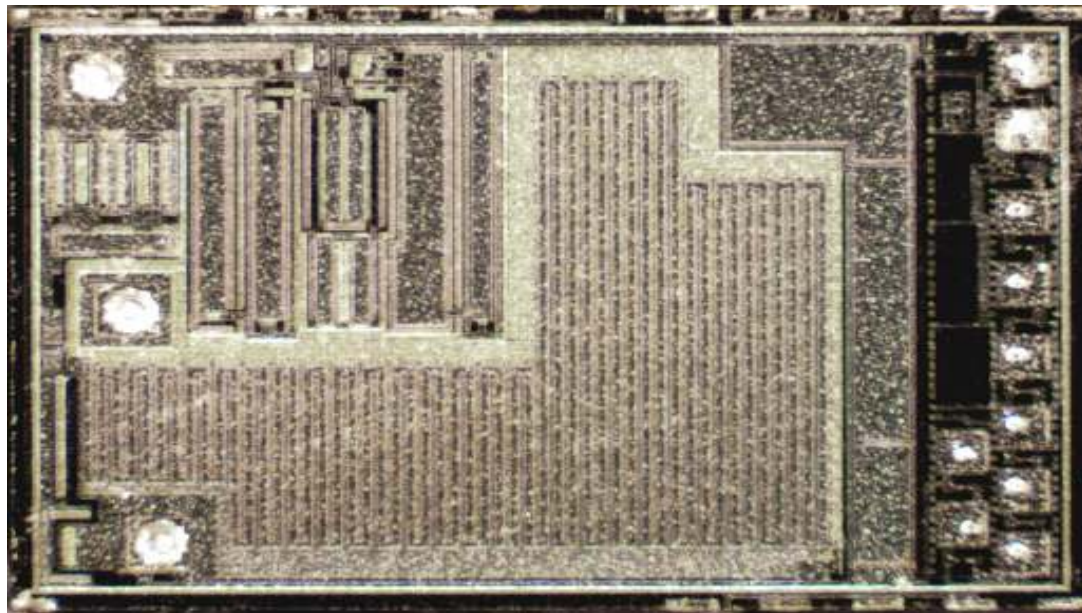

**MODE = 1 = Retriggerable**

**MODE = 0 = Non-Retriggerable**

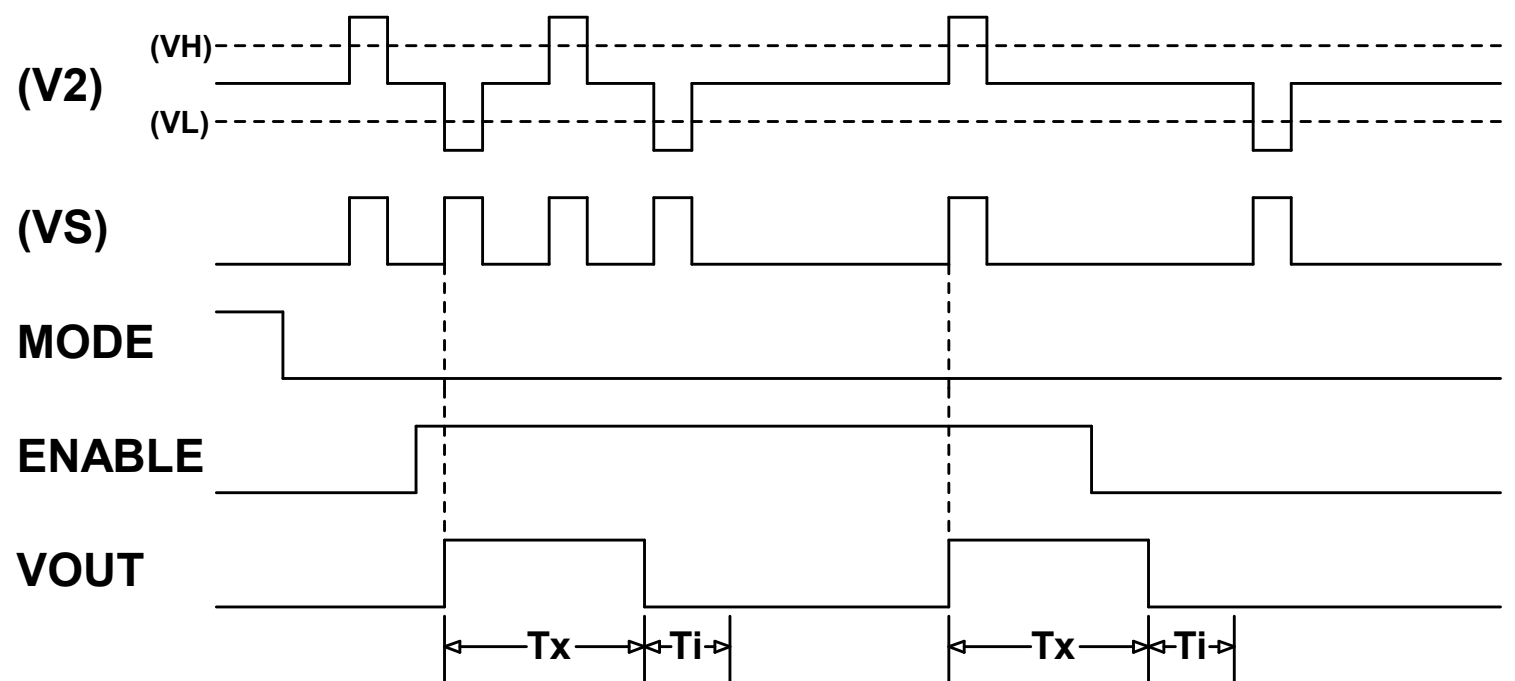
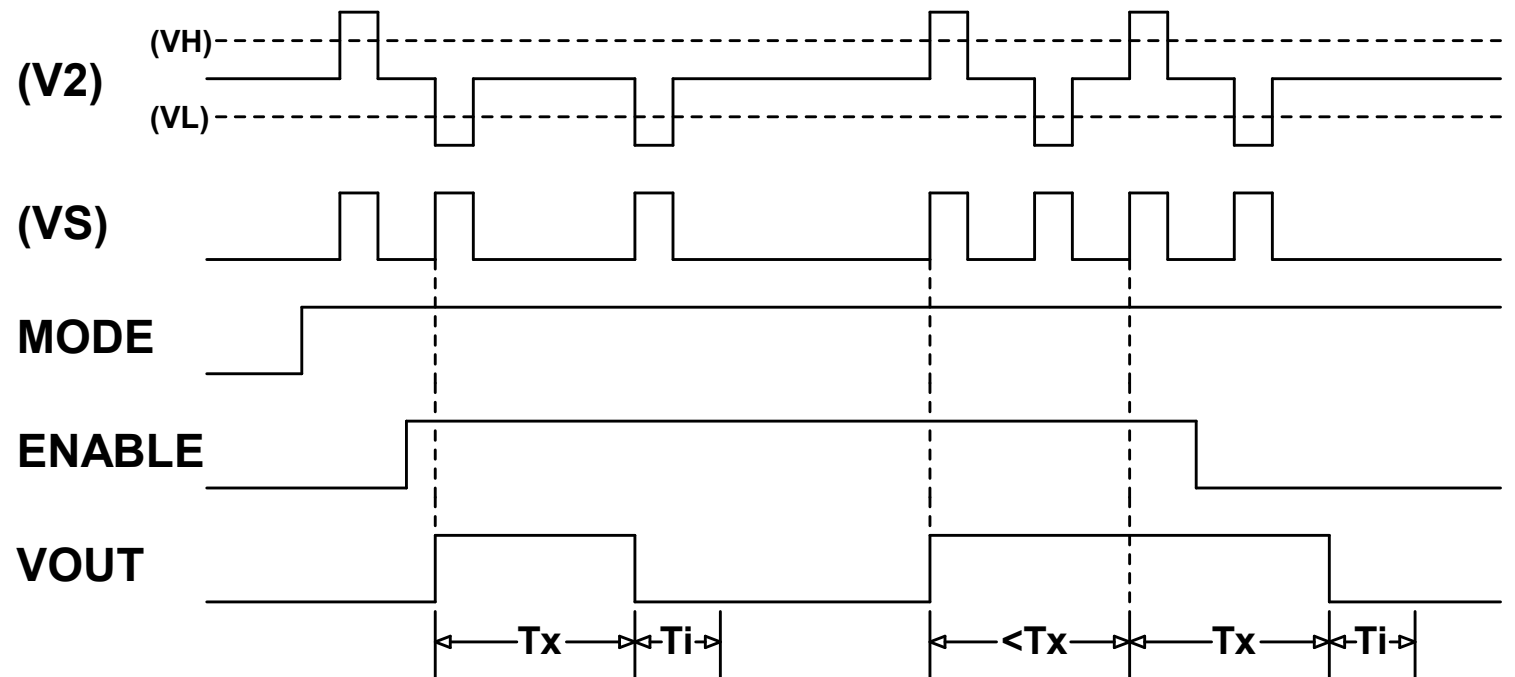

APPROVALS		DATE	TITLE		
DRAWN	J TAYLOR	2017/01/01	RCWL-0516 3.2GHz motion detector (U1 is RCWL-9196)		
CHECKED					
ENGINEER					
PROJ ENGINEER			SIZE	FSCM NO.	DRAWING NO.
APPROVED			B		0242
QA			SCALE	NONE	REV. -
			© 2018 TES	MODIFIED: 01/07/18 11:28:58 AM	SHEET 2 OF 3

REVISION HISTORY			
REV	DESCRIPTION	APPROVED	DATE

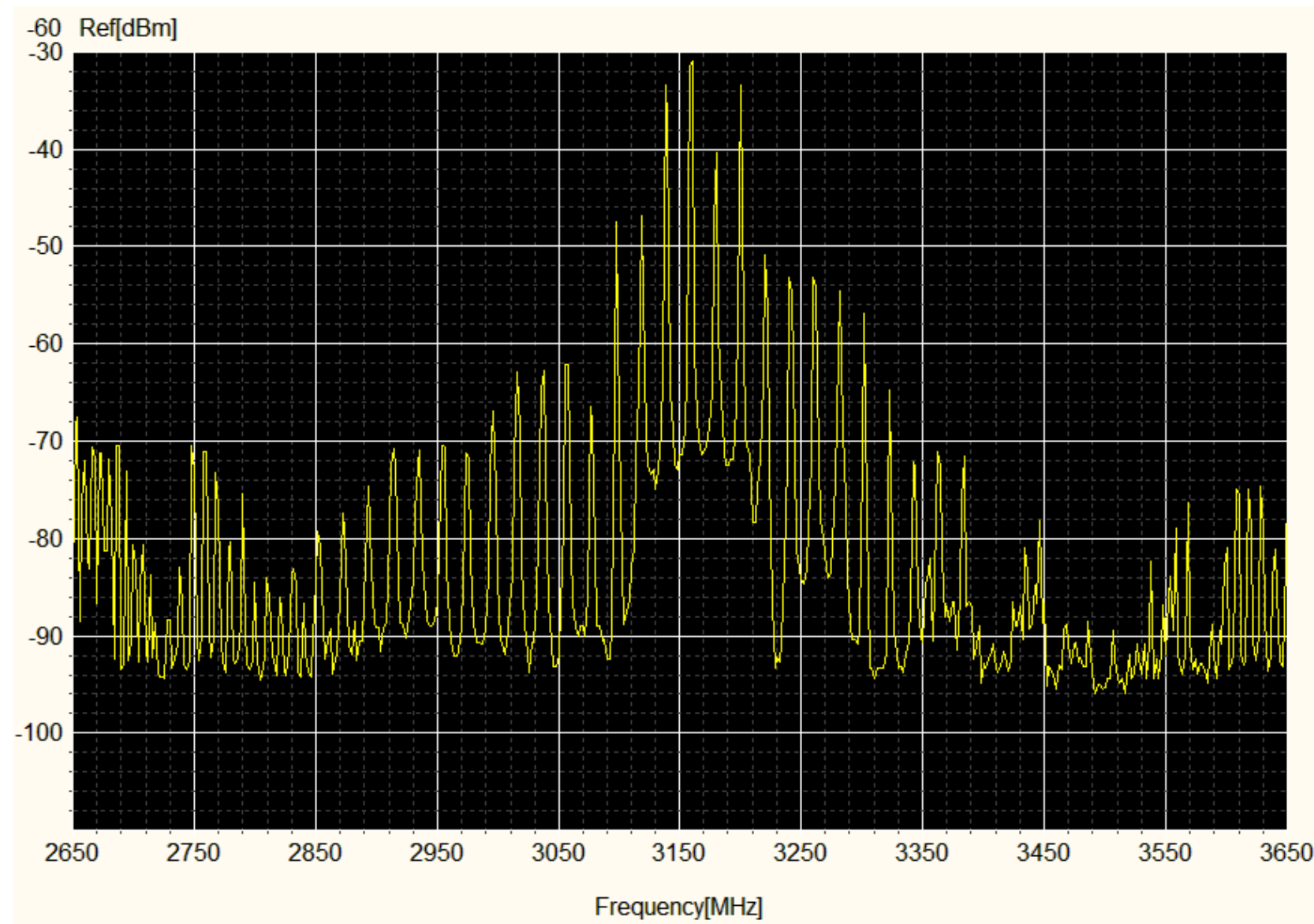

At 3175MHz, wavelength = 9.45cm  
 1/2 wavelength = 4.725cm

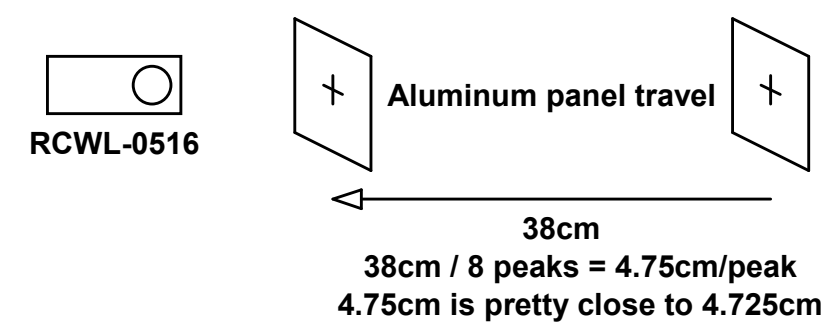
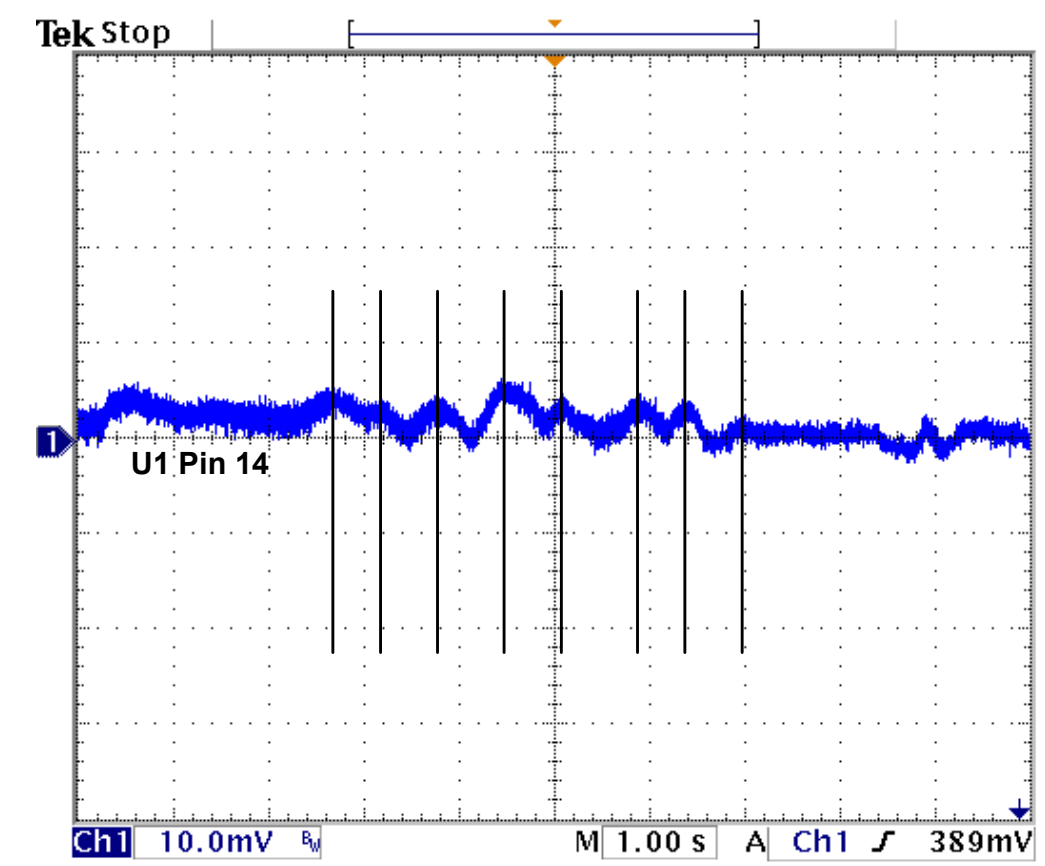

APPROVALS		DATE	TITLE		
DRAWN	J TAYLOR	2017/01/01	RCWL-0516 3.2GHz motion detector (U1 is RCWL-9196)		
CHECKED					
ENGINEER					
PROJ ENGINEER			SIZE	FSCM NO.	DRAWING NO.
APPROVED			B		0242
QA			SCALE	© 2018 TES	MODIFIED: 01/07/18 11:28:58 AM
			NONE		SHEET 3 OF 3