

74HC163; 74HCT163

Presettable synchronous 4-bit binary counter; synchronous reset

Rev. 4 — 28 December 2015

Product data sheet

1. General description

The 74HC163; 74HCT163 is a synchronous presettable binary counter with an internal look-ahead carry. Synchronous operation is provided by having all flip-flops clocked simultaneously on the positive-going edge of the clock (CP). The outputs (Q0 to Q3) of the counters may be preset to a HIGH or LOW. A LOW at the parallel enable input (\overline{PE}) disables the counting action. It causes the data at the data inputs (D0 to D3) to be loaded into the counter on the positive-going edge of the clock. Preset takes place regardless of the levels at count enable inputs (CEP and CET). A LOW at the master reset input (\overline{MR}) sets Q0 to Q3 LOW after the next positive-going transition on the clock input (CP). This action occurs regardless of the levels at input pins \overline{PE} , CET and CEP. This synchronous reset feature enables the designer to modify the maximum count with only one external NAND gate. The look-ahead carry simplifies serial cascading of the counters. Both CEP and CET must be HIGH to count. The CET input is fed forward to enable the terminal count output (TC). The TC output thus enabled will produce a HIGH output pulse of a duration approximately equal to a HIGH output of Q0. This pulse can be used to enable the next cascaded stage. Inputs include clamp diodes. This enables the use of current limiting resistors to interface inputs to voltages in excess of V_{CC} .

The CP to TC propagation delay and CEP to CP set-up time determine the maximum clock frequency for the cascaded counters according to the following formula:

$$f_{max} = \frac{1}{t_{P(max)}(CPtoTC) + t_{SU}(CEPtoCP)}$$

2. Features and benefits

- Complies with JEDEC standard no. 7A
- Input levels:
 - ◆ For 74HC163: CMOS level
 - ◆ For 74HCT163: TTL level
- Synchronous counting and loading
- 2 count enable inputs for n-bit cascading
- Synchronous reset
- Positive-edge triggered clock
- ESD protection:
 - ◆ HBM JESD22-A114F exceeds 2000 V
 - ◆ MM JESD22-A115-A exceeds 200 V
- Multiple package options
- Specified from $-40\text{ }^{\circ}\text{C}$ to $+85\text{ }^{\circ}\text{C}$ and $-40\text{ }^{\circ}\text{C}$ to $+125\text{ }^{\circ}\text{C}$



3. Ordering information

Table 1. Ordering information

Type number	Package			Version
	Temperature range	Name	Description	
74HC163D 74HCT163D	-40 °C to +125 °C	SO16	plastic small outline package; 16 leads; body width 3.9 mm	SOT109-1
74HC163DB 74HCT163DB	-40 °C to +125 °C	SSOP16	plastic shrink small outline package; 16 leads; body width 5.3 mm	SOT338-1
74HC163PW 74HCT163PW	-40 °C to +125 °C	TSSOP16	plastic thin shrink small outline package; 16 leads; body width 4.4 mm	SOT403-1

4. Functional diagram

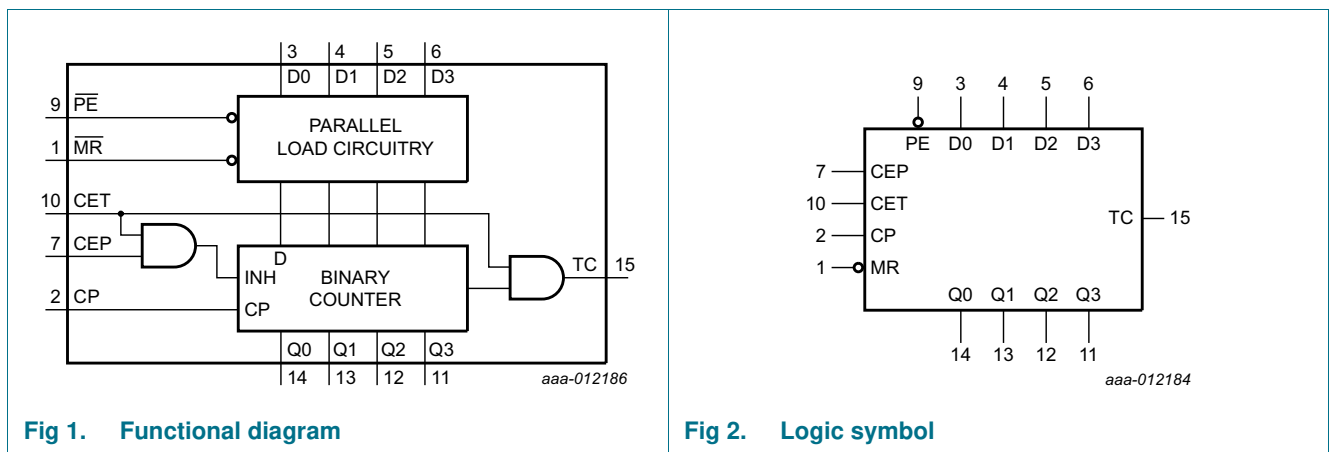

Fig 1. Functional diagram

Fig 2. Logic symbol

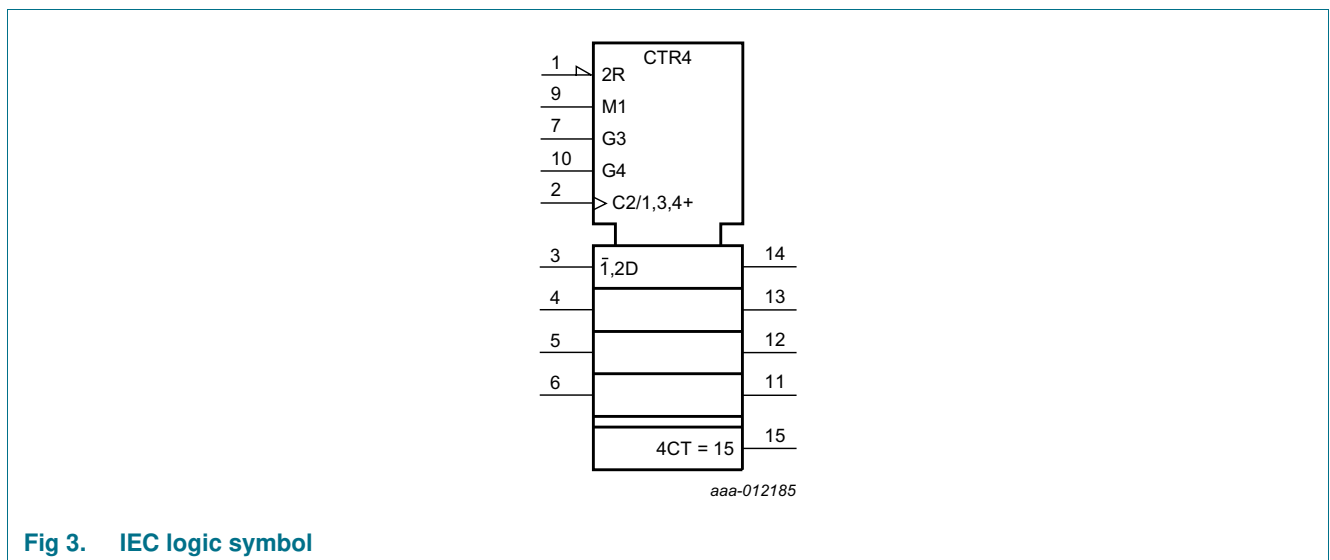

Fig 3. IEC logic symbol

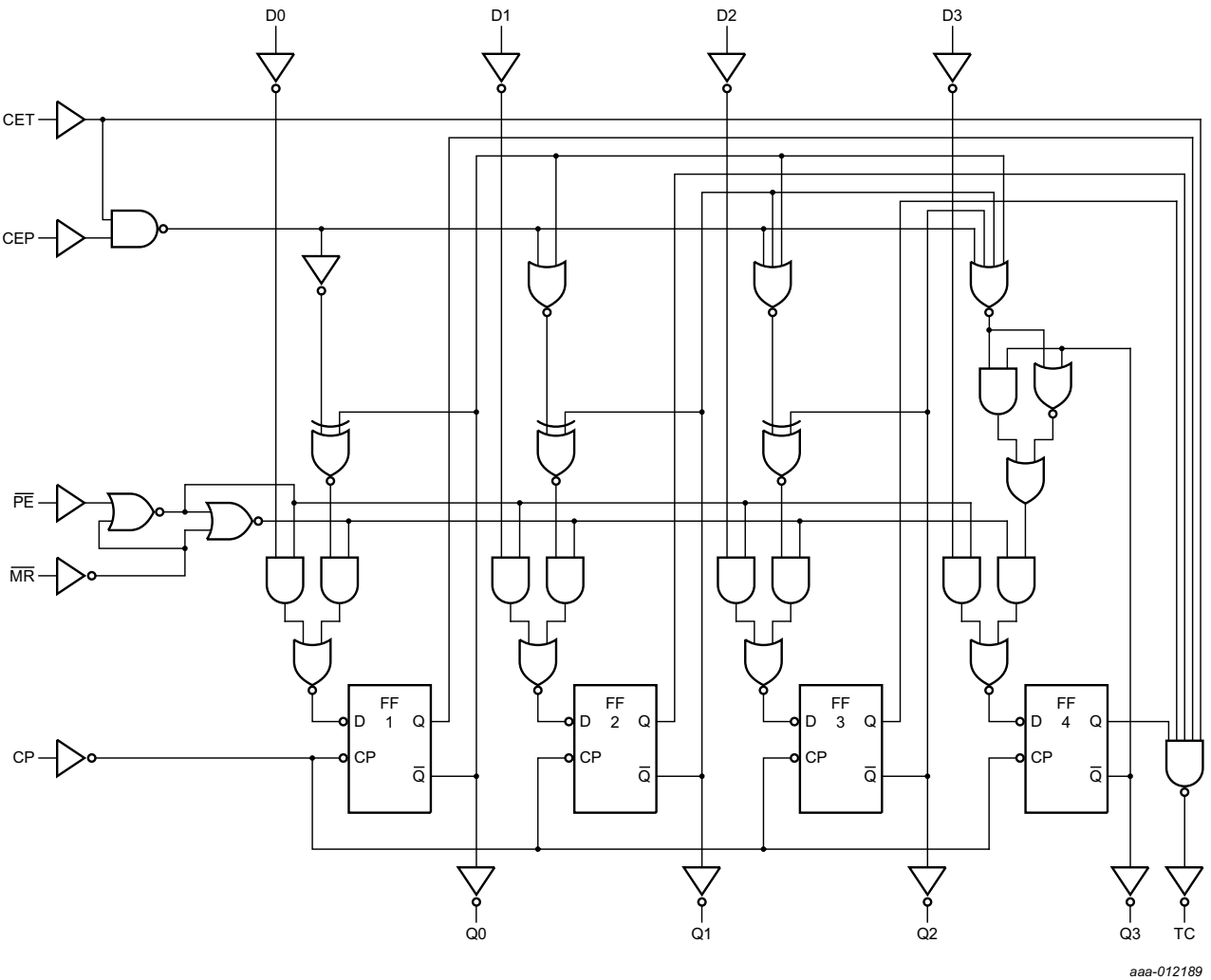
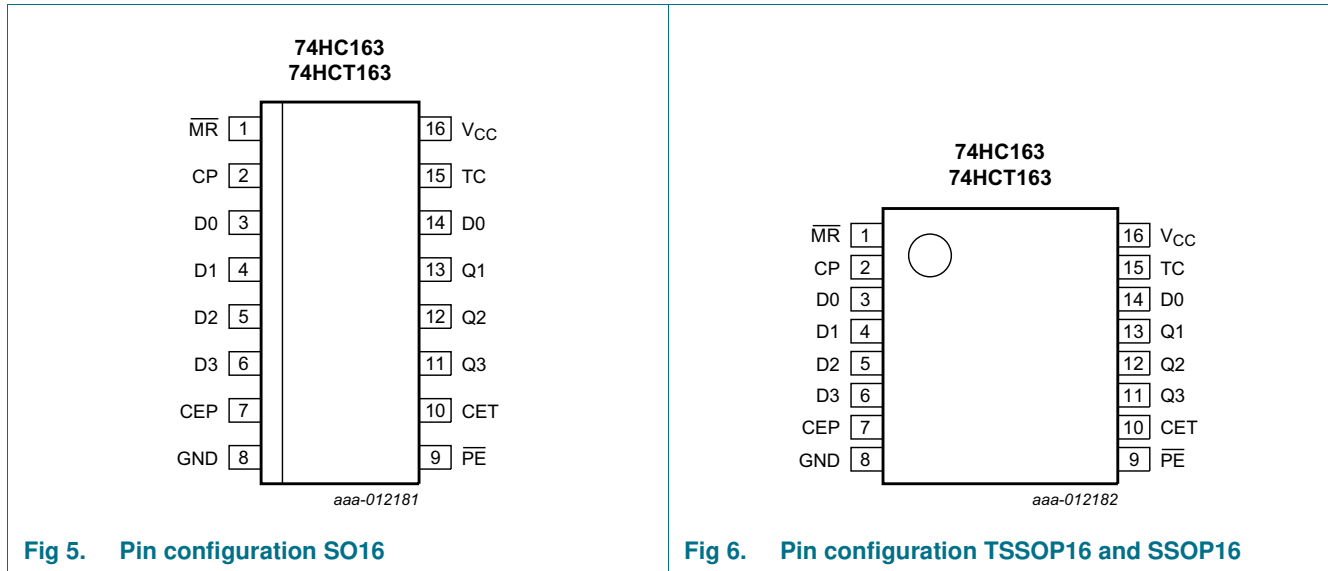

Fig 4. Logic diagram

5. Pinning information

5.1 Pinning



5.2 Pin description

Table 2. Pin description

Symbol	Pin	Description
MR	1	synchronous master reset (active LOW)
CP	2	clock input (LOW-to-HIGH, edge triggered)
D0, D1, D2, D3	3, 4, 5, 6	data input
CEP	7	count enable input
GND	8	ground (0 V)
PE	9	parallel enable input (active LOW)
CET	10	count enable carry input
Q0, Q1, Q2, Q3	14, 13, 12, 11	flip-flop output
TC	15	terminal count output
VCC	16	supply voltage

6. Functional description

Table 3. Function table^[1]

Operating mode	Inputs						Outputs	
	$\overline{\text{MR}}$	CP	CEP	CET	$\overline{\text{PE}}$	Dn	Qn	TC
Reset (clear)	l	↑	X	X	X	X	L	L
Parallel load	h	↑	X	X	l	l	L	L
	h	↑	X	X	l	h	H	L
Count	h	↑	h	h	h	X	count	
Hold (do nothing)	h	X	l	X	h	X	qn	L
	h	X	X	l	h	X	qn	L

- [1] The TC output is HIGH when CET is HIGH and the counter is at terminal count (HHHH);
 H = HIGH voltage level;
 h = HIGH voltage level one set-up time prior to the LOW-to-HIGH CP transition;
 L = LOW voltage level;
 l = LOW voltage level one set-up time prior to the LOW-to-HIGH CP transition;
 q = lower case letters indicate the state of the referenced output one set-up time prior to the LOW-to-HIGH CP transition;
 X = don't care;
 ↑ = LOW-to-HIGH clock transition.

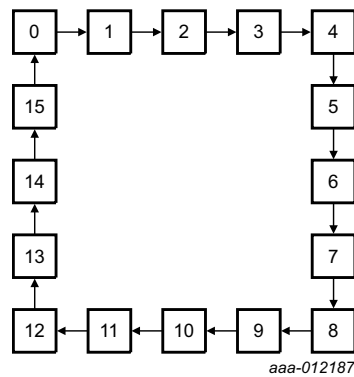
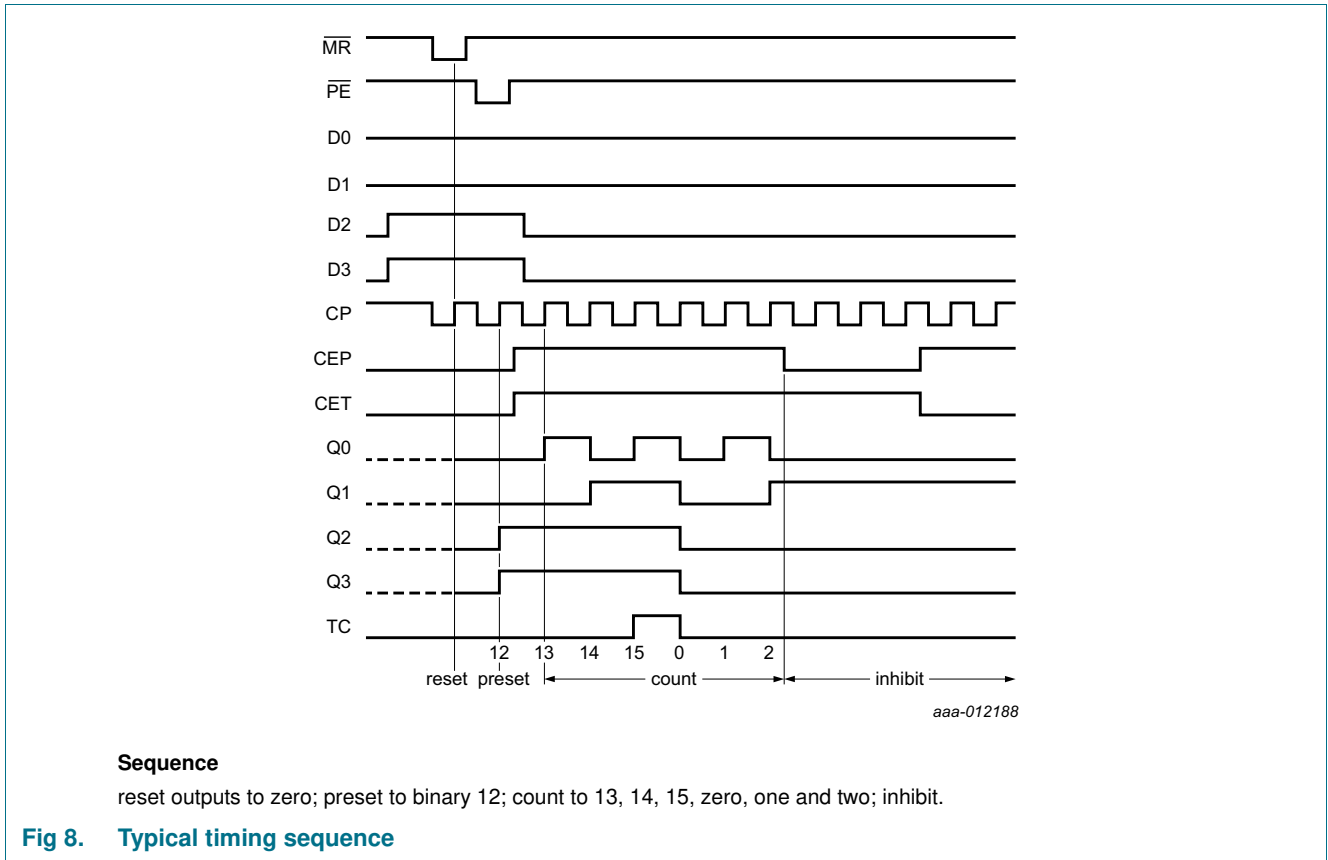

Fig 7. State diagram



7. Limiting values

Table 4. Limiting values

In accordance with the Absolute Maximum Rating System (IEC 60134). Voltages are referenced to GND (ground = 0 V).

Symbol	Parameter	Conditions	Min	Max	Unit
V_{CC}	supply voltage		-0.5	+7.0	V
I_{IK}	input clamping current	$V_I < -0.5\text{ V}$ or $V_I > V_{CC} + 0.5\text{ V}$	-	± 20	mA
I_{OK}	output clamping current	$V_O < -0.5\text{ V}$ or $V_O > V_{CC} + 0.5\text{ V}$	-	± 20	mA
I_O	output current	$V_O = -0.5\text{ V}$ to $V_{CC} + 0.5\text{ V}$	-	± 25	mA
I_{CC}	supply current		-	50	mA
I_{GND}	ground current		-50	-	mA
T_{stg}	storage temperature		-65	+150	°C
P_{tot}	total power dissipation	SO16 package [1]	-	500	mW
		(T)SSOP16 package [1]	-	500	mW

[1] For SO16 packages: above 70 °C the value of P_{tot} derates linearly at 8 mW/K.
 For (T)SSOP16 packages: above 60 °C the value of P_{tot} derates linearly at 5.5 mW/K.

8. Recommended operating conditions

Table 5. Recommended operating conditions

Voltages are referenced to GND (ground = 0 V)

Symbol	Parameter	Conditions	74HC163			74HCT163			Unit
			Min	Typ	Max	Min	Typ	Max	
V _{CC}	supply voltage		2.0	5.0	6.0	4.5	5.0	5.5	V
V _I	input voltage		0	-	V _{CC}	0	-	V _{CC}	V
V _O	output voltage		0	-	V _{CC}	0	-	V _{CC}	V
T _{amb}	ambient temperature		-40	+25	+125	-40	+25	+125	°C
Δt/ΔV	input transition rise and fall rate	V _{CC} = 2.0 V	-	-	625	-	-	-	ns/V
		V _{CC} = 4.5 V	-	1.67	139	-	1.67	139	ns/V
		V _{CC} = 6.0 V	-	-	83	-	-	-	ns/V

9. Static characteristics

Table 6. Static characteristics

At recommended operating conditions; voltages are referenced to GND (ground = 0 V).

Symbol	Parameter	Conditions	25 °C			-40 °C to +85 °C		-40 °C to +125 °C		Unit
			Min	Typ	Max	Min	Max	Min	Max	
74HC163										
V _{IH}	HIGH-level input voltage	V _{CC} = 2.0 V	1.5	1.2	-	1.5	-	1.5	-	V
		V _{CC} = 4.5 V	3.15	2.4	-	3.15	-	3.15	-	V
		V _{CC} = 6.0 V	4.2	3.2	-	4.2	-	4.2	-	V
V _{IL}	LOW-level input voltage	V _{CC} = 2.0 V	-	0.8	0.5	-	0.5	-	0.5	V
		V _{CC} = 4.5 V	-	2.1	1.35	-	1.35	-	1.35	V
		V _{CC} = 6.0 V	-	2.8	1.8	-	1.8	-	1.8	V
V _{OH}	HIGH-level output voltage	V _I = V _{IH} or V _{IL}								
		I _O = -20 μA; V _{CC} = 2.0 V	1.9	2.0	-	1.9	-	1.9	-	V
		I _O = -20 μA; V _{CC} = 4.5 V	4.4	4.5	-	4.4	-	4.4	-	V
		I _O = -20 μA; V _{CC} = 6.0 V	5.9	6.0	-	5.9	-	5.9	-	V
		I _O = -4.0; V _{CC} = 4.5 V	3.98	4.32	-	3.84	-	3.7	-	V
V _{OL}	LOW-level output voltage	V _I = V _{IH} or V _{IL}								
		I _O = 20 μA; V _{CC} = 2.0 V	-	0	0.1	-	0.1	-	0.1	V
		I _O = 20 μA; V _{CC} = 4.5 V	-	0	0.1	-	0.1	-	0.1	V
		I _O = 20 μA; V _{CC} = 6.0 V	-	0	0.1	-	0.1	-	0.1	V
		I _O = 4.0 mA; V _{CC} = 4.5 V	-	0.15	0.26	-	0.33	-	0.4	V
I _I	input leakage current	V _I = V _{CC} or GND; V _{CC} = 6.0 V	-	-	±0.1	-	±1.0	-	±1.0	μA
		V _I = V _{CC} or GND; I _O = 0 A; V _{CC} = 6.0 V	-	-	8.0	-	80.0	-	160.0	μA

Table 6. Static characteristics ...continued

At recommended operating conditions; voltages are referenced to GND (ground = 0 V).

Symbol	Parameter	Conditions	25 °C			–40 °C to +85 °C		–40 °C to +125 °C		Unit
			Min	Typ	Max	Min	Max	Min	Max	
C _I	input capacitance		-	3.5	-	-	-	-	-	pF
74HCT163										
V _{IH}	HIGH-level input voltage	V _{CC} = 4.5 V to 5.5 V	2.0	1.6	-	2.0	-	2.0	-	V
V _{IL}	LOW-level input voltage	V _{CC} = 4.5 V to 5.5 V	-	1.2	0.8	-	0.8	-	0.8	V
V _{OH}	HIGH-level output voltage	V _I = V _{IH} or V _{IL} ; V _{CC} = 4.5 V								
		I _O = –20 µA	4.4	4.5	-	4.4	-	4.4	-	V
		I _O = –4.0 mA	3.98	4.32	-	3.84	-	3.7	-	V
V _{OL}	LOW-level output voltage	V _I = V _{IH} or V _{IL} ; V _{CC} = 4.5 V								
		I _O = 20 µA	-	0	0.1	-	0.1	-	0.1	V
		I _O = 4.0 mA	-	0.15	0.26	-	0.33	-	0.4	V
I _I	input leakage current	V _I = V _{CC} or GND; V _{CC} = 5.5 V	-	-	±0.1	-	±1.0	-	±1.0	µA
I _{CC}	supply current	V _I = V _{CC} or GND; I _O = 0 A; V _{CC} = 5.5 V	-	-	8.0	-	80.0	-	160.0	µA
ΔI _{CC}	additional supply current	per input pin; V _I = V _{CC} – 2.1 V; other inputs at V _{CC} or GND; V _{CC} = 4.5 V to 5.5 V; I _O = 0 A								
		pin \overline{MR}	-	95	342	-	427.5	-	465.5	µA
		pin CP	-	110	396	-	495	-	539	µA
		pin CEP and Dn	-	25	90	-	112.5	-	122.5	µA
		pin CET	-	75	270	-	337.5	-	367.5	µA
pin \overline{PE}	-	30	108	-	135	-	147	µA		
C _I	input capacitance		-	3.5	-	-	-	-	-	pF

10. Dynamic characteristics

Table 7. Dynamic characteristics

Voltages are referenced to GND (ground = 0 V); $C_L = 50$ pF unless otherwise specified; for test circuit see [Figure 14](#).

Symbol	Parameter	Conditions	25 °C			-40 °C to +85 °C		-40 °C to +125 °C		Unit
			Min	Typ	Max	Min	Max	Min	Max	
74HC163										
t_{pd}	propagation delay	CP to Qn; see Figure 9 ^[1]								
		$V_{CC} = 2.0$ V	-	55	185	-	230	-	280	ns
		$V_{CC} = 4.5$ V	-	20	37	-	46	-	56	ns
		$V_{CC} = 5.0$ V; $C_L = 15$ pF	-	17	-	-	-	-	-	ns
		$V_{CC} = 6.0$ V	-	16	31	-	39	-	48	ns
		CP to TC; see Figure 9								
		$V_{CC} = 2.0$ V	-	69	215	-	270	-	320	ns
		$V_{CC} = 4.5$ V	-	25	43	-	54	-	65	ns
		$V_{CC} = 5.0$ V; $C_L = 15$ pF	-	21	-	-	-	-	-	ns
		$V_{CC} = 6.0$ V	-	20	37	-	46	-	55	ns
		CET to TC; see Figure 10								
		$V_{CC} = 2.0$ V	-	36	120	-	150	-	180	ns
		$V_{CC} = 4.5$ V	-	13	24	-	30	-	36	ns
$V_{CC} = 5.0$ V; $C_L = 15$ pF	-	11	-	-	-	-	-	ns		
$V_{CC} = 6.0$ V	-	10	20	-	26	-	31	ns		
t_t	transition time	see Figure 9 and Figure 10 ^[2]								
		$V_{CC} = 2.0$ V	-	19	75	-	95	-	110	ns
		$V_{CC} = 4.5$ V	-	7	15	-	19	-	22	ns
		$V_{CC} = 6.0$ V	-	6	13	-	16	-	19	ns
t_w	pulse width	CP; HIGH or LOW; see Figure 9								
		$V_{CC} = 2.0$ V	80	17	-	100	-	120	-	ns
		$V_{CC} = 4.5$ V	16	6	-	20	-	24	-	ns
		$V_{CC} = 6.0$ V	14	5	-	17	-	20	-	ns

Table 7. Dynamic characteristics ...continued

Voltages are referenced to GND (ground = 0 V); C_L = 50 pF unless otherwise specified; for test circuit see [Figure 14](#).

Symbol	Parameter	Conditions	25 °C			-40 °C to +85 °C		-40 °C to +125 °C		Unit
			Min	Typ	Max	Min	Max	Min	Max	
t _{su}	set-up time	$\overline{\text{MR}}$, Dn to CP; see Figure 11 and Figure 12								
		V _{CC} = 2.0 V	80	17	-	100	-	120	-	ns
		V _{CC} = 4.5 V	16	6	-	20	-	24	-	ns
		V _{CC} = 6.0 V	14	5	-	17	-	20	-	ns
		$\overline{\text{PE}}$ to CP; see Figure 11								
		V _{CC} = 2.0 V	80	22	-	100	-	120	-	ns
		V _{CC} = 4.5 V	16	8	-	20	-	24	-	ns
		V _{CC} = 6.0 V	14	6	-	17	-	20	-	ns
		CEP, CET to CP; see Figure 13								
		V _{CC} = 2.0 V	175	58	-	220	-	265	-	ns
V _{CC} = 4.5 V	35	21	-	44	-	53	-	ns		
V _{CC} = 6.0 V	30	17	-	37	-	45	-	ns		
t _h	hold time	Dn, $\overline{\text{PE}}$, CEP, CET, $\overline{\text{MR}}$ to CP; see Figure 11 , Figure 12 and Figure 13								
		V _{CC} = 2.0 V	0	-14	-	0	-	0	-	ns
		V _{CC} = 4.5 V	0	-5	-	0	-	0	-	ns
		V _{CC} = 6.0 V	0	-4	-	0	-	0	-	ns
f _{max}	maximum frequency	CP; see Figure 9								
		V _{CC} = 2.0 V	5	15	-	4	-	4	-	MHz
		V _{CC} = 4.5 V	27	46	-	22	-	18	-	MHz
		V _{CC} = 5.0 V; C _L = 15 pF	-	51	-	-	-	-	-	MHz
		V _{CC} = 6.0 V	32	55	-	26	-	21	-	MHz
C _{PD}	power dissipation capacitance	V _I = GND to V _{CC} ; V _{CC} = 5 V; f _i = 1 MHz [3]	-	33	-	-	-	-	-	pF

Table 7. Dynamic characteristics ...continued

Voltages are referenced to GND (ground = 0 V); $C_L = 50$ pF unless otherwise specified; for test circuit see [Figure 14](#).

Symbol	Parameter	Conditions	25 °C			-40 °C to +85 °C		-40 °C to +125 °C		Unit
			Min	Typ	Max	Min	Max	Min	Max	
74HCT193										
t_{pd}	propagation delay	CP to Qn; see Figure 9 ^[1]	-							
		$V_{CC} = 4.5$ V	-	23	39	-	49	-	59	ns
		$V_{CC} = 5.0$ V; $C_L = 15$ pF	-	20	-	-	-	-	-	ns
		CP to TC; see Figure 9								
		$V_{CC} = 4.5$ V	-	29	49	-	61	-	74	ns
		$V_{CC} = 5.0$ V; $C_L = 15$ pF	-	25	-	-	-	-	-	ns
		CET to TC; see Figure 10								
		$V_{CC} = 4.5$ V	-	17	32	-	44	-	48	ns
		$V_{CC} = 5.0$ V; $C_L = 15$ pF	-	14	-	-	-	-	-	ns
t_t	transition time	see Figure 9 and Figure 10 ^[2]								
		$V_{CC} = 4.5$ V	-	7	15	-	19	-	22	ns
t_w	pulse width	CP; HIGH or LOW; see Figure 9								
		$V_{CC} = 4.5$ V	20	6	-	25	-	30	-	ns
t_{su}	set-up time	\overline{MR} , Dn to CP; see Figure 11 and Figure 12								
		$V_{CC} = 4.5$ V	20	9	-	25	-	30	-	ns
		\overline{PE} to CP; see Figure 11								
		$V_{CC} = 4.5$ V	20	11	-	25	-	30	-	ns
		CEP, CET to CP; see Figure 13								
		$V_{CC} = 4.5$ V	40	24	-	50	-	60	-	ns
t_h	hold time	Dn, \overline{PE} , CEP, CET, \overline{MR} to CP; see Figure 11 , Figure 12 and Figure 13								
		$V_{CC} = 4.5$ V	0	-5	-	0	-	0	-	ns
f_{max}	maximum frequency	CP; see Figure 9								
		$V_{CC} = 4.5$ V	26	45	-	21	-	17	-	MHz
		$V_{CC} = 5.0$ V; $C_L = 15$ pF	-	50	-	-	-	-	-	MHz

Table 7. Dynamic characteristics ...continued

Voltages are referenced to GND (ground = 0 V); C_L = 50 pF unless otherwise specified; for test circuit see Figure 14.

Symbol	Parameter	Conditions	25 °C			-40 °C to +85 °C		-40 °C to +125 °C		Unit
			Min	Typ	Max	Min	Max	Min	Max	
C _{PD}	power dissipation capacitance	V _I = GND to V _{CC} - 1.5 V; V _{CC} = 5 V; f _i = 1 MHz	3	-	35	-	-	-	-	pF

[1] t_{pd} is the same as t_{PHL} and t_{PLH}.

[2] t_i is the same as t_{THL} and t_{TLH}.

[3] C_{PD} is used to determine the dynamic power dissipation (P_D in μW):

$$P_D = C_{PD} \times V_{CC}^2 \times f_i \times N + \sum(C_L \times V_{CC}^2 \times f_o) \text{ where:}$$

f_i = input frequency in MHz;

f_o = output frequency in MHz;

C_L = output load capacitance in pF;

V_{CC} = supply voltage in V;

N = number of inputs switching;

∑(C_L × V_{CC}² × f_o) = sum of outputs.

11. Waveforms

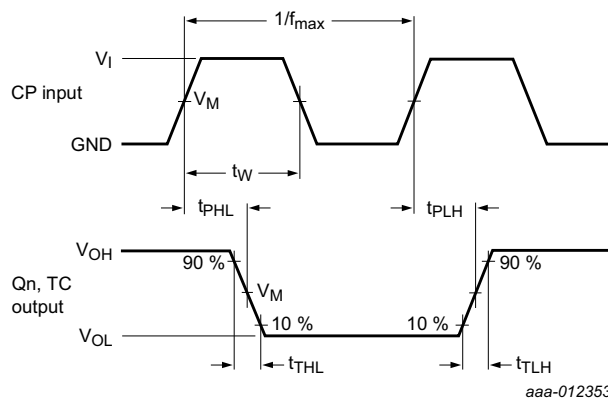

Measurement points are given in Table 8.

Logic levels V_{OL} and V_{OH} are typical output voltage levels that occur with the output load.

Fig 9. The clock (CP) to outputs (Qn, TC) propagation delays, pulse width, output transition times and maximum frequency

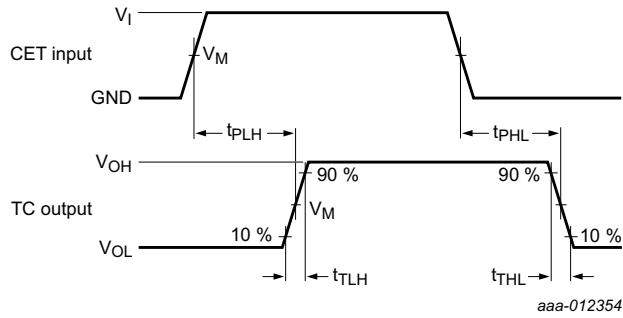

Measurement points are given in [Table 8](#).

Logic levels V_{OL} and V_{OH} are typical output voltage levels that occur with the output load.

Fig 10. The count enable carry input (CET) to terminal count output (TC) propagation delays and output transition times

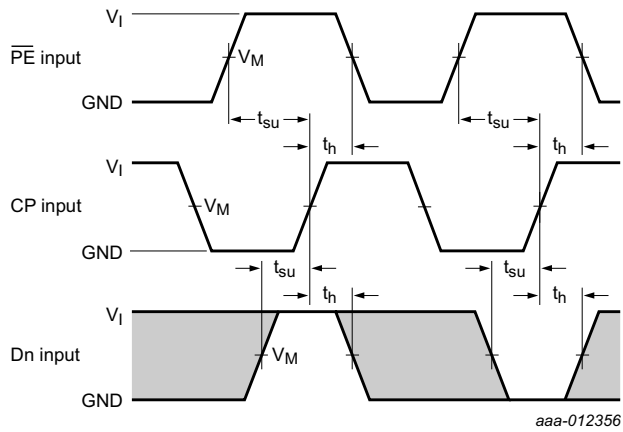

The shaded areas indicate when the input is permitted to change for predictable output performance.

Measurement points are given in [Table 8](#).

Fig 11. The data input (Dn) and parallel enable input (\overline{PE}) set-up and hold times

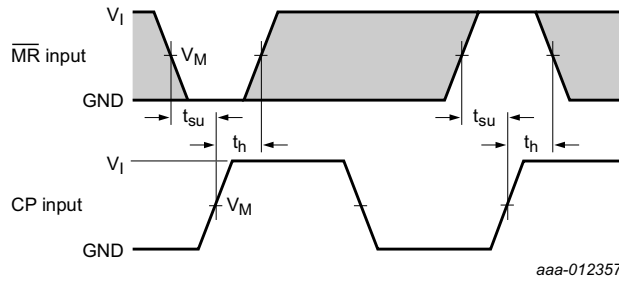

The shaded areas indicate when the input is permitted to change for predictable output performance. Measurement points are given in [Table 8](#).

Fig 12. The master reset (MR) set-up and hold times

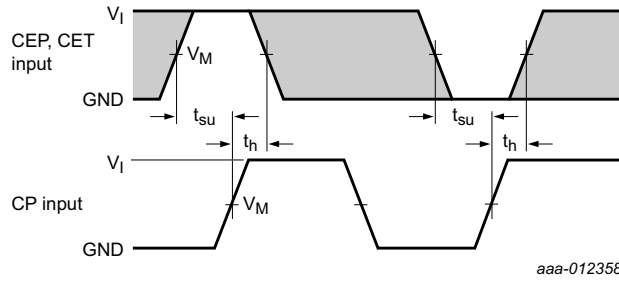

The shaded areas indicate when the input is permitted to change for predictable output performance. Measurement points are given in [Table 8](#).

Fig 13. The count enable input (CEP) and count enable carry input (CET) set-up and hold times

Table 8. Measurement points

Type	Input		Output
	V _M	V _I	V _M
74HC163	0.5 × V _{CC}	GND to V _{CC}	0.5 × V _{CC}
74HCT163	1.3 V	GND to 3 V	1.3 V

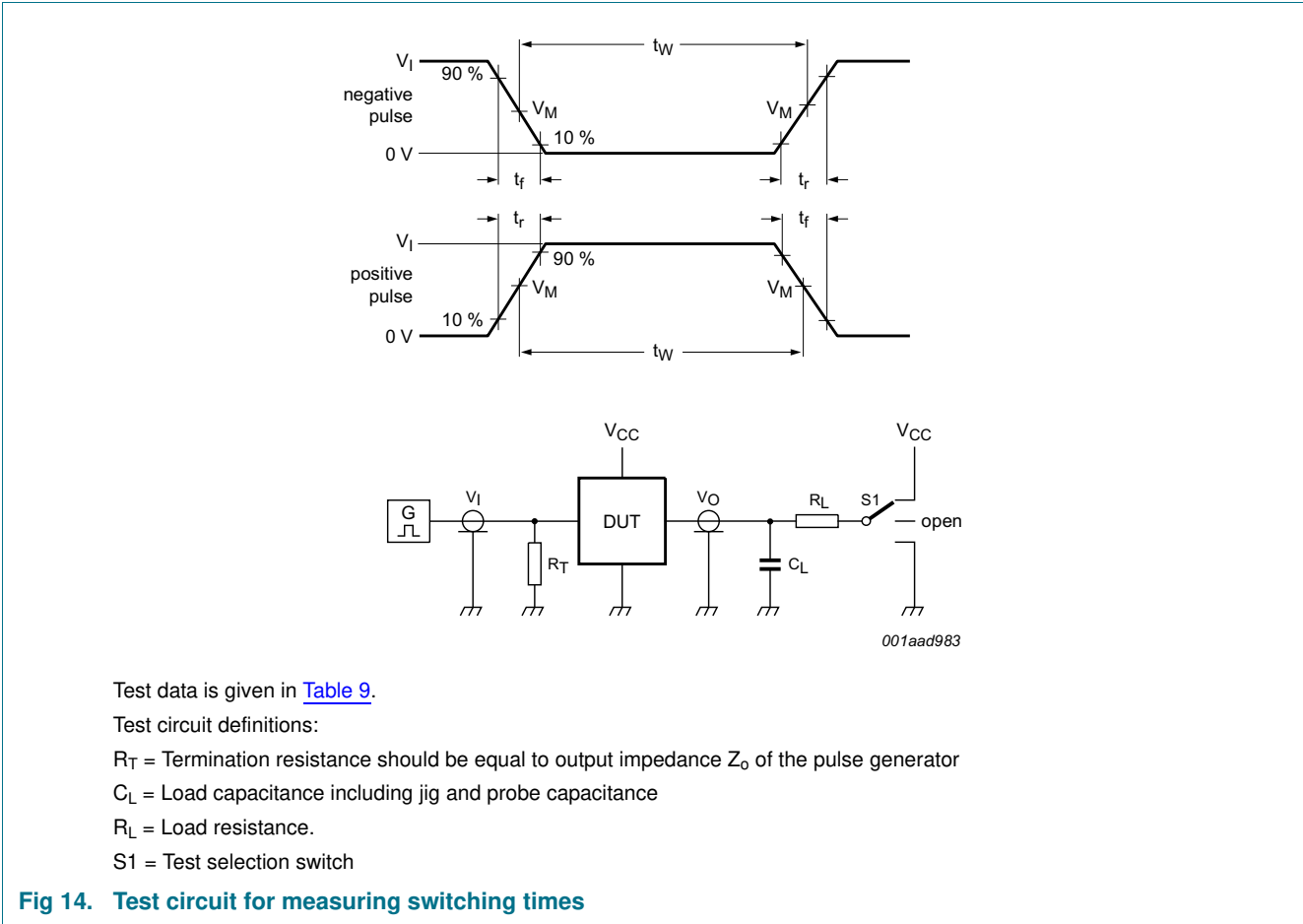

Table 9. Test data

Type	Input		Load		S1 position
	V_I	t_r, t_f	C_L	R_L	t_{PHL}, t_{PLH}
74HC163	V_{CC}	6 ns	15 pF, 50 pF	1 k Ω	open
74HCT163	3 V	6 ns	15 pF, 50 pF	1 k Ω	open

12. Application information

The 74HC163; 74HCT163 facilitate designing counters of any modulus with minimal external logic. The output is glitch-free due to the synchronous reset.

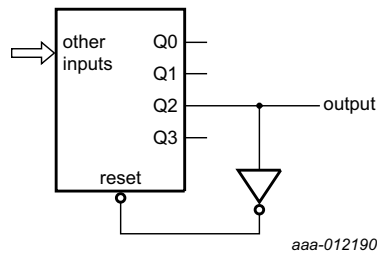

Fig 15. Modulo-5 counter

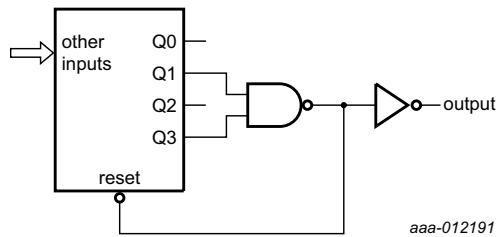

Fig 16. Modulo-11 counter

13. Package outline

SO16: plastic small outline package; 16 leads; body width 3.9 mm

SOT109-1

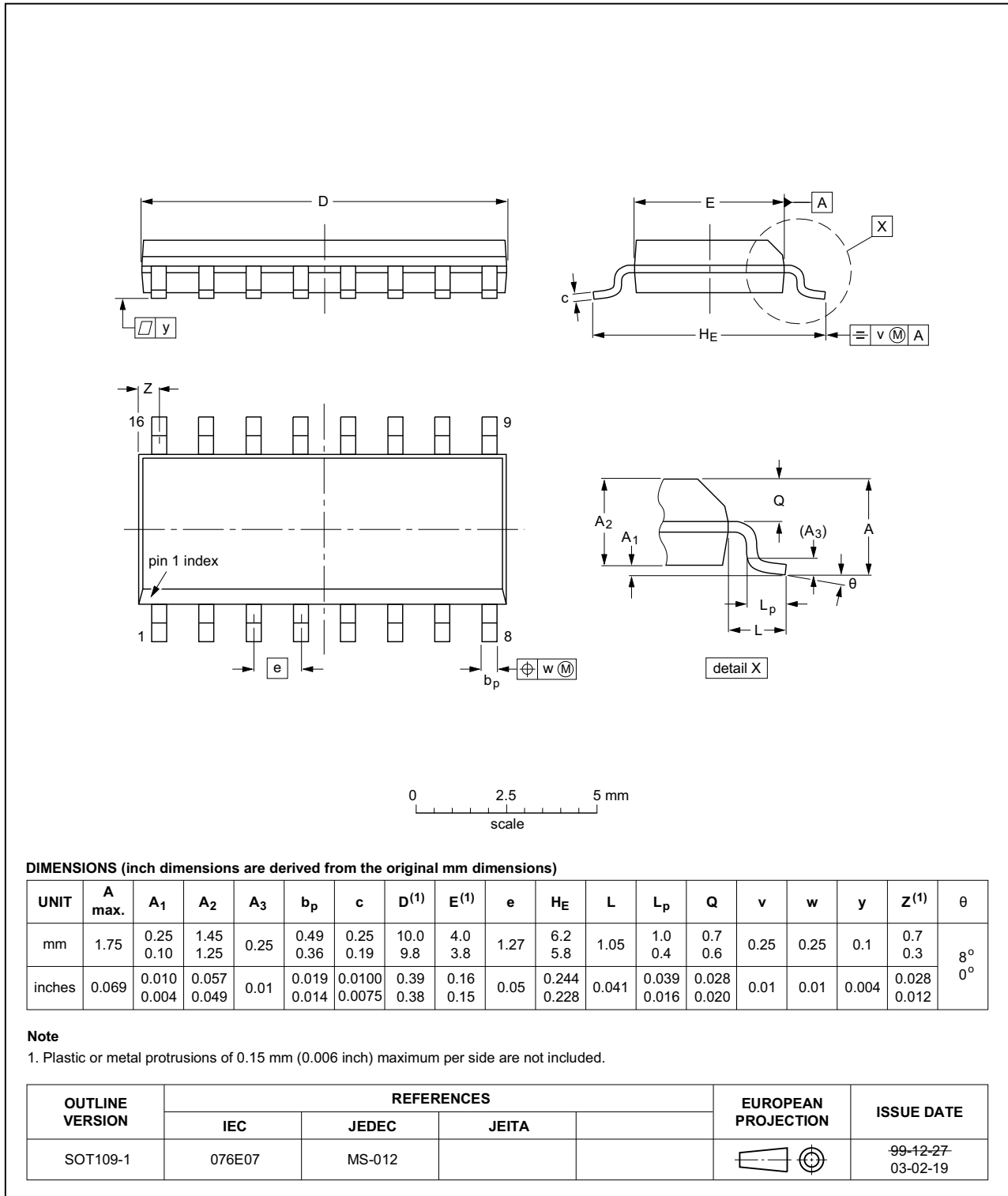

Fig 17. Package outline SOT109-1 (SO16)

SSOP16: plastic shrink small outline package; 16 leads; body width 5.3 mm

SOT338-1

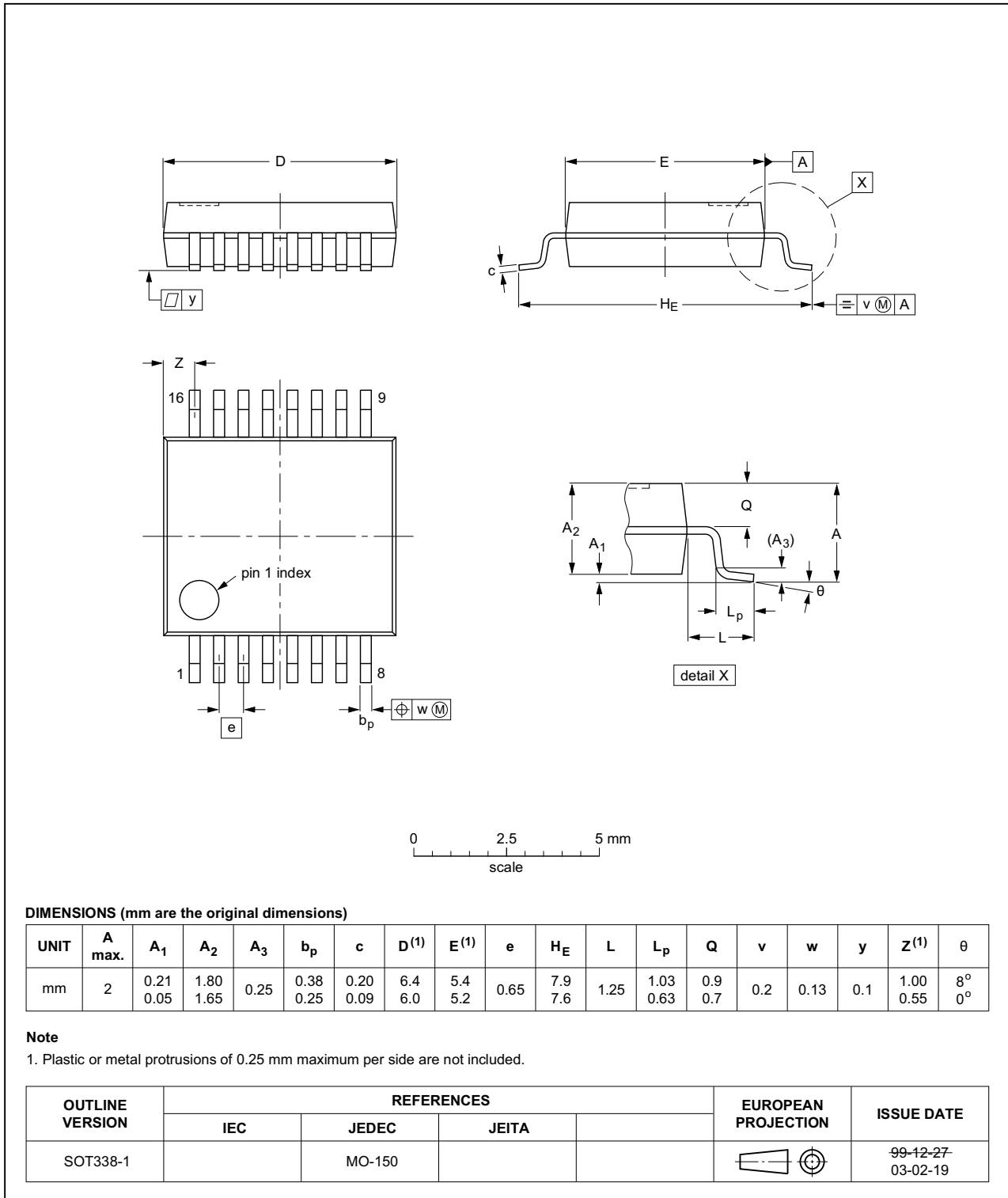

Fig 18. Package outline SOT338-1 (SSOP16)

TSSOP16: plastic thin shrink small outline package; 16 leads; body width 4.4 mm

SOT403-1

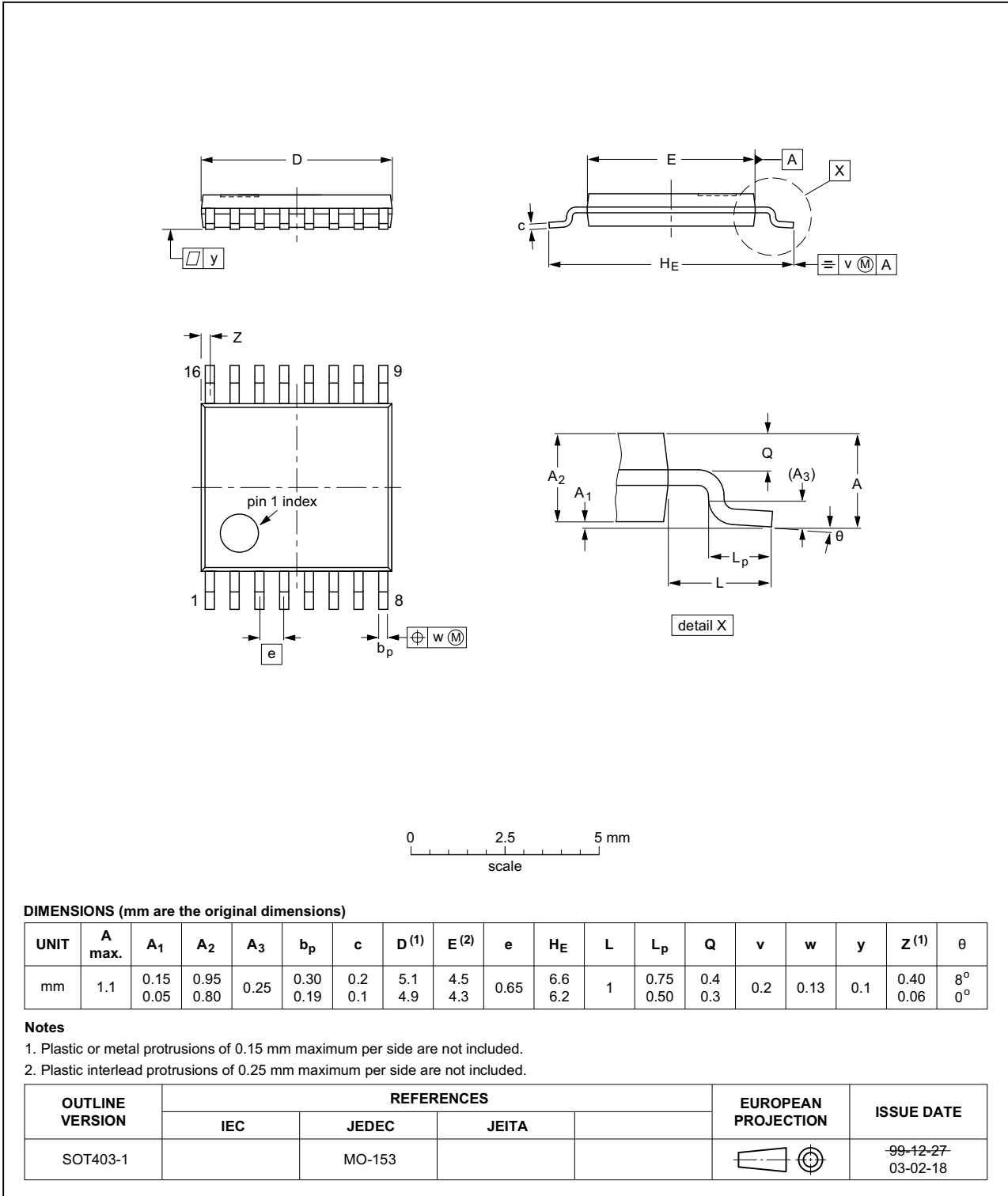

Fig 19. Package outline SOT403-1 (TSSOP16)

14. Abbreviations

Table 10. Abbreviations

Acronym	Description
CMOS	Complementary Metal-Oxide Semiconductor
DUT	Device Under Test
ESD	ElectroStatic Discharge
HBM	Human Body Model
MM	Machine Model
TTL	Transistor-Transistor Logic

15. Revision history

Table 11. Revision history

Document ID	Release date	Data sheet status	Change notice	Supersedes
74HC_HCT163 v.4	20151228	Product data sheet	-	74HC_HCT163 v.3
Modifications:	<ul style="list-style-type: none"> Type numbers 74HC163N and 74HCT163N (SOT38-4) removed. 			
74HC_HCT163 v.3	20140602	Product data sheet	-	74HC_HCT163_CNV v.2
Modifications:	<ul style="list-style-type: none"> The format of this data sheet has been redesigned to comply with the new identity guidelines of NXP Semiconductors. Legal texts have been adapted to the new company name where appropriate. 			
74HC_HCT163_CNV v.2	19930927	Product specification	-	-

16. Legal information

16.1 Data sheet status

Document status ^{[1][2]}	Product status ^[3]	Definition
Objective [short] data sheet	Development	This document contains data from the objective specification for product development.
Preliminary [short] data sheet	Qualification	This document contains data from the preliminary specification.
Product [short] data sheet	Production	This document contains the product specification.

[1] Please consult the most recently issued document before initiating or completing a design.

[2] The term 'short data sheet' is explained in section "Definitions".

[3] The product status of device(s) described in this document may have changed since this document was published and may differ in case of multiple devices. The latest product status information is available on the Internet at URL <http://www.nxp.com>.

16.2 Definitions

Draft — The document is a draft version only. The content is still under internal review and subject to formal approval, which may result in modifications or additions. NXP Semiconductors does not give any representations or warranties as to the accuracy or completeness of information included herein and shall have no liability for the consequences of use of such information.

Short data sheet — A short data sheet is an extract from a full data sheet with the same product type number(s) and title. A short data sheet is intended for quick reference only and should not be relied upon to contain detailed and full information. For detailed and full information see the relevant full data sheet, which is available on request via the local NXP Semiconductors sales office. In case of any inconsistency or conflict with the short data sheet, the full data sheet shall prevail.

Product specification — The information and data provided in a Product data sheet shall define the specification of the product as agreed between NXP Semiconductors and its customer, unless NXP Semiconductors and customer have explicitly agreed otherwise in writing. In no event however, shall an agreement be valid in which the NXP Semiconductors product is deemed to offer functions and qualities beyond those described in the Product data sheet.

16.3 Disclaimers

Limited warranty and liability — Information in this document is believed to be accurate and reliable. However, NXP Semiconductors does not give any representations or warranties, expressed or implied, as to the accuracy or completeness of such information and shall have no liability for the consequences of use of such information. NXP Semiconductors takes no responsibility for the content in this document if provided by an information source outside of NXP Semiconductors.

In no event shall NXP Semiconductors be liable for any indirect, incidental, punitive, special or consequential damages (including - without limitation - lost profits, lost savings, business interruption, costs related to the removal or replacement of any products or rework charges) whether or not such damages are based on tort (including negligence), warranty, breach of contract or any other legal theory.

Notwithstanding any damages that customer might incur for any reason whatsoever, NXP Semiconductors' aggregate and cumulative liability towards customer for the products described herein shall be limited in accordance with the *Terms and conditions of commercial sale* of NXP Semiconductors.

Right to make changes — NXP Semiconductors reserves the right to make changes to information published in this document, including without limitation specifications and product descriptions, at any time and without notice. This document supersedes and replaces all information supplied prior to the publication hereof.

Suitability for use — NXP Semiconductors products are not designed, authorized or warranted to be suitable for use in life support, life-critical or safety-critical systems or equipment, nor in applications where failure or malfunction of an NXP Semiconductors product can reasonably be expected to result in personal injury, death or severe property or environmental damage. NXP Semiconductors and its suppliers accept no liability for inclusion and/or use of NXP Semiconductors products in such equipment or applications and therefore such inclusion and/or use is at the customer's own risk.

Applications — Applications that are described herein for any of these products are for illustrative purposes only. NXP Semiconductors makes no representation or warranty that such applications will be suitable for the specified use without further testing or modification.

Customers are responsible for the design and operation of their applications and products using NXP Semiconductors products, and NXP Semiconductors accepts no liability for any assistance with applications or customer product design. It is customer's sole responsibility to determine whether the NXP Semiconductors product is suitable and fit for the customer's applications and products planned, as well as for the planned application and use of customer's third party customer(s). Customers should provide appropriate design and operating safeguards to minimize the risks associated with their applications and products.

NXP Semiconductors does not accept any liability related to any default, damage, costs or problem which is based on any weakness or default in the customer's applications or products, or the application or use by customer's third party customer(s). Customer is responsible for doing all necessary testing for the customer's applications and products using NXP Semiconductors products in order to avoid a default of the applications and the products or of the application or use by customer's third party customer(s). NXP does not accept any liability in this respect.

Limiting values — Stress above one or more limiting values (as defined in the Absolute Maximum Ratings System of IEC 60134) will cause permanent damage to the device. Limiting values are stress ratings only and (proper) operation of the device at these or any other conditions above those given in the Recommended operating conditions section (if present) or the Characteristics sections of this document is not warranted. Constant or repeated exposure to limiting values will permanently and irreversibly affect the quality and reliability of the device.

Terms and conditions of commercial sale — NXP Semiconductors products are sold subject to the general terms and conditions of commercial sale, as published at <http://www.nxp.com/profile/terms>, unless otherwise agreed in a valid written individual agreement. In case an individual agreement is concluded only the terms and conditions of the respective agreement shall apply. NXP Semiconductors hereby expressly objects to applying the customer's general terms and conditions with regard to the purchase of NXP Semiconductors products by customer.

No offer to sell or license — Nothing in this document may be interpreted or construed as an offer to sell products that is open for acceptance or the grant, conveyance or implication of any license under any copyrights, patents or other industrial or intellectual property rights.

Export control — This document as well as the item(s) described herein may be subject to export control regulations. Export might require a prior authorization from competent authorities.

Non-automotive qualified products — Unless this data sheet expressly states that this specific NXP Semiconductors product is automotive qualified, the product is not suitable for automotive use. It is neither qualified nor tested in accordance with automotive testing or application requirements. NXP Semiconductors accepts no liability for inclusion and/or use of non-automotive qualified products in automotive equipment or applications.

In the event that customer uses the product for design-in and use in automotive applications to automotive specifications and standards, customer (a) shall use the product without NXP Semiconductors' warranty of the product for such automotive applications, use and specifications, and (b) whenever customer uses the product for automotive applications beyond

NXP Semiconductors' specifications such use shall be solely at customer's own risk, and (c) customer fully indemnifies NXP Semiconductors for any liability, damages or failed product claims resulting from customer design and use of the product for automotive applications beyond NXP Semiconductors' standard warranty and NXP Semiconductors' product specifications.

Translations — A non-English (translated) version of a document is for reference only. The English version shall prevail in case of any discrepancy between the translated and English versions.

16.4 Trademarks

Notice: All referenced brands, product names, service names and trademarks are the property of their respective owners.

17. Contact information

For more information, please visit: <http://www.nxp.com>

For sales office addresses, please send an email to: salesaddresses@nxp.com

18. Contents

1	General description	1
2	Features and benefits	1
3	Ordering information	2
4	Functional diagram	2
5	Pinning information	4
5.1	Pinning	4
5.2	Pin description	4
6	Functional description	5
7	Limiting values	6
8	Recommended operating conditions	7
9	Static characteristics	7
10	Dynamic characteristics	9
11	Waveforms	12
12	Application information	16
13	Package outline	17
14	Abbreviations	20
15	Revision history	20
16	Legal information	21
16.1	Data sheet status	21
16.2	Definitions	21
16.3	Disclaimers	21
16.4	Trademarks	22
17	Contact information	22
18	Contents	23

Please be aware that important notices concerning this document and the product(s) described herein, have been included in section 'Legal information'.

© NXP Semiconductors N.V. 2015.

All rights reserved.

For more information, please visit: <http://www.nxp.com>

For sales office addresses, please send an email to: salesaddresses@nxp.com

Date of release: 28 December 2015

Document identifier: 74HC_HCT163