

4

3

2

1

THIS DRAWING IS UNPUBLISHED. RELEASED FOR PUBLICATION
 © COPYRIGHT - By - ALL RIGHTS RESERVED.

LOC	DIST	REVISIONS					
G	50	P	LTR	DESCRIPTION	DATE	DWN	APVD
		C		ECR-13-000998	11FEB2013	PK	HS

CRIMP LOCATION MARKS

SIGHT HOLE $\triangle 3$

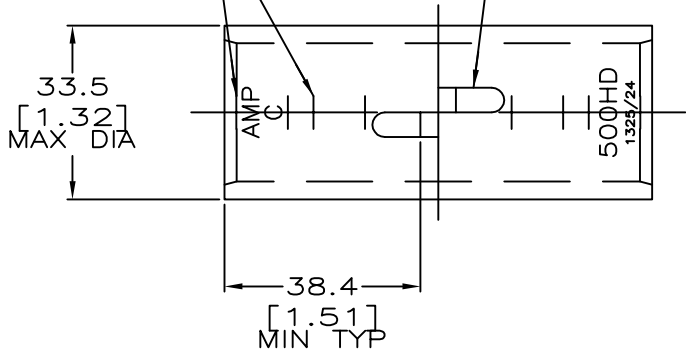

- 1 CIRCULAR MIL RANGE: 450-550 MCM
- 2 USE CRIMP DIES 46756-2 (600 MCM)

$\triangle 3$.045 MAX BURR ALLOWED INSIDE THE WIRE BARREL ID IN AREA OF SIGHT HOLE.

15° TYP

WIRE STOPS

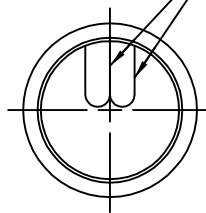

$\triangle 3$ 26.2 MIN DIA [1.03]

3.43 ± 0.08 [1.35 ± 0.003]

84.1 MAX [3.31]

696058-1
PART NUMBER

THIS DRAWING IS A CONTROLLED DOCUMENT.		DWN JR RUTH 28DEC98	 TE Connectivity SPLICE, BUTT, HEAVY DUTY, AMPPOWER, WIRE SIZE: 500 MCM		RESTRICTED TO			
DIMENSIONS: mm		CHK M BRENNEMAN 28DEC98			NAME		-	
TOLERANCES UNLESS OTHERWISE SPECIFIED:		APVD JL MECKLEY 28DEC98			PRODUCT SPEC		-	
0 PLC ± - 1 PLC ± - 2 PLC ± 0.20[.008] 3 PLC ± - 4 PLC ± - ANGLES ± 5°		APPLICATION SPEC			-			
MATERIAL COPPER	FINISH TIN PLATE	WEIGHT 242 grams	SIZE A3	CAGE CODE HS	DRAWING NO C=696058	SCALE 1:1		
CUSTOMER DRAWING			SHEET 1 OF 1	REV C				