

MATERIALS AND FINISHES:

BODY: BERYLLIUM COPPER
PLATED GOLD

CENTER CONTACT: BERYLLIUM COPPER
PLATED GOLD

INSULATOR: TEFLON

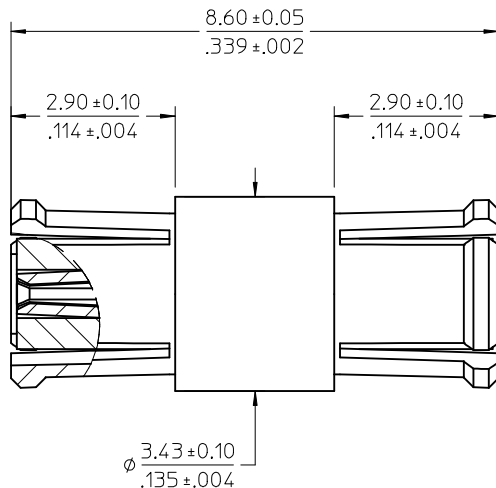
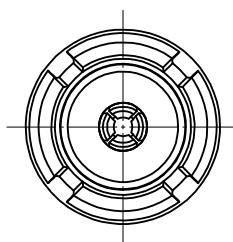
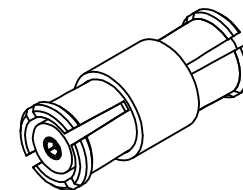

MODIFIED SMP JACK
INTERFACE
BOTH ENDS

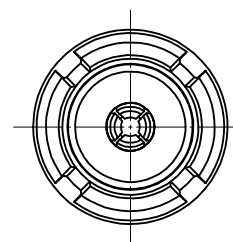

73406-0530	TRAY
PART NO.	PACKAGING

CHG/UPDATED VIEWS FOR BODY PER RF16-E053 EC NO: URF2016-0657 DRW:RYEH 2016/03/31 CHKD: APPR:YCHENG 2016/04/25	QUALITY SYMBOLS ∇=0 ∇=0 ∇=0	GENERAL TOLERANCES (UNLESS SPECIFIED)		DIMENSION STYLE	SCALE	DESIGN UNITS	THIRD ANGLE PROJECTION	
				MM/IN	15:1	METRIC		
				DRAWN BY	DATE	TITLE		
				RYEH	2015/10/07	MOD SMP JACK/JACK BULLET FEMALE TO FEMALE SMP-J/J		
				CHECKED BY	DATE			
				JOANNE LIAO	2015/10/07			
				APPROVED BY	DATE			
				YCHENG	2015/11/04	DOCUMENT NO.		
				MATERIAL NO.		SD-73406-053		
				SEE TABLE		SHEET NO.		
				SIZE		1 OF 2		
				THIS DRAWING CONTAINS INFORMATION THAT IS PROPRIETARY TO MOLEX INCORPORATED AND SHOULD NOT BE USED WITHOUT WRITTEN PERMISSION				



P/N: 73406-0530

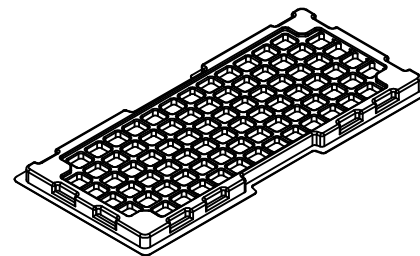

80 SETS PER TRAY
P/N: 89707-0190

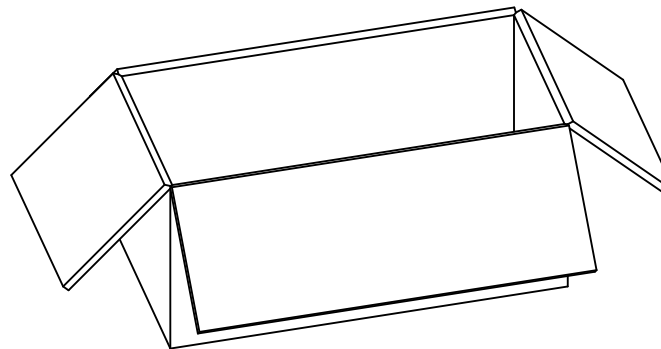

1600 SETS PER INNER
CARTON BOX
P/N: 96707-0001

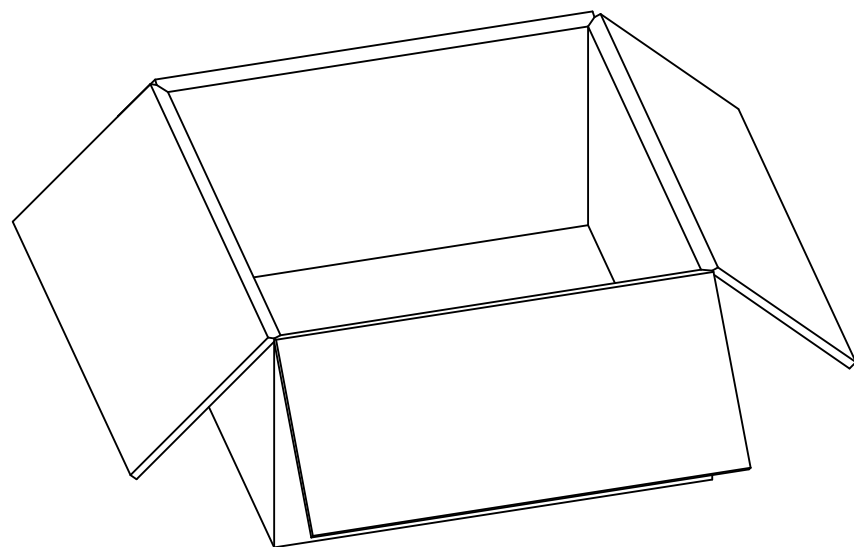

3200 SETS PER OUTER
CARTON BOX
P/N: 96708-0005



CHG:SEE SHEET 1
EC NO: URF2016-0657
DRAWN:RYEH 2016/03/31
CHKD:
APPR:YCHENG 2016/04/25

REV	DESCRIPTION	QUALITY SYMBOLS

GENERAL TOLERANCES (UNLESS SPECIFIED)

	mm	INCH
4 PLACES	± ---	± ---
3 PLACES	± ---	± ---
2 PLACES	± ---	± ---
1 PLACE	± ---	± ---
0 PLACE	± ---	± ---

ANGULAR ± 2 °

DRAFT WHERE APPLICABLE MUST REMAIN WITHIN DIMENSIONS

DIMENSION STYLE
MM/IN

DRAWN BY DATE
RYEH 2015/10/07

CHECKED BY DATE
JOANNE LIAO 2015/10/07

APPROVED BY DATE
YCHENG 2015/11/04

MATERIAL NO.
SEE TABLE

SCALE
2.5:1

DESIGN UNITS
METRIC

THIRD ANGLE PROJECTION

TITLE
MOD SMP JACK/JACK BULLET
FEMALE TO FEMALE
SMP-J/J

molex

DOCUMENT NO.
SD-73406-053

SHEET NO.
2 OF 2

THIS DRAWING CONTAINS INFORMATION THAT IS PROPRIETARY TO MOLEX INCORPORATED AND SHOULD NOT BE USED WITHOUT WRITTEN PERMISSION