

NPN Silicon RF Transistor

- For linear broadband amplifier application up to 500 MHz
- SAW filter driver in TV tuners
- Pb-free (RoHS compliant) package¹⁾
- Qualified according AEC Q101

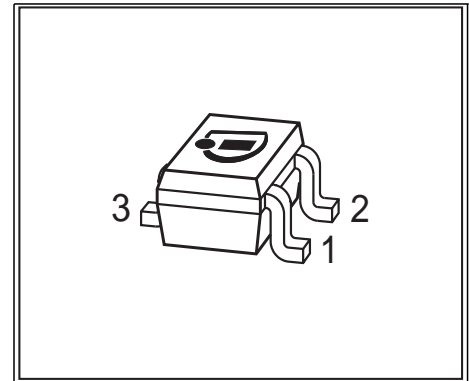

Type	Marking	Pin Configuration			Package
BF799W	LKs	1 = B	2 = E	3 = C	SOT323

Maximum Ratings

Parameter	Symbol	Value	Unit
Collector-emitter voltage	V_{CEO}	20	V
Collector-emitter voltage	V_{CES}	30	
Collector-base voltage	V_{CBO}	30	
Emitter-base voltage	V_{EBO}	3	
Collector current	I_C	35	mA
Base current	I_B	10	
Total power dissipation $T_S = 107\text{ °C}$	P_{tot}	280	mW
Junction temperature	T_j	150	°C
Storage temperature	T_{stg}	-65 ... 150	

Thermal Resistance

Junction - soldering point ²⁾	R_{thJS}	≤ 155	K/W
--	------------	------------	-----

¹Pb-containing package may be available upon special request

²For calculation of R_{thJA} please refer to Application Note Thermal Resistance

Electrical Characteristics at $T_A = 25\text{ °C}$, unless otherwise specified.

Parameter	Symbol	Values			Unit
		min.	typ.	max.	
DC characteristics					
Collector-emitter breakdown voltage $I_C = 1\text{ mA}, I_B = 0$	$V_{(BR)CEO}$	20	-	-	V
Collector-base breakdown voltage $I_C = 10\text{ }\mu\text{A}, I_E = 0$	$V_{(BR)CBO}$	30	-	-	
Base-emitter breakdown voltage $I_E = 10\text{ }\mu\text{A}, I_C = 0$	$V_{(BR)EBO}$	3	-	-	
Collector-base cutoff current $V_{CB} = 20\text{ V}, I_E = 0$	I_{CBO}	-	-	100	nA
DC current gain $I_C = 5\text{ mA}, V_{CE} = 10\text{ V}$ $I_C = 20\text{ mA}, V_{CE} = 10\text{ V}$	h_{FE}	35 40	95 100	- 250	-
Collector-emitter saturation voltage $I_C = 20\text{ mA}, I_B = 2\text{ mA}$	V_{CEsat}	-	0.1	0.3	V
Base-emitter saturation voltage $I_C = 20\text{ mA}, I_B = 2\text{ mA}$	V_{BEsat}	-	-	0.95	
AC characteristics					
Transition frequency $I_C = 5\text{ mA}, V_{CE} = 10\text{ V}, f = 100\text{ MHz}$ $I_C = 20\text{ mA}, V_{CE} = 8\text{ V}, f = 100\text{ MHz}$	f_T	- -	800 1100	- -	MHz
Output capacitance $V_{CB} = 10\text{ V}, I_E = 0\text{ mA}, f = 1\text{ MHz}$	C_{ob}	-	0.96	-	pF
Collector-base capacitance $V_{CB} = 10\text{ V}, f = 1\text{ MHz}$	C_{cb}	-	0.7	-	
Collector-emitter capacitance $V_{CE} = 10\text{ V}, f = 1\text{ MHz}$	C_{ce}	-	0.28	-	
Noise figure $I_C = 5\text{ mA}, V_{CE} = 10\text{ V}, f = 100\text{ MHz},$ $Z_S = 50\text{ }\Omega$	F	-	3	-	dB
Output conductance $I_C = 20\text{ mA}, V_{CE} = 10\text{ V}, f = 35\text{ MHz}$	g_{22e}	-	60	-	$\infty\text{ S}$

Total power dissipation $P_{tot} = f(T_S)$

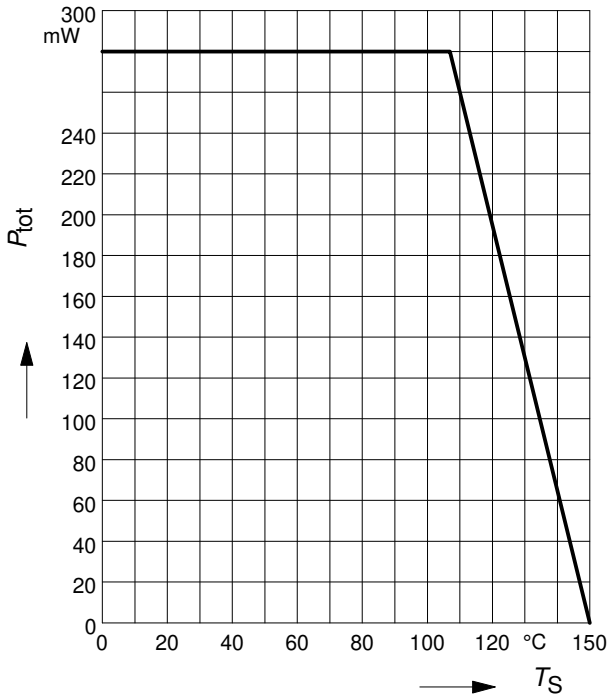

Permissible Pulse Load $R_{thJS} = f(t_p)$

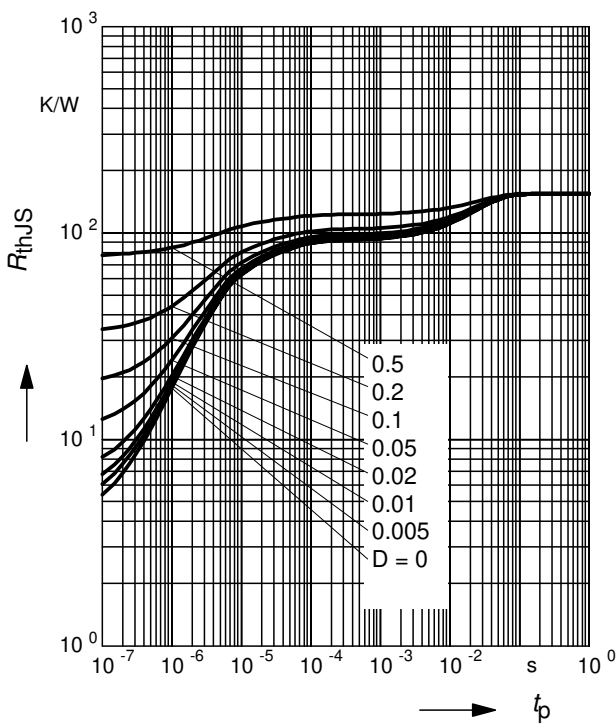

Permissible Pulse Load

$P_{totmax}/P_{totDC} = f(t_p)$

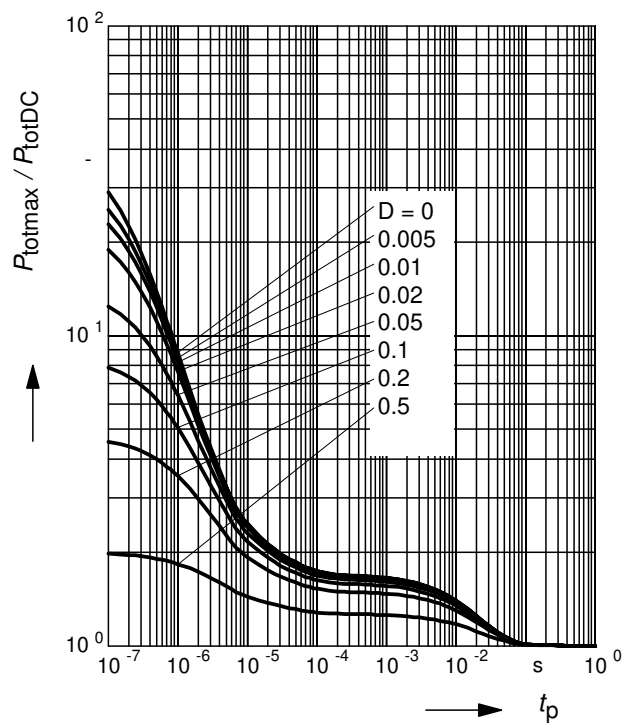

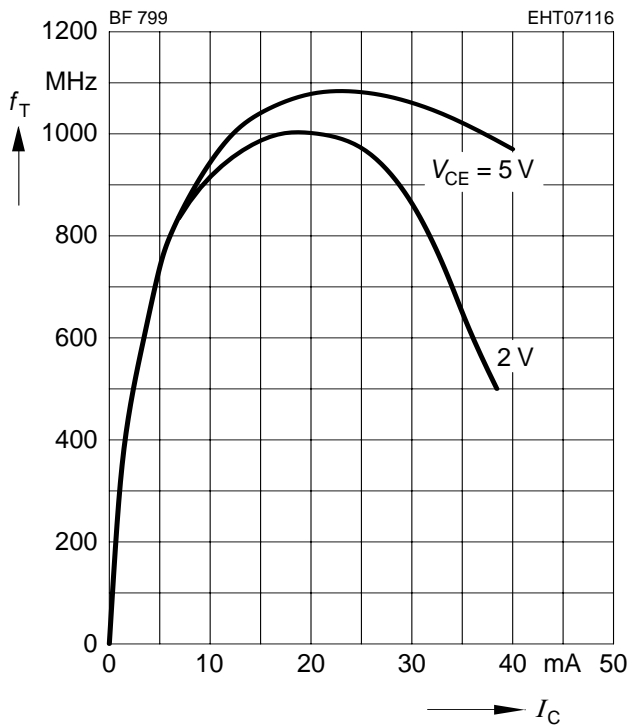
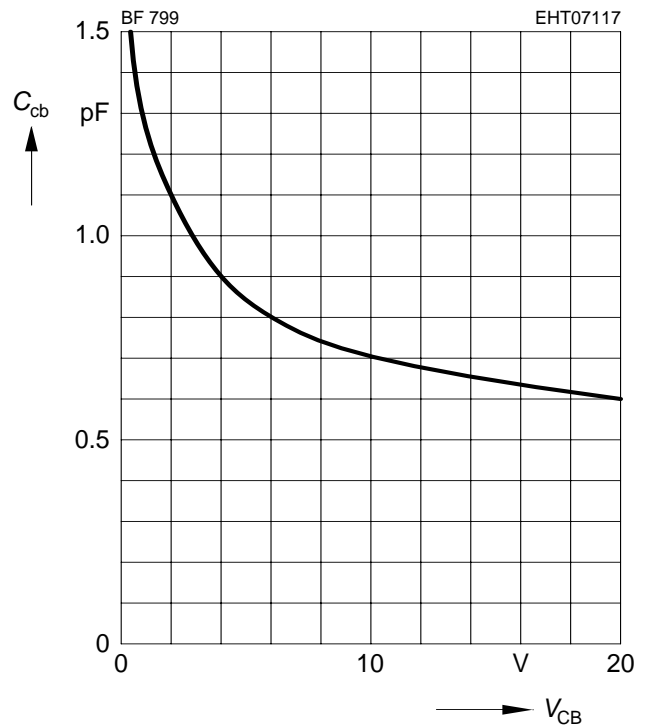
Transition frequency $f_T = f(I_C)$
 $f = 100\text{MHz}$

Collector-base capacitance $C_{cb} = f(V_{CB})$
 $f = 1\text{MHz}$

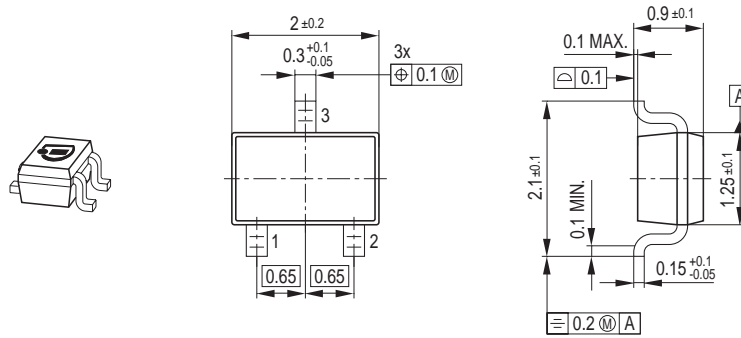
Package Outline

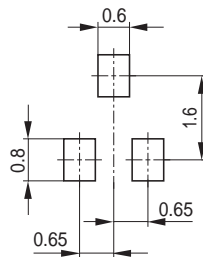

Foot Print



Marking Layout (Example)

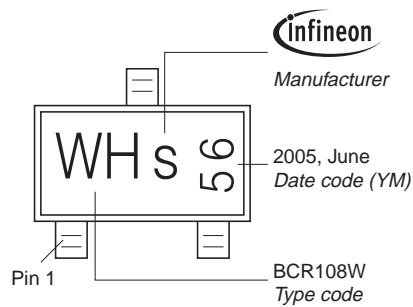

Standard Packing

Reel ø180 mm = 3.000 Pieces/Reel
 Reel ø330 mm = 10.000 Pieces/Reel

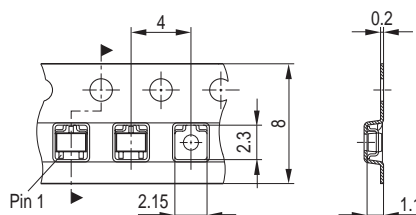

Published by
Infineon Technologies AG
81726 München, Germany
© Infineon Technologies AG 2006.
All Rights Reserved.

Attention please!

The information given in this data sheet shall in no event be regarded as a guarantee of conditions or characteristics ("Beschaffenheitsgarantie"). With respect to any examples or hints given herein, any typical values stated herein and/or any information regarding the application of the device, Infineon Technologies hereby disclaims any and all warranties and liabilities of any kind, including without limitation warranties of non-infringement of intellectual property rights of any third party.

Information

For further information on technology, delivery terms and conditions and prices please contact your nearest Infineon Technologies Office (www.infineon.com).

Warnings

Due to technical requirements components may contain dangerous substances. For information on the types in question please contact your nearest Infineon Technologies Office.

Infineon Technologies Components may only be used in life-support devices or systems with the express written approval of Infineon Technologies, if a failure of such components can reasonably be expected to cause the failure of that life-support device or system, or to affect the safety or effectiveness of that device or system.

Life support devices or systems are intended to be implanted in the human body, or to support and/or maintain and sustain and/or protect human life. If they fail, it is reasonable to assume that the health of the user or other persons may be endangered.