

Digital Process Controller Series

E5□K

Advanced Process Digital Controllers with Fuzzy Logic

- Field configurable outputs, options.
- 100 ms sampling (for analog input).
- Advanced PID, or fuzzy self-tuning.
- Conforms to UL, CSA and CE standards.
- Water-resistant front panel meets IP66/NEMA 4X.
- Remote set point with optional event input board.
- Set point ramp.
- Serial communications available.
- Front panel programming.
- Heat only or heat/cool control.
- Auxiliary outputs (SPST) standard; two for E5AK/E5EK, one for E5CK.
- 3-year warranty.



Ordering Information

Stock Note: Shaded models are normally stocked.

Note: Order Control Output Boards and Option Boards separately below.

Description	DIN size	Supply voltage	Model
Standard model	1/4 DIN (96 x 96 mm)	100 to 240 VAC	E5AK-AA2-500
Position-proportional model (See Note 3)		100 to 240 VAC	E5AK-PRR2-500
Standard model		24 VAC/VDC	E5AK-AA2-500 AC/DC24
Position-proportional model (See Note 3)		24 VAC/VDC	E5AK-PRR2-500 AC/DC24
Standard model	1/8 DIN (48 x 96 mm)	100 to 240 VAC	E5EK-AA2-500
Position-proportional model (See Note 3)		100 to 240 VAC	E5EK-PRR2-500
Standard model		24 VAC/VDC	E5EK-AA2-500 AC/DC24
Position-proportional model (See Note 3)		24 VAC/VDC	E5EK-PRR2-500 AC/DC24
Standard model	1/16 DIN (48 x 48 mm)	100 to 240 VAC	E5CK-AA1-500
Standard model		24 VAC/VDC	E5CK-AA1-500 AC/DC24
Non-standard model with built-in quick auto-tune button (See <i>Nomenclature</i> section for details)		100 to 240 VAC	E5CK-AA1-302

- Note: 1. When using the heater burnout alarm function with a standard model, the Linear Output Module cannot be used for the control outputs (heat). The Digital Controller provides transfer outputs at 4 to 20 mA for the PV and other values and control outputs at 4 to 20 mA for the current outputs.
2. E5EK-PRR2/E5AK-PRR2 controllers are supplied with dedicated relay output.
3. Position-proportional models are intended for motorized valves (not 4-20 mA modulating valves). These use two relays (“open” and “close”) which will turn a motor clockwise or counter-clockwise, thus opening or closing the valve.
4. Part numbers ending in -500 include a Finger Safe cover.

■ Optional Output Boards

Stock Note: Shaded models are normally stocked.

Description	Specifications	Compatible controller	Max. quantity	Model
Relay	SPST, 5 A, 250 VAC	E5AK/E5EK	2	E53-R
SSR (solid state relay)	1 A, 75 to 250 VAC	E5AK/E5EK	2	E53-S
Voltage pulse	NPN, 12 VDC	E5AK/E5EK	2	E53-Q
	NPN, 24 VDC	E5AK/E5EK	2	E53-Q3
	PNP, 24 VDC	E5AK/E5EK	2	E53-Q4
Linear current	4 to 20 mA	E5AK/E5EK	2	E53-C3
	0 to 20 mA	E5AK/E5EK	2	E53-C3D
Linear voltage	0 to 10 VDC	E5AK/E5EK	2	E53-V34
	0 to 5 VDC	E5AK/E5EK	2	E53-V35
Relay/Relay	SPST/SPST, 5 A, 250 VAC	E5CK	1	E53-R4R4
Relay/Pulse	SPST, 5 A/NPN, 24 VDC	E5CK	1	E53-Q4R4
	SPST, 5 A/PNP, 24 VDC	E5CK	1	E53-Q4HR4
Relay/Linear current	SPST, 5 A/4 to 20 mA	E5CK	1	E53-C4R4
	SPST, 5 A/0 to 20 mA	E5CK	1	E53-C4DR4
Relay/Linear voltage	SPST, 5 A/0 to 10 VDC	E5CK	1	E53-V44R4
Pulse/Pulse	NPN/NPN, 24 VDC	E5CK	1	E53-Q4Q4
	PNP/PNP, 24 VDC	E5CK	1	E53-Q4HQ4H
Computer communications	RS-232C	E5AK/E5EK	3/1	E53-AK01
	RS-232C	E5CK	1	E53-CK01
	RS-422	E5AK/E5EK	3/1	E53-AK02
	RS-485	E5AK/E5EK	3/1	E53-AK03
		E5CK	1	E53-CK03
Event input	For remote set point	E5AK/E5EK	3/1	E53-AKB
	For remote set point	E5CK	1	E53-CKB
Transfer output	4 to 20 mA	E5AK/E5EK	3/1	E53-AKF
	4 to 20 mA	E5CK	1	E53-CKF

Note: If the control period is less than 5 seconds, use an SSR (solid state relay) or pulse voltage output.

■ Accessories (Order Separately)

Stock Note: Shaded models are normally stocked.

Description	Specifications	Compatible controller	Max. quantity	Model
Current transformer; order only if using heater burnout alarm function	50 A load, 5.8 mm hole dia.	E5AK/E5EK	1	E54-CT1
	120 A load, 12 mm hole dia.	E5AK/E5EK	1	E54-CT3
Terminal cover (supplied with Standard models)	Provides finger protection from terminals (VDE0106 part 100)	E5AK	1	E53-COV0809
		E5CK	1	E53-COV07
		E5EK	1	E53-COV08
Software	For setup and monitoring; requires optional computer communications board	All	1	Thermo Tools (See Note)

Note: Contact Omron for current version information.

Input Types (selectable with input jumper connector)

Thermocouple

Input (field selectable) (See Notes)		K1	K2	J1	J2	T	E	L1	L2	U	N	R	S	B	W	PLII
Range	°C	-200 to 1,300	0.0 to 500.0	-100 to 850	0.0 to 400.0	-199.9 to 400.0	0 to 600	-100 to 850	0.0 to 400.0	-199.9 to 400.0	-200 to 1,300	0 to 1,700	0 to 1,700	100 to 1,800	0 to 2,300	0 to 1,300
	°F	-300 to 2,300	0.0 to 900.0	-100 to 1,500	0.0 to 750.0	-199.9 to 700.0	0 to 1,100	-100 to 1,500	0.0 to 750.0	-199.9 to 700.0	-300 to 2,300	0 to 3,000	0 to 3,000	300 to 3,200	0 to 4,100	0 to 2,300

- Note: 1. Setting number is factory-set to 2 (K1).
 2. Thermocouple W is W/Re5-26 (tungsten rhenium 5, tungsten rhenium 26).

Platinum Resistance Thermometer (RTD's)

Input (field selectable)		JPt100	Pt100
Range	°C	-199.9 to 650.0	-199.9 to 650.0
	°F	-199.9 to 999.9	-199.9 to 999.9

Current/Voltage

Input (field selectable)	Current input		Voltage input		
		4 to 20 mA	0 to 20 mA	1 to 5 V	0 to 5 V

Note: When a current/voltage input is selected, the decimal point is fully adjustable.

Specifications

■ Ratings

Model		E5□K Standard	E5□K 24V AC/DC	
Supply voltage		100–240 VAC, 50/60 Hz		
Operating voltage range		85% to 110% of rated supply voltage		
Power consumption	E5AK	16 VA	9 VA, 6 W	
	E5EK	15 VA	9 VA, 6 W	
	E5CK	10 VA (at 100 VAC) 14 VA (at 240 VAC)	6 VA, 3.5 W	
Input	Thermocouple	K, J, T, E, L, U, N, R, S, B, W, PLII		
	Platinum resistance thermometer (RTD)	JPt100, Pt100		
	Current input	4 to 20 mA, 0 to 20 mA		
	Voltage input	1 to 5 V, 0 to 5 V, 0 to 10 V		
Mean Time Between Failure		15.4 years (135,000 hours)		
Control output (See Note 1)	Relay	SPST, 3 A at 250 VAC (resistive load) Mechanical life expectancy: 10,000,000 operations min. Electrical life expectancy: 100,000 operations min.		
	Voltage (pulse)	NPN	20 mA at 12/24 VDC (with short-circuit protection)	
		PNP	20 mA at 24 VDC (with short-circuit protection)	
	Linear voltage	0 to 10 VDC	Permissible load impedance: 1 kΩ min. Resolution: Approximately 2600 steps	
	Linear current	4 to 20 mA	Permissible load impedance: 500 Ω max. Resolution: Approximately 2600 steps	
0 to 20 mA		Permissible load impedance: 500 Ω max. Resolution: Approximately 2600 steps		
Auxiliary output	SPST-NO	E5AK	3 A at 250 VAC (resistive load)	
		E5EK	3 A at 250 VAC (resistive load)	
		E5CK	1A at 250 VAC (resistive load)	
Control method (See Note 2)		ON/OFF, Advanced PID Control (with auto-tuning) or Self-tuning		
Setting method		Digital setting using front panel keys or communications features		
Indication method - 7-seg. digital display and LEDs		E5AK: PV = 15 mm, SP = 10.5 mm E5EK: PV = 14 mm, SP = 9.5 mm E5CK: PV = 12 mm, SP = 8 mm		
Potentiometer for valve positioning (for E5AK-PRR and E5EK-PRR only)		100 Ω to 2.5 kΩ		
Event input	Contact input	ON	1 kΩ max.	
		OFF	100 kΩ min.	
	No-contact input	ON	residual voltage: 1.5 V max.	
		OFF	leakage current: 0.1 mA max.	
Transmission output		4 to 20 mA, permissible load impedance: 600 Ω max., resolution: Approximately 2600 steps		
Remote SP input (for E5AK and E5EK only)	Current input	4 to 20 mA (Input impedance: 150 Ω)		
Current Transformer input (for E5AK and E5EK only)		Connect only an Omron Current Transformer (E54-CT1 or E54-CT3)		
Other functions	Standard	Manual output, heating/cooling control, SP limiter, loop burnout alarm, SP ramp, MV limiter, MV change rate limiter, input digital filter, input shift, run/stop, protect functions		
	Option	Multiple SP, run/stop selection, transfer output functions, auto/manual Communications (RS-232C, RS-422, or RS-485), Loop Break Alarm, and Transfer Output.		
Standards	UL	File No.: E68481		
	CSA	File No.: LR59623		
	CE	File No.: EN50081-2; EN50082-2; IEC 1010-1		

Note: 1. All control outputs are insulated from the input circuit.
2. Fuzzy self-tuning is available only when using the Digital Controller in standard control operation with temperature input.

■ Characteristics

Indication accuracy (See Note)		Thermocouple: ±0.3% of indication value or ±1°C, whichever is greater, ±1 digit max. Platinum resistance thermometer: ±0.2% of indication value or ±0.8°C, whichever is greater, ±1 digit max. Analog input: ±0.2% (of indication value) ±1 digit max.
Hysteresis		0.01% to 99.99% FS (in units of 0.01% FS)
Proportional band (P)		0.1% to 999.9% FS (in units of 0.1% FS)
Integral (reset) time (I)		0 to 3,999 s (in units of 1 s)
Derivative (rate) time (D)		0 to 3,999 s (in units of 1 s)
Control period		1 to 99 s (in units of 1 s)
Manual reset value		0.0% to 100.0% (in units of 0.1%)
Alarm setting range		-1,999 to 9,999 or -199.9 or 999.9 (decimal point position dependent on input type)
Sampling period	Temperature input	250 ms scan rate
	Analog input	100 ms scan rate
Insulation resistance		200 MΩ min. (at 500 VDC)
Dielectric strength		2,000 VAC, 50/60 Hz for 1 min between terminals of different polarities
Vibration resistance	Malfunction	10 to 55 Hz, 10 m/s ² (approx. 1G) for 10 min each in X, Y, and Z directions
	Mechanical	10 to 55 Hz, 20 m/s ² (approx. 2G) for 2 hrs each in X, Y, and Z directions
Shock resistance	Malfunction	200 m/s ² min. (approx. 20G), 3 times each in 6 directions (100 m/s ² (approx. 10G) applied to the relay)
	Mechanical	300 m/s ² min. (approx. 30G), 3 times each in 6 directions
Ambient temperature	Operating	-10°C to 55°C (14°F to 131°F) with no icing; with 3-year warranty period: -10°C to 50°C (14°F to 122°F)
	Storage	-25°C to 65°C (-13°F to 149°F) with no icing
Ambient humidity	Operating	35% to 85% RH
Enclosure ratings	Front panel	NEMA 4X for indoor use (equivalent to IP66)
	Rear case	IEC standard IP20
	Terminals	IEC standard IP00
Memory protection		Non-volatile memory (number of writings: 100,000 operations)
Weight	E5AK	Approx. 450 g
	E5EK	Approx. 320 g
	Mounting bracket	Approx. 65 g
	E5CK	Approx. 170 g
	Adapter	Approx. 10 g
EMC		Emission Enclosure: EN55011 Group 1 class A Emission AC Mains: EN55011 Group 1 class A Immunity ESD: EN61000-4-2: 4 kV contact discharge (level 2) 8 kV air discharge (level 3) Immunity RF-interference: ENV50140: 10 V/m (amplitude modulated, 80 MHz to 1 GHz) (level 3) 10 V/m (pulse modulated, 900 MHz) Immunity Conducted Disturbance: ENV50141: 10 V (0.15 to 80 MHz) (level 3) Immunity Burst: EN61000-4-4: 2 kV power-line (level 3) 2 kV I/O signal-line (level 4)
Standards - Approvals		UL1092, CSA22.2 No. 14, CSA22.2 No. 1010-1 Conforms to EN50081-2, EN50082-2, EN61010-1 (IEC1010-1) Conforms to VDE0106/part 100 (Finger Protection)

Note: Indication Accuracy -

Of the K1, T, and N thermocouples at a temperature of -100°C or less: ±2°C ±1 digit maximum.

Of the U, L1, and L2 thermocouples at any temperature: ±2°C ±1 digit maximum.

Of the B thermocouple at a temperature of 400°C or less: unrestricted.

Of the R and S thermocouples at a temperature of 200°C or less: ±3°C ±1 digit maximum.

Of the W thermocouple at any temperature: ±0.3% of the indicated value or ±3°C, (whichever is greater) ±1 digit maximum.

Of the PLII thermocouple at any temperature: ±0.3% or ±2°C, whichever is greater ±1 digit maximum.

■ Option Board Ratings and Characteristics

Event inputs		Contact input: ON: 1 k Ω max., OFF: 100 k Ω min. No-contact input: ON: residual voltage 1.5 V max., OFF: leakage current 0.1 mA max.
Communications	Interface	RS-232C and RS-485; RS-422 for E5AK and E5EK only
	Transmission method	Half-duplex
	Synchronization method	Start-stop synchronization (asynchronous method)
	Baud rate	1.2/2.4/4.8/9.6/19.2 kbps
Transfer output		4 to 20 mA: Permissible load impedance: E5AK and E5EK = 600 Ω max. E5CK = 500 Ω max. Resolution: E5AK and E5EK = approx. 2,600 steps E5CK = approx. 2,600 steps RS-232C Peer-to-peer only; maximum cable length = 15 m (49.2 feet) RS-422 and RS-485 32 controller maximum to host computer; maximum cable length = 500 m (1640 feet)

■ Current Transformer Ratings

Part number	E54-CT1	E54-CT3
Max. continuous heater current	50 amps	120 amps (See Note 1)
Dielectric strength	1,000 VAC (for 1 min)	
Vibration resistance	50 Hz, 98 m/s ² (10G)	
Weight	Approx. 11.5 g	Approx. 50 g
Accessories	--	Armature: 2; Plug: 2

Note: 1. Use within the max. heater current rating of controller table shown below.

■ Heater Burnout Alarm

Max. heater current	Single-phase 50 A AC
Heater current value display accuracy	$\pm 5\%$ FS ± 1 digit max.
Heater burnout alarm setting range	0.1 to 49.9 A (in units of 0.1 A) (See Note 1)
Min. detection ON time	190 ms (See Note 2)

Note: 1. The heater burnout alarm is always OFF if the alarm is set to 0.0 A and always ON if the alarm is set to 50.0 A.

2. No heater burnout detection or heater current value measurement is possible if the control output (heat) is ON for less than 190 ms.

Nomenclature

E5AK

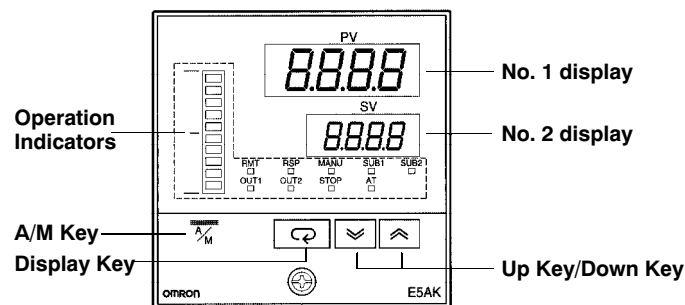

E5EK

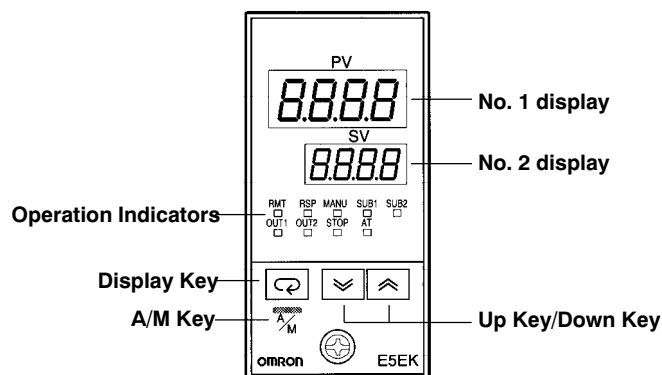

E5CK

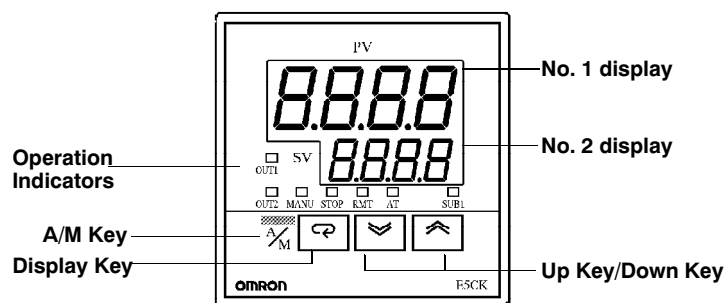

E5CK-302

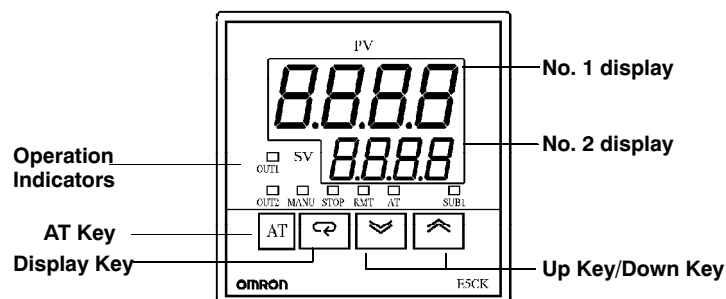

Operation Indicators

- **OUT1**
Lit when control output 1 turns ON.
- **OUT2**
Lit when control output 2 turns ON.
- **SUB1**
Lit when the output function assigned to auxiliary output 1 turns ON.
- **SUB2** (for E5AK and E5EK only)
Lit when the output function assigned to auxiliary output 2 turns ON.
- **MANU**
Lit when the manual operation mode is being used.
- **STOP**
Lit when control operation has been stopped.
- **RMT**
Lit during remote communications operation.
- **AT**
Flashes during auto-tuning. Auto-tuning is completed when this LED stops flashing.
- **RSP** (for E5AK and E5EK only)
Lit during remote SP operation.
- **Bar Graph** (for E5AK only)
On a standard model (E5AK-AA2), this bar graph indicates the manipulated variable (heat) in 10% increments per single segment. On a position-proportional model (E5AK-PRR2), this bar graph indicates the valve opening in 10% increments per single segment.

No. 1 Display

Displays the process value or parameter symbols.

No. 2 Display

Displays the set point, set point during SP ramp, manipulated variable, or parameter settings.

A/M Key

Press to select the auto operation or manual operation.

Up Key/Down Key

Press to increase or decrease the value on the No.2 display.

Display Key

Press quickly (for less than 1 s) to shift the display to the next parameter. When this key is pressed for 1 s or more, the menu screen will be displayed in any case.

- **AT**
Press key for automatic tuning.
- **A/M**
This feature is located in level one. (Replaced AT feature in level one).

Operation

Operating Parameters

Mode Selection

Press the Display Key for 1 sec. min. to switch to modes other than the manual or protect mode.

The figure below (Menu Display) shows all modes in the order that they are displayed. Some parameters are not displayed, depending on the protect mode setting and the option boards used.

Menu Display

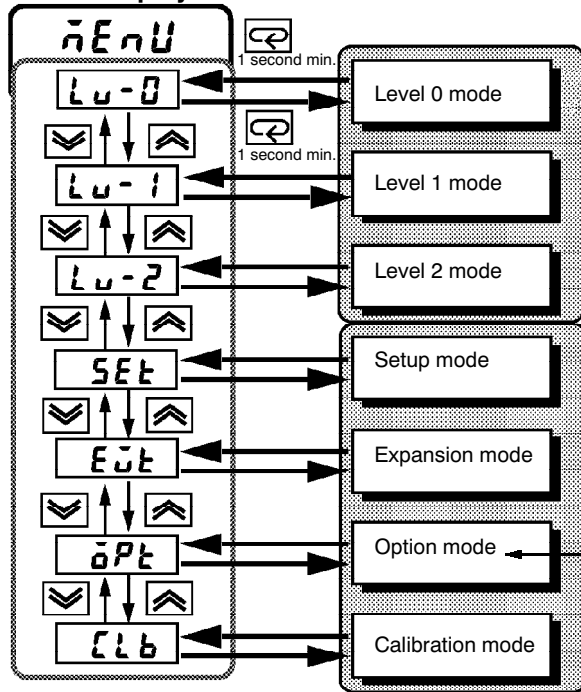

To Access *Protect Mode*

Press and hold the A/M Key and the Display Key for more than 1 second.

To Return to the Main PV/SP Display from the *Protect Mode*

Press and hold the A/M Key and the Display Key for more than 1 second.

To Access *Manual Mode*

Press and hold the A/M Key for more than 1 second.

To switch parameters **within** a mode, use the Display Key. Press the display key for less than one second to move between parameters.

Note: 1. In Level 0 mode, Level 1 mode, and Level 2 mode: The controller will maintain control of the process.

2. In Setup mode, Expansion mode, Option mode, and Calibration mode: Control of the process is not maintained. The outputs are inactive.

3. Option Mode will be accessible only when an option board is installed in the controller.

Parameters And Menus - For Setting The Controller

- Protect Mode** **Limits use of the menu and A/M Keys.**
The protect function prevents unwanted modification of parameters and can also be used to prevent switching between the auto and manual operation.
- Manual Mode** **Sets the controller to manual operation mode.**
You can only manually adjust the manipulated variable (MV) in this mode.
- Level 0 Mode** **For normal operation.**
Change: the set point during operation, and start or stop Controller operation; and, (only in this mode) monitor the process value, ramp SP, and manipulated variable.
- Level 1 Mode** **For adjusting primary control parameters.**
Execute: AT (auto-tuning); set alarm values; set the control period; and, set PID parameters.
- Level 2 Mode** **For adjusting secondary control parameters.**
Set parameters for: limiting the manipulated variable and set point; switch between the remote and local modes; set the loop break alarm (LBA), alarm hysteresis, and the digital filter value of inputs.
- Setup Mode** **For setting the basic specifications.**
Set parameters for: input type, scaling, output assignments and direct/reverse operation.
- Expansion Mode** **For setting expanded functions.**
Set: ST (self-tuning), SP setting limiter. Select: advanced PID or ON/OFF control. Specify the standby sequence resetting method. Initialize parameters; and, set the time for automatic return to the monitoring display.
- Option Mode** **For setting option functions.**
Set: the communications conditions; transfer: output and event input parameters to match the type of Option Board installed in the Controller. *This mode will be accessible only when an option board is installed in the controller.*
- Calibration Mode** **For calibrating inputs and transfer output.**
Calibrate the selected input type. *Transfer output can be calibrated only when the Communications Unit (E53-CKF) has been installed in the Controller.*

Dimensions

Unit: mm (inch)

E5AK

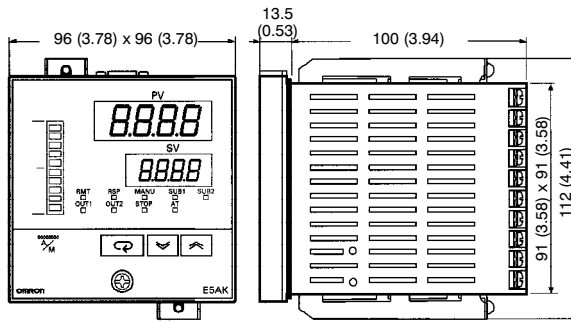
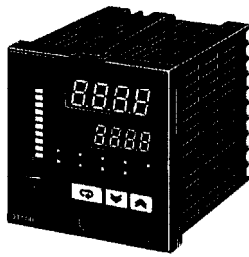

Panel Cutouts

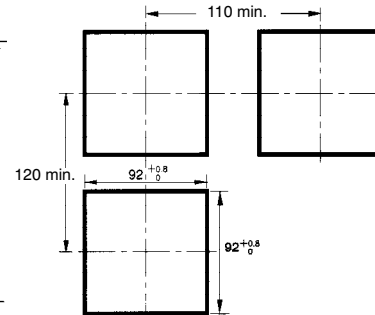

- Note: 1. Recommended panel thickness is 1 to 8 mm.
 2. Maintain the specified vertical and horizontal mounting space between each Unit. Units must not be closely mounted vertically or horizontally.

E5EK

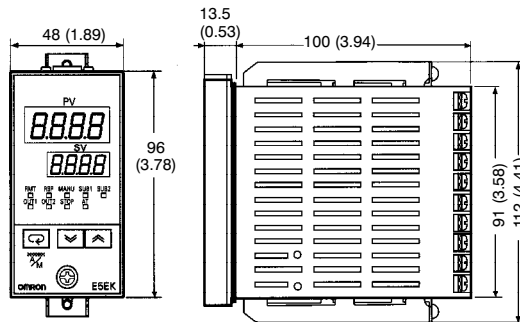
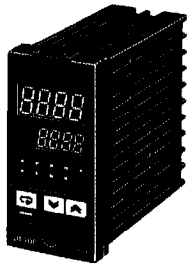

Panel Cutouts

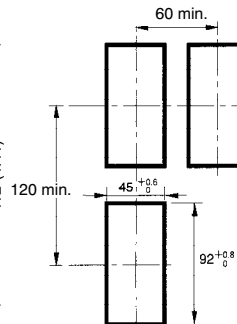

- Note: 1. Recommended panel thickness is 1 to 8 mm.
 2. Maintain the specified vertical and horizontal mounting space between each Unit. Units must not be closely mounted vertically or horizontally.

E5CK

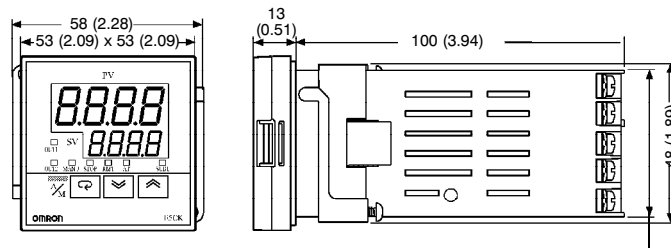

Panel Cutouts

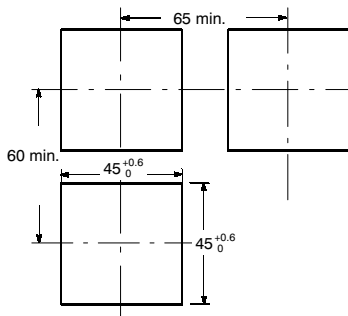

- Note: 1. Recommended panel thickness is 1 to 5 mm.
 2. Maintain the specified vertical and horizontal mounting space between each Unit. Units must not be closely mounted, either vertically or horizontally.

44.8 (1.76) x 44.8 (1.76)

■ E5CK-302

The E5CK-302 model has the same dimension and cutouts as the E5CK.

■ Accessories (Order Separately)

Terminal Cover for E5AK

E53-COV0809

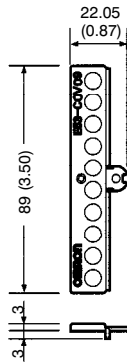
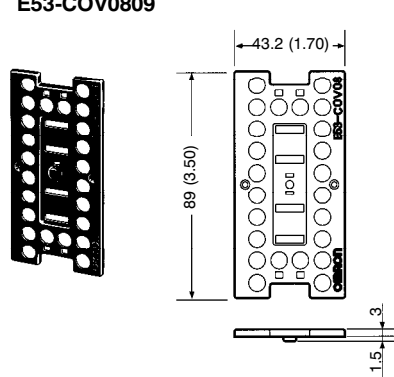

Terminal Cover for E5EK

E53-COV08

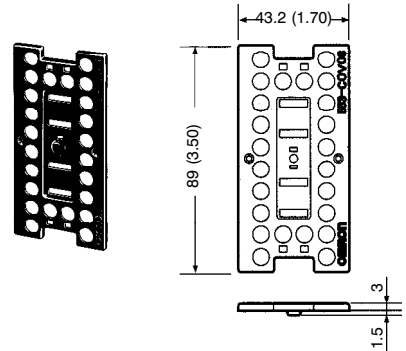

Terminal Cover for E5CK

E53-COV07

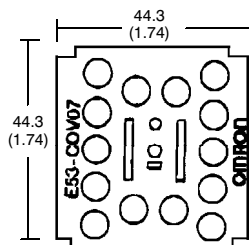

Current Transformer (E5AK and E5EK only for Heater Burnout Alarm)

E54-CT1

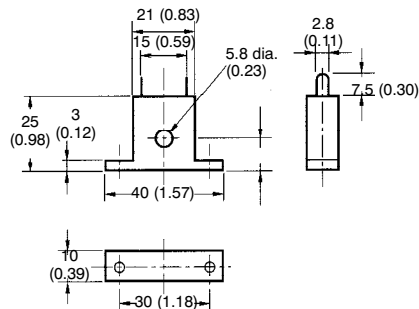
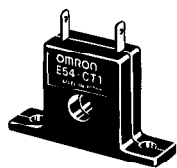

E54-CT3

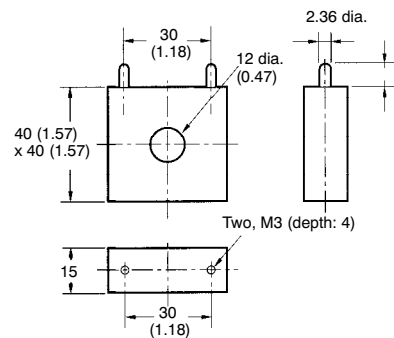
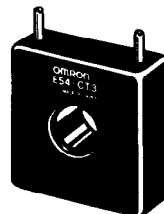

Installation

Remove Controller From Rear Housing

E5AK and E5EK

To pull out the internal mechanism from the housing, use a Phillips screwdriver matching the screw on the lower part of the front panel.

1. Turn the screw counterclockwise while pressing the hook on the upper part of the front panel.
2. Carefully pull out the internal mechanism while holding the left and right sides of the front panel.

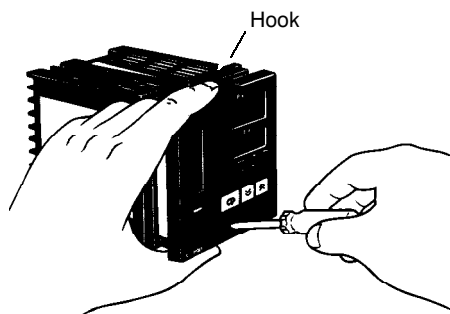

E5CK

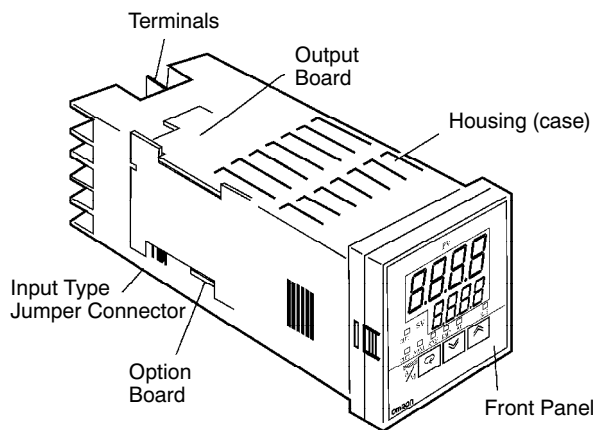

First, while pressing the hooks on the left and right sides of the front panel, pull the internal mechanism from the housing.

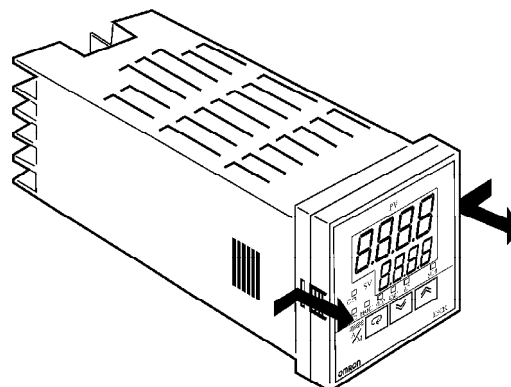

Settings

Note: Always turn off the power supply to the Digital Controller before changing any switch settings.

On a standard model, set up the Output Modules for control outputs 1 and 2 before mounting the Controller.

On a position-proportional model, the Relay Output Module is already set. Do not change that set-up parameter. Do not replace with other Output Modules.

Setting Up and Removing the Output Module

Setting Up the Output Module

When setting up the Output Modules, pull out the internal mechanism from the housing and insert the Output Modules into the sockets for control outputs 1 and 2.

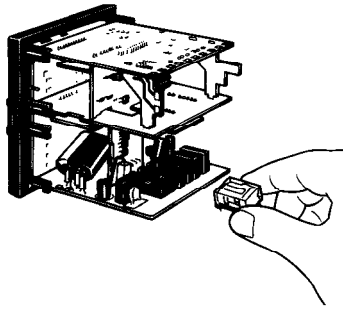

Removing the Output Module

To replace the Output Module, use a flat-blade screwdriver to push up the Output Module.

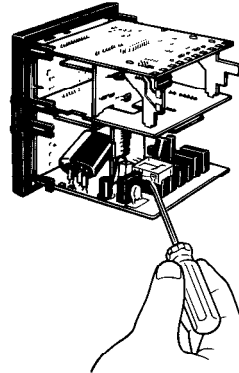

Setting Up the Option/Output Board

E5AK

1. Remove the Power Board and Option Boards in the order shown in the following diagram.
2. Insert the Option Boards into the sockets for options 1 to 3. The following diagram shows the relationship between the Option Boards and mounting positions.

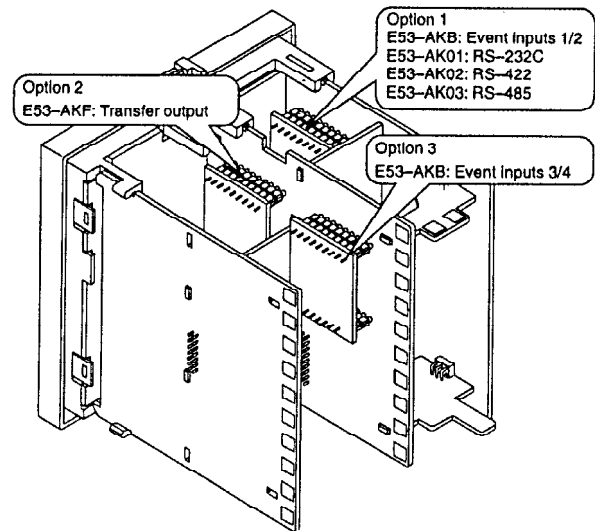
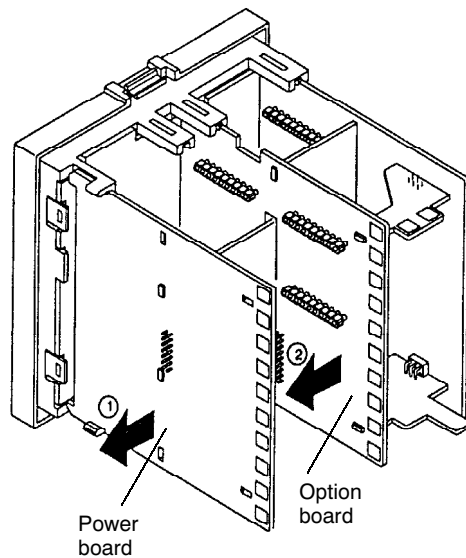

3. Mount the option boards and the power board in the order shown.

E5EK

1. Remove the Power Board in the order shown in the following diagram.

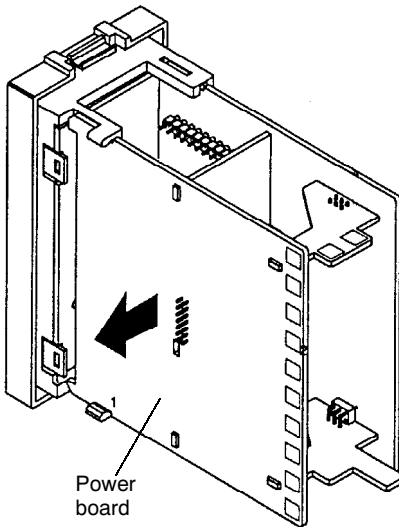

2. Insert the Option Board into the socket for option 1. The following diagram shows the relationship between the Option Board and mounting position.

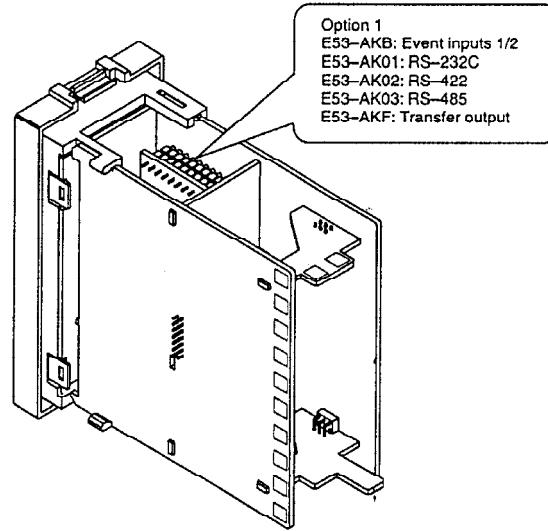

3. Mount the option boards and the power board in the order shown.

E5CK

1. Two rectangular holes are provided on the Power Board (right side of Controller). Fit the two protrusions of the output board into these two holes.
2. With the output board fitted into the Power Board, fit the output board into the connector on the control board (left side of Controller).

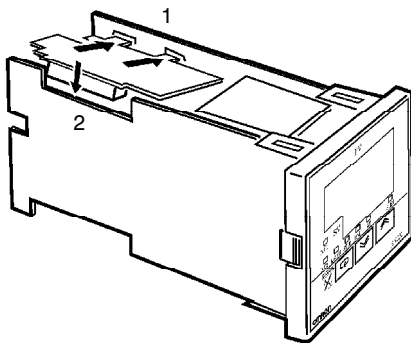

Set up the Option Board

1. Place the bottom of the Controller facing up, fit the board horizontally into the connector on the power board (right side of controller).
2. With the Power Board connected, fit the board vertically into the connector on the control board (left side of Controller).

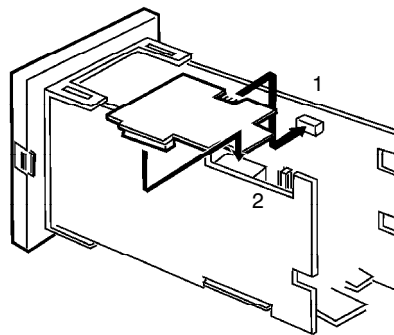

■ Mounting Controller

E5AK and E5EK

1. Insert the controller into the panel's mounting hole at the position shown in the figure below.
2. Fit the mounting bracket (accessory) into the mounting slots on the top and bottom of the rear case.
3. Tighten the mounting bracket screws on the upper and lower parts in small increments alternately and equally until the ratchet start to slide.

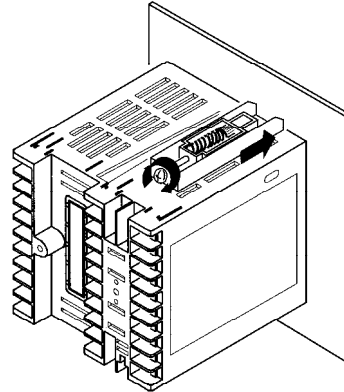
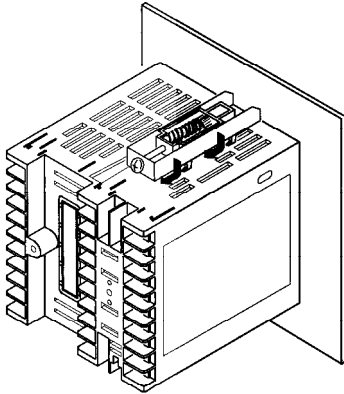

E5CK

1. Insert the E5CK Controller into the cutout on the panel, as shown in the figure here.
2. Push the adapter along the Controller body from the terminals up to the panel, and fasten temporarily.
3. Tighten the two mounting screws on the adapter. When tightening screws, tighten the two screws alternately keeping the torque to approximately 0.29 to $0.39 \text{ N} \cdot \text{m}$, or 3 to $4 \text{ kgf} \cdot \text{cm}$.

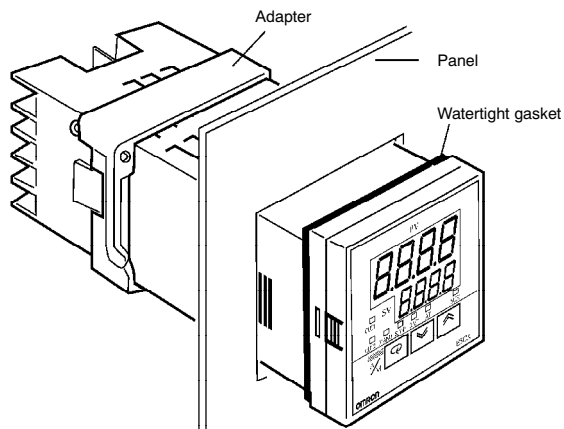

■ Mounting Terminal Cover

E5AK and E5EK

1. Fasten the terminals covers as follows by using the plastic pins. Plastic pins are provided with the terminal covers.

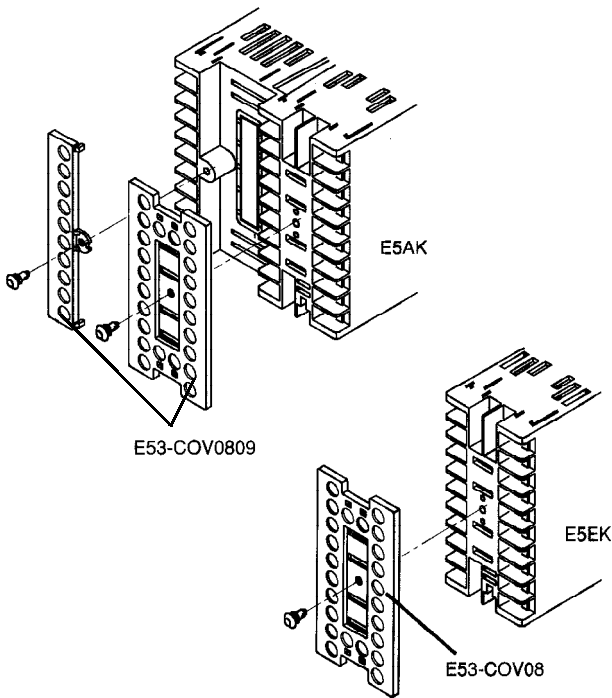

E5CK

1. The E5CK-AA1-500 Controller is provided with a Terminal Cover (E53-COV07). Fasten the Terminal Cover as follows by using the plastic pin.

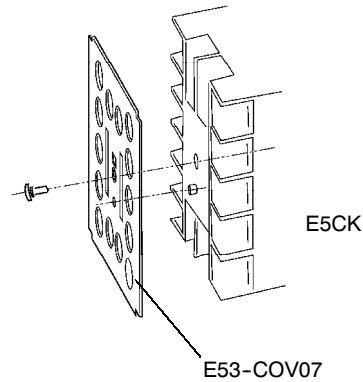

■ Wiring Terminals for E5AK

E5AK Terminal Arrangement

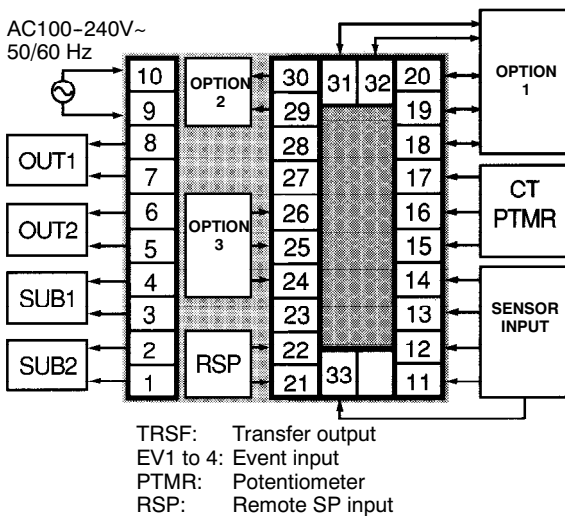

Wiring

In the following wiring diagrams, the left side of the terminal numbers indicate the inside of the Controller.

Power Supply

Input power to terminal numbers 9 and 10. Power specifications are as follows: 100 to 240 VAC, 50/60 Hz, approx. 16 VA

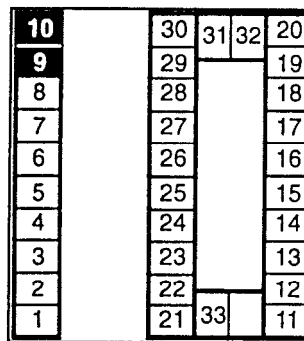

Wiring Terminals for E5EK

E5EK Terminal Arrangement

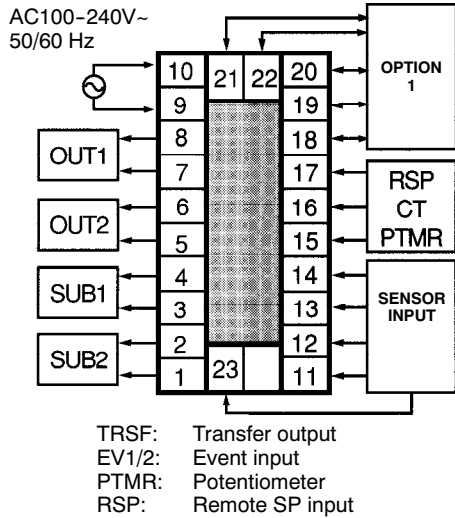

Power supply

Input power to terminal numbers 9 and 10. Power specifications are as follows: 100 to 240 VAC, 50/60 Hz, approx. 15 VA

10	21	22	20
9			19
8			18
7			17
6			16
5			15
4			14
3			13
2			12
1	23		11

Wiring Terminals for E5CK

E5CK Terminal Arrangement

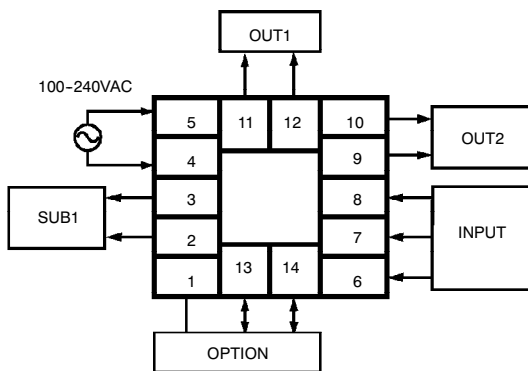

Wiring Precautions

- To protect the Controller and its lines from external noise, use the wire ducts to separate input leads and power lines.
- Use solderless terminals when wiring the Controller.
- Tighten the terminal screws using a torque no greater than 0.78 N • m, or 8 kgf • cm max. DO NOT tighten the terminal screws too tightly.

Power Supply

Input 100 to 240 VAC to terminal numbers 4 and 5.

5	11	12	10
4			9
3			8
2			7
1	13	14	6

Input Wiring

E5AK

Connect the sensor input to terminal numbers 11 to 14 and 33 as follows according to the input type.

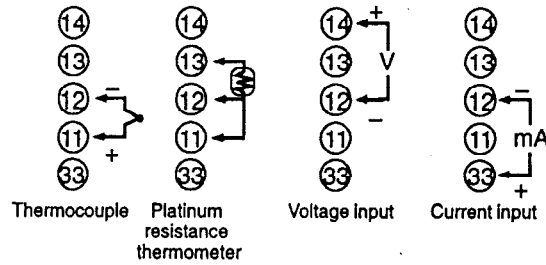
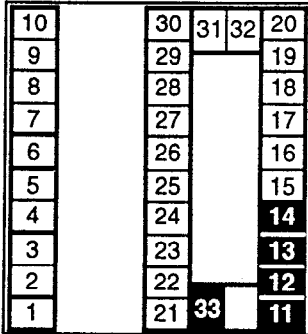

E5EK

Connect the sensor input to terminal numbers 11 to 14 and 23 as follows according to the input type.

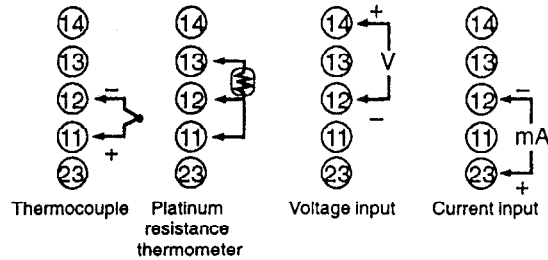
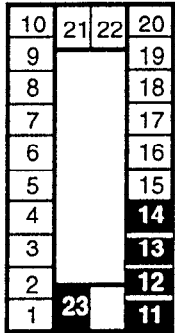

E5CK

Connect the sensor input to terminal numbers 6 to 8 as indicated here, according to the input type.

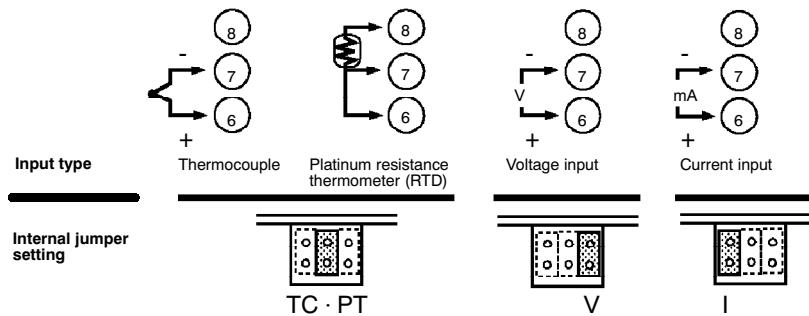
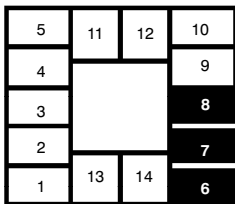

Match the inputs with the internal jumper settings for each input type. For thermocouple or platinum resistance thermometer inputs, set the internal jumper to a common position (TC/PT) as the temperature input.

Control Output

E5AK Control Output

Terminal numbers 7 and 8 are for control output 1 (OUT1), and terminal numbers 5 and 6 are for control output 2 (OUT2). The following diagrams show the available Output Modules and their internal circuits.

10		30	31	32	20
9		29			19
8		28			18
7		27			17
6		26			16
5		25			15
4		24			14
3		23			13
2		22			12
1		21	33		11

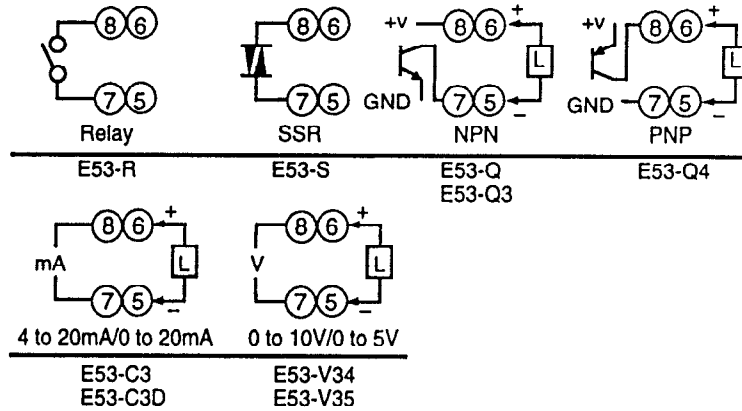

E5EK Control Output

Terminal numbers 7 and 8 are for control output 1 (OUT1), and terminal numbers 5 and 6 are for control output 2 (OUT2). The following diagrams show the available Output Modules and their internal circuits.

10	21	22	20
9			19
8			18
7			17
6			16
5			15
4			14
3			13
2			12
1	23		11

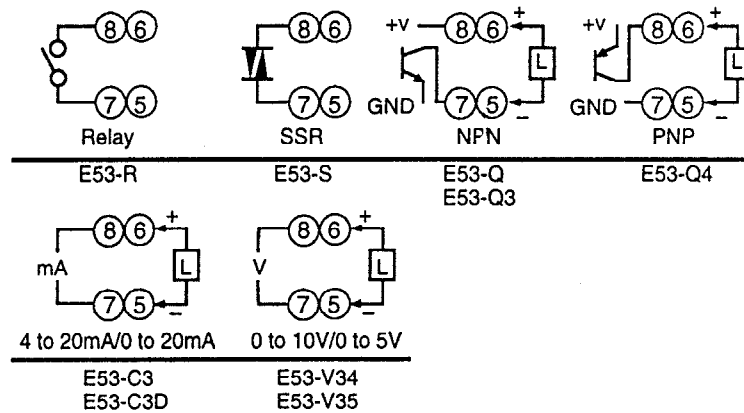

With E53-V□□ Output Modules, approx. 2 V is output for one second after the power is interrupted.

E5AK-PRR2/E5EK-PRR2 Controllers

The E5AK-PRR2 and E5EK-PRR2 Controllers are supplied with relay output. This relay output is not compatible with any other module.

When replacing the Output Module, use the E53-R. The following diagrams show the relationship between terminals and open/close relay settings.

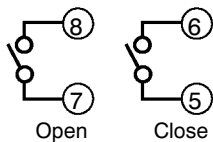

E5CK Control Output

Terminal numbers 11 and 12 are for control output 1 (OUT1). The five output types and internal circuits are available according to the Output Board.

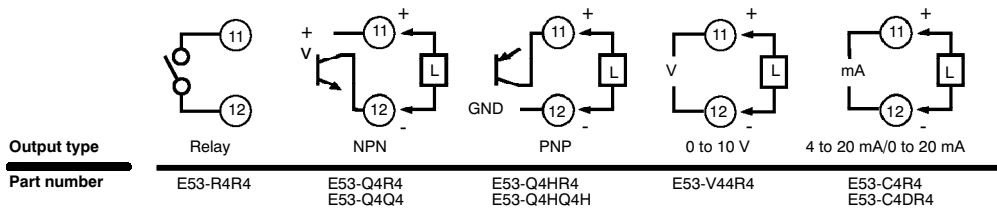
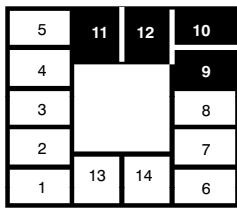

Terminal numbers 9 and 10 are for control output 2 (OUT2). The three output types and internal circuits are available according to the Output Board.

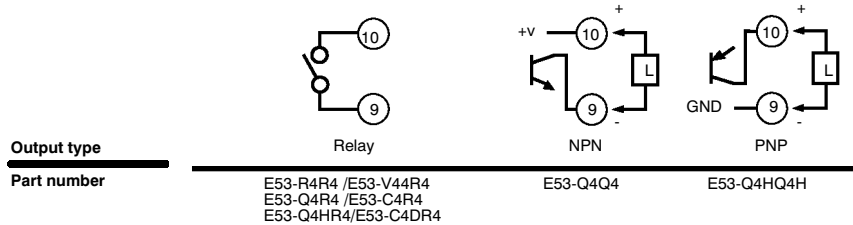

Auxiliary Output

E5AK

Terminal numbers 3 and 4 are for auxiliary output 1 (SUB1) and terminal numbers 1 and 2 are for auxiliary output 2 (SUB2). The following diagrams show the internal equalizing circuits for the auxiliary outputs:

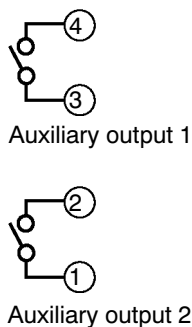
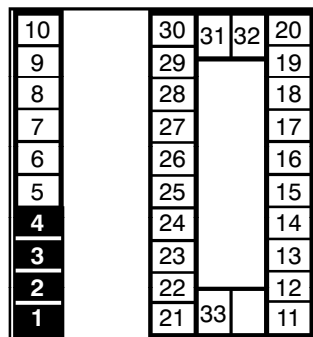

Output specifications are as follows: SPST-NO, 3 A at 250 VAC

E5EK

Terminal numbers 3 and 4 are for auxiliary output 1 (SUB1) and terminal numbers 1 and 2 are for auxiliary output 2 (SUB2). The following diagrams show the internal equalizing circuits for the auxiliary outputs:

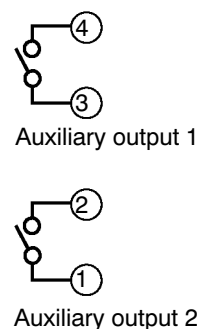
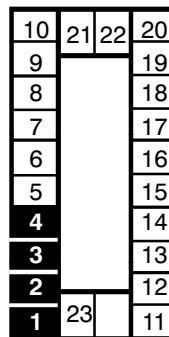

Output specifications are as follows: SPST-NO, 3 A at 250 VAC

E5CK

Terminal numbers 2 and 3 are for auxiliary output 1 (SUB1). The internal equalizing circuit for auxiliary output 1 is as follows:

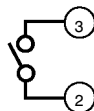
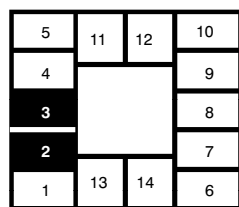

■ CT Input/Potentiometer (for E5AK and E5EK only)

E5AK CT Input/Potentiometer

When using the HBA function on the E5AK-AA2 Controller, connect Current Transformer input (CT) to terminal numbers 15 to 17. When monitoring the valve opening on the E5AK-PRR2 Controller, connect the potentiometer (PTMR) to terminal numbers 15 to 17. Connect each of these inputs as follows:

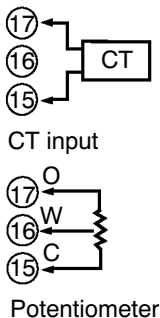
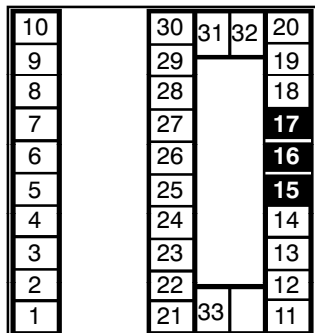

For details on CT inputs, refer to *Appendix, About Current Transformer* in your *User's Manual*. For details on the potentiometer, refer to the *Instruction Manual* for the valve connected to the Controller. The variable resistance range is 100 Ω to 2.5 kΩ.

E5EK CT Input/Potentiometer

When using the HBA function on the E5EK-AA2 Controller, connect Current Transformer input (CT) to terminal numbers 15 to 17. When monitoring the valve opening on the E5EK-PRR2 Controller, connect the potentiometer (PTMR) to terminal numbers 15 to 17. Connect each of these inputs as follows:

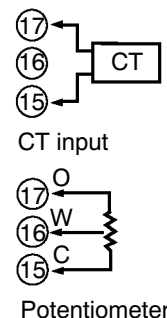
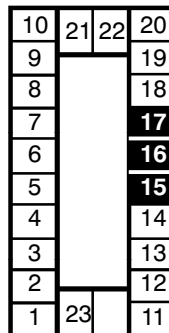

For details on CT inputs, refer to *Appendix, About Current Transformer* in your *User's Manual*. The potentiometer cannot be used simultaneously with remote SP input. For details on the potentiometer, refer to the *Instruction Manual* for the valve connected to the Controller. The variable resistance range is 100 Ω to 2.5 kΩ.

■ Remote Set Point Input (for E5AK and E5EK only)

E5AK Remote SP Input

Connect the input (RSP) to be used as the remote SP to terminal numbers 21 and 22. Only 4 to 20 mA inputs can be connected. Connect the input as follows:

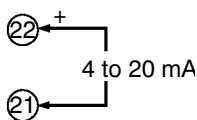
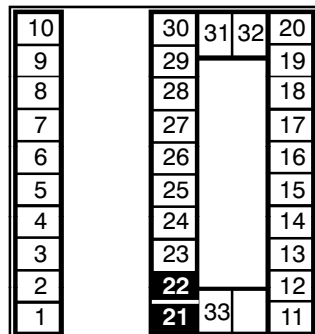

E5EK Remote SP Input

Connect the input (RSP) to be used as the remote SP to terminal numbers 15 and 16. However, note that the potentiometer cannot be used simultaneously with remote SP input. Only 4 to 20 mA inputs can be connected. Connect the input as follows:

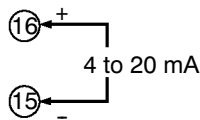
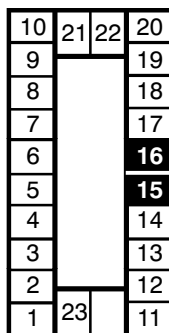

Option Board Wiring

E5AK

Connect event inputs 1 and 2 (EV1/2) to terminal numbers 18 to 20, and event events 3 and 4 (EV3/4) to terminal numbers 24 to 26. However, note that terminal numbers 18 to 20 cannot be used on Controllers with a communications function. Connect the event inputs as follows:

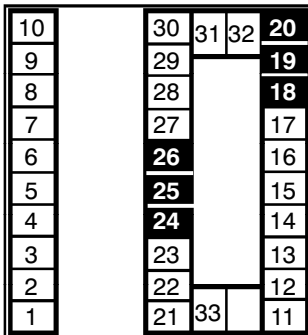

Terminals 18 and 24 (COM) are connected internally.

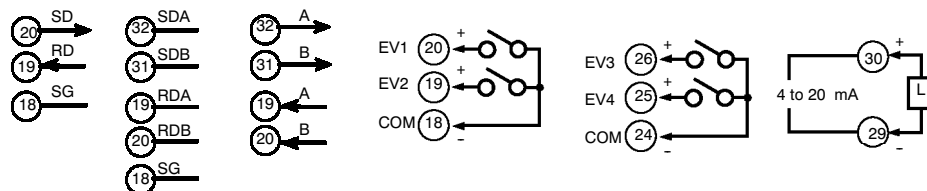

Option type	RS-232C	RS-422	RS-485	Event input 1 and 2 (no contact)	Event input 3 and 4 (no contact)	Transfer output
Part number	E53-AK01	E53-AK02	E53-AK03			

Use event inputs under the following conditions:

Contact input	ON: 1 k Ω max. OFF: 100 k Ω min.
No-contact input	ON: Residual voltage 1.5 V max., OFF: Leakage current 0.1 mA max.

Communications

Terminal numbers 18 to 20, 31 and 32 can be used only on Controllers with Communications Units (E53-AK01/02/03). For details on wiring, refer to *Chapter 6, Using the Communications Function* in your *User's Manual*.

E5EK

Connect event inputs 1 and 2 (EV1/2) to terminal numbers 18 to 20. However, note that terminal numbers 18 to 20 cannot be used on Controllers with a communications function. Connect the event inputs as follows:

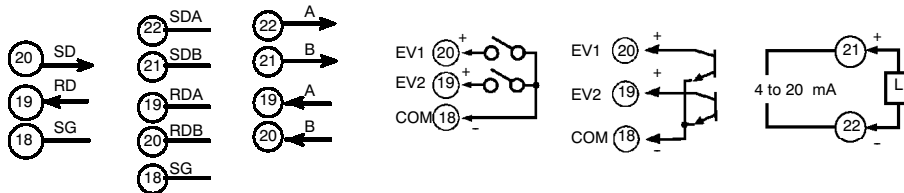
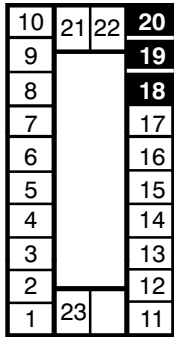

Option type	RS-232C	RS-422	RS-485	Event input 1 and 2	Event input 1 and 2 (no contact)	Transfer output
Part number	E53-AK01	E53-AK02	E53-AK03	E53-AKB	E53-AKB	E53-AKF

Use event inputs under the following conditions:

Contact input	ON: 1 kΩ max., OFF: 100 kΩ min.
No-contact input	ON: Residual voltage 1.5 V max., OFF: Leakage current 0.1 mA max.

Communications

Terminal numbers 18 to 20, 31 and 32 can be used only on Controllers with Communications Units (E53-AK01/02/03). For details on wiring, refer to *Chapter 6, Using the Communications Function* in your *User's Manual*.

E5CK

Terminal numbers 1, 13, and 14 are valid only when the Option Board is set in the Controller

The following four connections are possible depending on the model of the Option Board.

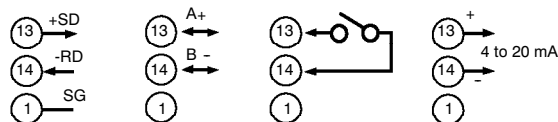
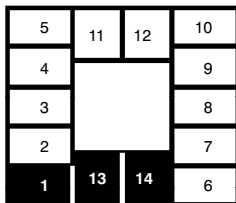

Option type	RS-232C	RS-485	Event input	Transfer output
Part number	E53-CK01	E53-CK03	E53-CKB	E53-CKF

■ Connection Example of Digital Controller And SSR

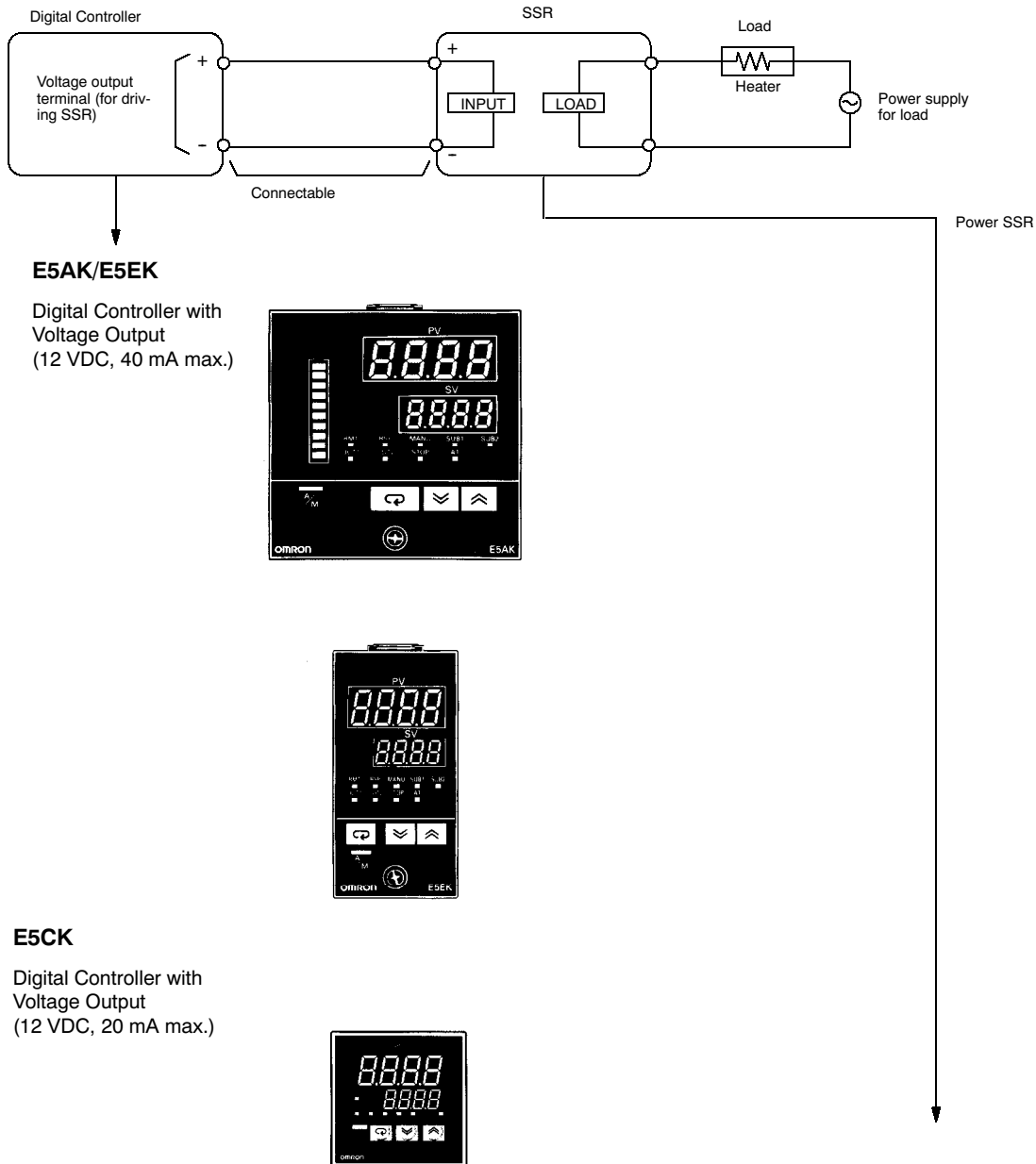

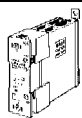
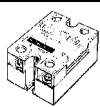
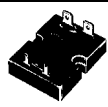
Model	G3PA/G3PB	G3NA	G3NE
Appearance			
SSRs connected in parallel	E5AK/E5EK: 8 pcs. E5CK: 4 pcs.	E5AK/E5EK: 5 pcs. E5CK: 2 pcs.	E5AK/E5EK: 2 pcs. E5CK: 1 piece
Rated input voltage	5 to 24 VDC	5 to 24 VDC	12 VDC
Features	Thin, SSR with built-in heat sink; 1-phase and 3-phase models	Standard model with screw terminals	Compact, low-cost model with tab terminals

Precautions

Precautions when Wiring

- Use wire ducts to separate input leads and power lines in order to protect the Controller and its lines from external noise.
- Solderless terminals are recommended when wiring the Controller.
- Tighten the terminal screws using a torque no greater than 0.78 N • m, or 8 kgf • cm max. Take care not to tighten the terminal screws too tightly.

Power Blocks

The E5AK/E5EK has independent power supplies for each of the terminal blocks shown below.

E5AK

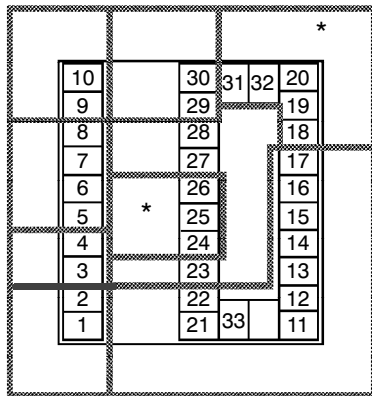

E5EK

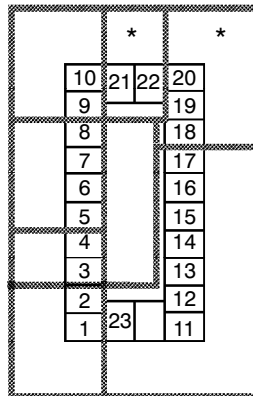

E5CK

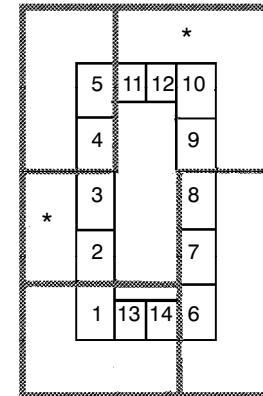

* Uses same internal power supply

Note: Terminals 21 and 22 of the E5EK belong to the B block when a transfer output is set to option 1 and to the C block for other Option Boards.

Operating Environment

- Keep within the rated ambient operating temperature, ambient operating humidity, and storage temperature ranges.
- Use the Unit according to the vibration resistance, shock resistance, and enclosure ratings.
- Do not use the Unit in places with corrosive gas or excessive dust.
- Do not use the Unit near machines generating high-frequency noise.

Correct Use

Mounting

- The dimensions of the Digital Controller conform to DIN 43700.
- Recommended panel thickness is 1 to 8 mm.
- Mount the Unit horizontally.

Connection

- To reduce inductive noise influence, the lead wires connecting the input type to the Digital Controller must be separated from the power lines and load lines.
- Use the specified compensating conductors for thermocouples. Use lead wires having a small resistance for platinum resistance thermometers.

Connection Example

- Wire the terminals of the Unit using solderless terminals.
- The tightening torque applied to the terminal screws of the Unit must be approximately 0.78 N • m or 8 kgf • cm.

Use the following type of solderless terminals for M3.5 screws.

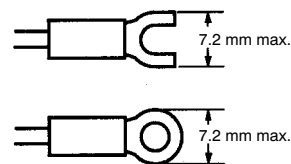

■ Operation

- For models with alarm functions: The alarm outputs of a model with an alarm function may not turn ON properly when the model malfunctions. The use of alarm equipment with the model is recommended.
- The parameters and internal switch are set before shipping so that the Unit will function normally. Change the settings of the parameters and internal switch according to the application, if necessary.
- Several seconds are required until the relay is turned ON after power has been supplied to the Digital Controller. You must take this time delay into consideration when designing sequenced circuits which incorporate a Digital Controller.
- Do not use excessive force when pulling out the internal mechanism from the housing. Protect the internal connector or electronic parts of the Unit from shock. Protect against static discharge when changing the settings of the internal switch. Changing the settings on a grounded conductive mat is recommended.
- When connecting the Control Output Unit to the Temperature Controller or Digital Controller, make sure that the Control Output Unit is a suitable type. The use of an improper type of Control Output Unit may cause the system to malfunction.
- The heater burnout alarm will not be available if the Linear Output Unit is used.

Certain Terms and Conditions of Sale

1. **Offer; Acceptance.** These terms and conditions (these "Terms") are deemed part of all catalogs, manuals or other documents, whether electronic or in writing, relating to the sale of goods or services (collectively, the "Goods") by Omron Electronics LLC and its subsidiary companies ("Seller"). Seller hereby objects to any terms or conditions proposed in Buyer's purchase order or other documents which are inconsistent with, or in addition to, these Terms. Please contact your Omron representative to confirm any additional terms for sales from your Omron company.
2. **Prices.** All prices stated are current, subject to change without notice by Seller. Buyer agrees to pay the price in effect at time of shipment.
3. **Discounts.** Cash discounts, if any, will apply only on the net amount of invoices sent to Buyer after deducting transportation charges, taxes and duties, and will be allowed only if (i) the invoice is paid according to Seller's payment terms and (ii) Buyer has no past due amounts owing to Seller.
4. **Orders.** Seller will accept no order less than \$200 net billing.
5. **Governmental Approvals.** Buyer shall be responsible for, and shall bear all costs involved in, obtaining any government approvals required for the importation or sale of the Goods.
6. **Taxes.** All taxes, duties and other governmental charges (other than general real property and income taxes), including any interest or penalties thereon, imposed directly or indirectly on Seller or required to be collected directly or indirectly by Seller for the manufacture, production, sale, delivery, importation, consumption or use of the Goods sold hereunder (including customs duties and sales, excise, use, turnover and license taxes) shall be charged to and remitted by Buyer to Seller.
7. **Financial.** If the financial position of Buyer at any time becomes unsatisfactory to Seller, Seller reserves the right to stop shipments or require satisfactory security or payment in advance. If Buyer fails to make payment or otherwise comply with these Terms or any related agreement, Seller may (without liability and in addition to other remedies) cancel any unshipped portion of Goods sold hereunder and stop any Goods in transit until Buyer pays all amounts, including amounts payable hereunder, whether or not then due, which are owing to it by Buyer. Buyer shall in any event remain liable for all unpaid accounts.
8. **Cancellation; Etc.** Orders are not subject to rescheduling or cancellation unless Buyer indemnifies Seller fully against all costs or expenses arising in connection therewith.
9. **Force Majeure.** Seller shall not be liable for any delay or failure in delivery resulting from causes beyond its control, including earthquakes, fires, floods, strikes or other labor disputes, shortage of labor or materials, accidents to machinery, acts of sabotage, riots, delay in or lack of transportation or the requirements of any government authority.
10. **Shipping; Delivery.** Unless otherwise expressly agreed in writing by Seller:
 - a. Shipments shall be by a carrier selected by Seller;
 - b. Such carrier shall act as the agent of Buyer and delivery to such carrier shall constitute delivery to Buyer;
 - c. All sales and shipments of Goods shall be FOB shipping point (unless otherwise stated in writing by Seller), at which point title to and all risk of loss of the Goods shall pass from Seller to Buyer, provided that Seller shall retain a security interest in the Goods until the full purchase price is paid by Buyer;
 - d. Delivery and shipping dates are estimates only.
 - e. Seller will package Goods as it deems proper for protection against normal handling and extra charges apply to special conditions.
11. **Claims.** Any claim by Buyer against Seller for shortage or damage to the Goods occurring before delivery to the carrier must be presented in writing to Seller within 30 days of receipt of shipment and include the original transportation bill signed by the carrier noting that the carrier received the Goods from Seller in the condition claimed.
12. **Warranties.** (a) **Exclusive Warranty.** Seller's exclusive warranty is that the Goods will be free from defects in materials and workmanship for a period of twelve months from the date of sale by Seller (or such other period expressed in writing by Seller). Seller disclaims all other warranties, express or implied. (b) **Limitations.** SELLER MAKES NO WARRANTY OR REPRESENTATION, EXPRESS OR IMPLIED, ABOUT NON-INFRINGEMENT, MERCHANTABILITY OR FITNESS FOR A PARTICULAR PURPOSE OF THE GOODS. BUYER ACKNOWLEDGES THAT IT ALONE HAS DETERMINED THAT THE GOODS WILL SUITABLY MEET THE REQUIREMENTS OF THEIR INTENDED USE. Seller further disclaims all warranties and responsibility of any type for claims or expenses based on infringement by the Goods or otherwise of any intellectual property right. (c) **Buyer Remedy.** Seller's sole obligation hereunder shall be to replace (in the form originally shipped with Buyer responsible for labor charges for removal or replacement thereof) the non-complying Good or, at Seller's election, to repay or credit Buyer an amount equal to the purchase price of the Good; provided that in no event shall Seller be responsible for warranty, repair, indemnity or any other claims or expenses regarding the Goods unless Seller's analysis confirms that the Goods were properly handled, stored, installed and maintained and not subject to contamination, abuse, misuse or inappropriate modification. Return of any goods by Buyer must be approved in writing by Seller before shipment. Seller shall not be liable for the suitability or unsuitability or the results from the use of Goods in combination with any electrical or electronic components, circuits, system assemblies or any other materials or substances or environments. Any advice, recommendations or information given orally or in writing, are not to be construed as an amendment or addition to the above warranty.
13. **Damage Limits; Etc.** SELLER SHALL NOT BE LIABLE FOR SPECIAL, INDIRECT OR CONSEQUENTIAL DAMAGES, LOSS OF PROFITS OR PRODUCTION OR COMMERCIAL LOSS IN ANY WAY CONNECTED WITH THE GOODS, WHETHER SUCH CLAIM IS BASED IN CONTRACT, WARRANTY, NEGLIGENCE OR STRICT LIABILITY. Further, in no event shall liability of Seller exceed the individual price of the Good on which liability is asserted.
14. **Indemnities.** Buyer shall indemnify and hold harmless Seller, its affiliates and its employees from and against all liabilities, losses, claims, costs and expenses (including attorney's fees and expenses) related to any claim, investigation, litigation or proceeding (whether or not Seller is a party) which arises or is alleged to arise from Buyer's acts or omissions under these Terms or in any way with respect to the Goods. Without limiting the foregoing, Buyer (at its own expense) shall indemnify and hold harmless Seller and defend or settle any action brought against Seller to the extent that it is based on a claim that any Good made to Buyer specifications infringed intellectual property rights of another party.
15. **Property; Confidentiality.** The intellectual property embodied in the Goods is the exclusive property of Seller and its affiliates and Buyer shall not attempt to duplicate it in any way without the written permission of Seller. Notwithstanding any charges to Buyer for engineering or tooling, all engineering and tooling shall remain the exclusive property of Seller. All information and materials supplied by Seller to Buyer relating to the Goods are confidential and proprietary, and Buyer shall limit distribution thereof to its trusted employees and strictly prevent disclosure to any third party.
16. **Miscellaneous.** (a) **Waiver.** No failure or delay by Seller in exercising any right and no course of dealing between Buyer and Seller shall operate as a waiver of rights by Seller. (b) **Assignment.** Buyer may not assign its rights hereunder without Seller's written consent. (c) **Amendment.** These Terms constitute the entire agreement between Buyer and Seller relating to the Goods, and no provision may be changed or waived unless in writing signed by the parties. (d) **Severability.** If any provision hereof is rendered ineffective or invalid, such provision shall not invalidate any other provision. (e) **Setoff.** Buyer shall have no right to set off any amounts against the amount owing in respect of this invoice. (f) As used herein, "including" means "including without limitation".

Certain Precautions on Specifications and Use

1. **Suitability of Use.** Seller shall not be responsible for conformity with any standards, codes or regulations which apply to the combination of the Good in the Buyer's application or use of the Good. At Buyer's request, Seller will provide applicable third party certification documents identifying ratings and limitations of use which apply to the Good. This information by itself is not sufficient for a complete determination of the suitability of the Good in combination with the end product, machine, system, or other application or use. The following are some examples of applications for which particular attention must be given. This is not intended to be an exhaustive list of all possible uses of this Good, nor is it intended to imply that the uses listed may be suitable for this Good:
 - (i) Outdoor use, uses involving potential chemical contamination or electrical interference, or conditions or uses not described in this document.
 - (ii) Energy control systems, combustion systems, railroad systems, aviation systems, medical equipment, amusement machines, vehicles, safety equipment, and installations subject to separate industry or government regulations.
 - (iii) Systems, machines and equipment that could present a risk to life or property. Please know and observe all prohibitions of use applicable to this Good.
2. **Programmable Products.** Seller shall not be responsible for the user's programming of a programmable Good, or any consequence thereof.
3. **Performance Data.** Performance data given in this catalog is provided as a guide for the user in determining suitability and does not constitute a warranty. It may represent the result of Seller's test conditions, and the user must correlate it to actual application requirements. Actual performance is subject to the Seller's Warranty and Limitations of Liability.
4. **Change in Specifications.** Product specifications and accessories may be changed at any time based on improvements and other reasons. It is our practice to change part numbers when published ratings or features are changed, or when significant construction changes are made. However, some specifications of the Good may be changed without any notice. When in doubt, special part numbers may be assigned to fix or establish key specifications for your application. Please consult with your Seller's representative at any time to confirm actual specifications of purchased Good.
5. **Errors and Omissions.** The information in this catalog has been carefully checked and is believed to be accurate; however, no responsibility is assumed for clerical, typographical or proofreading errors, or omissions.

NEVER USE THE PRODUCT FOR AN APPLICATION INVOLVING SERIOUS RISK TO LIFE OR PROPERTY WITHOUT ENSURING THAT THE SYSTEM AS A WHOLE HAS BEEN DESIGNED TO ADDRESS THE RISKS, AND THAT THE SELLER'S PRODUCT IS PROPERLY RATED AND INSTALLED FOR THE INTENDED USE WITHIN THE OVERALL EQUIPMENT OR SYSTEM.

Complete "Terms and Conditions of Sale" for product purchase and use are on Omron's website at www.omron.com/oei – under the "About Us" tab, in the Legal Matters section.

ALL DIMENSIONS SHOWN ARE IN MILLIMETERS.

To convert millimeters into inches, multiply by 0.03937. To convert grams into ounces, multiply by 0.03527.

OMRON[®]**OMRON ELECTRONICS LLC**

One Commerce Drive
Schaumburg, IL 60173

847-843-7900

For US technical support or other inquiries:

800-556-6766**OMRON CANADA, INC.**

885 Milner Avenue
Toronto, Ontario M1B 5V8

416-286-6465**OMRON ON-LINE**

Global - <http://www.omron.com>
USA - <http://www.omron.com/oei>
Canada - <http://www.omron.ca>