

② USB3.0 COMPLIANT

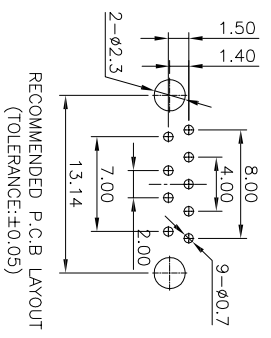
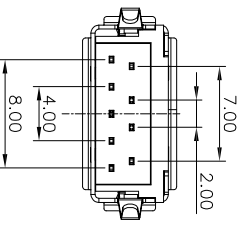
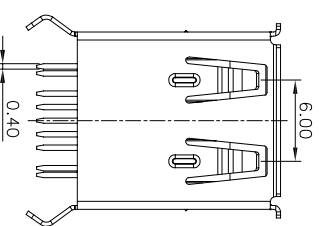
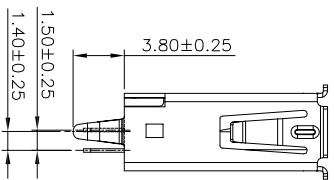
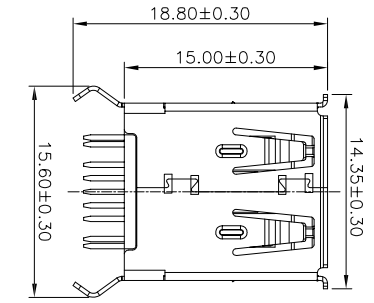
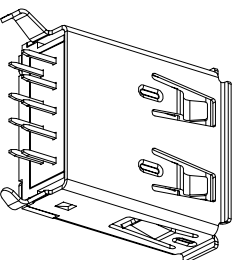
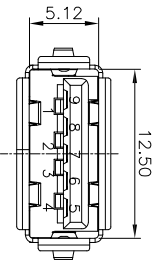

- NOTES:
- MATERIAL:
 - HOUSING: PBT+30%G.F UL94V-0,BLUE COLOR.
 - COVER: PBT+50%G.F UL94V-0,BLUE COLOR.
 - CONTACT: COPPER ALLOY T=0.25MM
 - SHELL: BRASS T=0.30MM
 - FINISH:
 - CONTACT: CONTACT AREA: 15u"Au
 - SOLDER AREA: TIN PLATED
 - UNDER PLATE: NI PLATED
 - MECHANICAL:
 - MATING FORCE: 3.57kgf MAX.
 - UNMATING FORCE: 1.02kgf MIN
 - DURABILITY: 1500 CYCLES MIN
 - ELECTRICAL:
 - CURRENT RATING:1.8A FOR PIN1 TO PIN4. 0.25A OTHER CONTACTS.
 - DIELECTRIC STRENGTH: 100V AC FOR 1MINUTE.
 - CONTACT RESISTANCE: 20mΩ MAX FOR PIN1 TO PIN4. 50mΩ MAX OTHER CONTACTS.
 - INSULATION RESISTANCE: 100MΩ MIN
 - OPERATING TEMPERATURE: -55°C TO +85°C.

RoHS compliant
unit:mm

Scale	FREE						
TOLERANCE							
X.X	±0.38						
X.XX	±0.25						
X.XXX	±0.10	②	Add the"USB3.0 COMPLIANT"	24.03.2014	Wlrnlr		
DIM	TOL	①	Update	18.02.2014	Ray		
X.°	±5°	①	Drawn	29.07.2011	Rale		
Angle	TOL						

Date	Name	Date	Name
29.07.2011	Rale	24.03.2014	Wlrnlr

Customer-No.	ASSMANN WSW-No.	Drawing-No.	Replace
	A-USB3 A-TOP		ASS 4544 CO
			rev02
			Sheet