

Type 1XK Wi-Fi® + Bluetooth® Module

NXP IW416 Chipset for 802.11a/b/g/n + Bluetooth 5.2
Datasheet - Rev. R

- Design Name: Type 1XK
- P/N: LBEE5CJ1XK-687

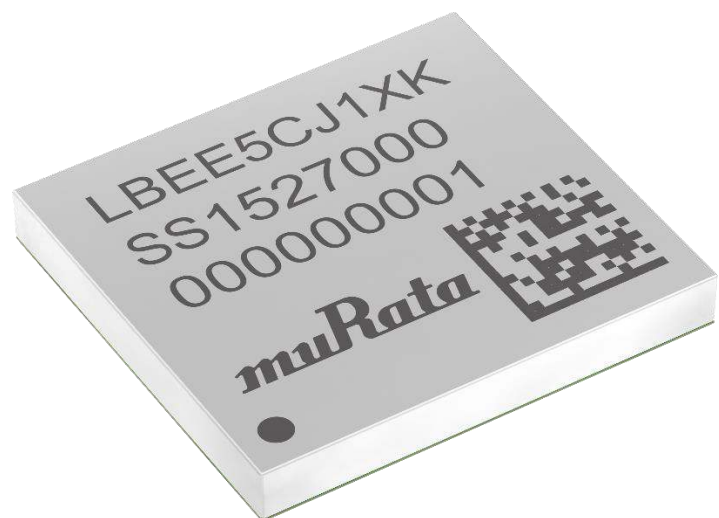

Table of Contents

1 Scope	8
2 Key Features	8
3 Ordering Information	8
4 Block Diagram	9
5 Certification Information	10
5.1 Radio Certification.....	10
5.2 Bluetooth Qualification	10
6 Dimensions, Markings and Terminal Configurations	11
7 Module Pin Descriptions	12
7.1 Pin Assignments	12
7.2 Pin Descriptions	13
7.3 Configuration Pins.....	16
7.4 Pin States	17
8 Absolute Maximum Ratings	19
9 Operating Conditions	19
9.1 Operating Conditions	19
9.2 External Sleep Clock Requirements.....	19
9.3 Digital I/O Requirements	20
9.4 Package Thermal Conditions	20
10 Power Sequence	21
10.1 Power-On Sequence.....	21
10.2 Power-Off Sequence.....	22
10.2.1 Power-Off Sequence	22
10.2.2 Host Power Off Pin (PMIC_EN) Usage.....	22
11 Interface Timing	23
11.1 SDIO Timing	23
11.1.1 Default Speed Mode.....	23
11.1.2 High Speed Mode.....	23
11.1.3 SDR12, SDR25, and SDR50 Modes up to 100 MHz (1.8 V)	24
11.1.4 DDR50 Mode at 50 MHz (1.8V)	25
11.2 UART Timing (Default Mode)	26
11.3 Bluetooth PCM Timing	27
11.3.1 Master Mode	27
11.3.2 Slave Mode	28
12 DC/RF Characteristics	29

12.1 DC/RF Characteristics for IEEE 802.11b - 2.4 GHz.....	30
12.1.1 High-Rate Condition for IEEE 802.11b - 2.4 GHz	30
12.1.2 Low-Rate Condition for IEEE 802.11b - 2.4 GHz	31
12.2 DC/RF Characteristics for IEEE 802.11g - 2.4 GHz.....	32
12.2.1 High-Rate Condition for IEEE 802.11g - 2.4 GHz	32
12.2.2 Low-Rate Condition for IEEE 802.11g - 2.4 GHz	33
12.3 DC/RF Characteristics for IEEE 802.11n (HT20) - 2.4 GHz.....	34
12.3.1 High-Rate Condition for IEEE 802.11n (HT20) - 2.4 GHz	34
12.3.2 Low-Rate Condition for IEEE 802.11n (HT20) - 2.4 GHz	35
12.4 DC/RF Characteristics for IEEE 802.11a - 5 GHz.....	35
12.4.1 High-Rate Condition for IEEE 802.11a - 5 GHz	36
12.4.2 Low-Rate Condition for IEEE 802.11a - 5 GHz	37
12.5 DC/RF Characteristics for IEEE 802.11n (HT20) - 5 GHz.....	38
12.5.1 High-Rate Condition for IEEE 802.11n (HT20) - 5 GHz	38
12.5.2 Low-Rate Condition for IEEE 802.11n (HT20) - 5 GHz	39
12.6 DC/RF Characteristics for IEEE 802.11n (HT40) - 5 GHz.....	40
12.6.1 High-Rate Condition for IEEE 802.11n (HT40) - 5 GHz	40
12.6.2 Low-Rate Condition for IEEE 802.11n (HT40) - 5 GHz	41
12.7 DC/RF Characteristics for Bluetooth.....	42
12.7.1 Basic Data Rate Condition.....	42
12.7.2 Enhanced Data Rate Condition	43
12.8 DC/RF Characteristics for Bluetooth Low Energy	44
12.8.1 1 Mbps PHY Condition	44
12.8.2 2 Mbps PHY Condition	45
13 Land Pattern	47
14 General Radio Regulatory Certification for LBEE5CJ1XK and LBEE5CJ2XK	48
14.1 Application Model Part Number.....	48
14.2 Label.....	48
14.3 Package Label	49
14.4 Country of Origin	50
15 Radio Regulatory Certification by Country for LBEE5CJ1XK and LBEE5CJ2XK.....	50
15.1 Japan.....	50
15.1.1 Power Level for Japan.....	51
15.1.2 Theory of Operation for Japan.....	52
15.1.3 Antenna List	52
15.1.4 About Notations.....	54
15.1.5 Model Number Change	55

15.2 FCC	56
15.2.1 Information to Display on Host Device and User Manual	56
15.2.2 Equipment Installation for FCC	57
15.2.3 Compliance with FCC Requirement 15.407(c)	57
15.2.4 Product Dimensions	58
15.2.5 Supply Voltage	59
15.2.6 Temperature	59
15.2.7 Power Level for FCC	59
15.2.8 Theory of Operation for FCC	60
15.2.9 About LBEE5CJ1XK and LBEE5CJ2XK	61
15.3 ISED	62
15.3.1 Information to Display on Host Device and User Manual	62
15.3.2 Antenna Installation in End Product	63
15.3.3 Equipment Installation for ISED	64
15.3.4 Power Level for ISED	64
15.3.5 Theory of Operation for ISED	65
15.4 Europe	66
15.4.1 Power Level for Europe	66
15.4.2 Theory of Operation for Europe	67
16 Tape and Reel Packing	68
16.1 Dimensions of Tape (Plastic Tape)	68
16.2 Dimension of Reel	69
16.3 Taping Diagrams	70
16.4 Leader and Tail Tape	71
16.5 Packaging (Humidity Proof Packing)	72
17 Notice	73
17.1 Storage Conditions	73
17.2 Handling Conditions	73
17.3 Standard PCB Design (Land Pattern and Dimensions):	73
17.4 Notice for Chip Placer	74
17.5 Soldering Conditions	74
17.6 Cleaning	74
17.7 Operational Environment Conditions	75
18 Preconditions to Use Our Products	76
Revision History	78

Figures

Figure 1: Block Diagram	9
Figure 2: Dimensions, Markings and Terminal Configurations	11
Figure 3: Structure	12
Figure 4: Pin Assignments Top View	12
Figure 5: SDIO Pins	18
Figure 6: Package Thermal Conditions	20
Figure 7: Power-On Sequence Graph	21
Figure 8: Power-Off Sequence Graph	22
Figure 9: Host Power Off Pin (PMIC_EN) Usage Graph	22
Figure 10: SDIO Protocol Timing Diagram - Default Speed Mode	23
Figure 11: SDIO Protocol Timing Diagram - High Speed Mode	23
Figure 12: SDIO Protocol Timing Diagram - SDR12, SDR25, and SDR50 Modes	24
Figure 13: SDIO CMD Timing Diagram - DDR50 Mode	25
Figure 14: SDIO DATA Timing Diagram - DDR50 Mode	25
Figure 15: UART Timing Diagram	26
Figure 16: Bluetooth Data Signal - Master Mode	27
Figure 17: Bluetooth PCM_SYNC Signal - Master Mode	27
Figure 18: Bluetooth Data Signal - Slave Mode	28
Figure 19: Bluetooth PCM_Sync Signal - Slave Mode	28
Figure 20: Burst Current Definition	29
Figure 21: Land Pattern	47
Figure 22: Radio Regulatory Certification Label	48
Figure 23: Package Label (Humidity Proof Packing)	49
Figure 24: Package Label Display Example	49
Figure 25: Shared Bluetooth/WLAN Antenna and Dedicated Bluetooth/WLAN Antenna	55
Figure 26: Product Dimension	58
Figure 27: Antenna Configuration for Type 1XK and Type 2XK Modules	61
Figure 28: Dimensions of Tape (Unit: mm)	68
Figure 29: Dimensions of Reel (Unit: mm)	69
Figure 30: Taping Diagrams	70
Figure 31: Leader and Tail Tape	71
Figure 32: Peeling Force	71
Figure 33: Humidity Proof Packaging	72
Figure 34: Reflow Soldering Standard Conditions (Example)	74

Tables

Table 1: Document Conventions	7
Table 2: Ordering Information	8
Table 3: Transmit Power Limit Files	10
Table 4: Markings	11
Table 5: Dimensions	11
Table 6: Terminal Configurations	13
Table 7: Pin Descriptions	13
Table 8: Configuration Pins	16
Table 9: Configuration Functions for Wi-Fi and Bluetooth/LE	17
Table 10: I/O State Table	17
Table 11: SDIO Pin Descriptions	18
Table 12: Absolute Maximum Ratings	19
Table 13: Operating Conditions	19
Table 14: External Sleep Clock Requirements	19
Table 15: Digital I/O Requirements Parameters	20
Table 16: Power-On Sequence Parameters	21
Table 17: Power-Off Sequence Parameters	22
Table 18: Host Power Off Pin (PMIC_EN) Usage Parameters	22
Table 19: SDIO Timing Data - High Speed Mode	23
Table 20: SDIO Protocol Timing Parameters - SDR12, SDR25, and SDR50 Modes	24
Table 21: SDIO Protocol Timing Parameters - DDR50 Mode	26
Table 22: UART Timing Data	27
Table 23: Symbol Definition for Data Signal & PCM_SYNC Signal - Master Mode	28
Table 24: Symbol Definition for Data Signal & PCM_SYNC Signal - Slave Mode	29
Table 25: DC/RF Characteristics and Files	29
Table 26: Characteristics Values for IEEE 802.11b - 2.4 GHz	30
Table 27: High-Rate Condition for IEEE 802.11b - 2.4 GHz	30
Table 28: Low-Rate Condition for IEEE 802.11b - 2.4 GHz	31
Table 29: Characteristics Values for IEEE 802.11g - 2.4 GHz	32
Table 30: High-Rate Condition for IEEE 802.11g - 2.4 GHz	32
Table 31: Low-Rate Condition for IEEE 802.11g - 2.4 GHz	33
Table 32: Characteristics Values for IEEE 802.11n (HT20) - 2.4 GHz	34
Table 33: High-Rate Condition for IEEE 802.11n (HT20) - 2.4 GHz	34
Table 34: Low-Rate Condition for IEEE 802.11n (HT20) - 2.4 GHz	35
Table 35: Characteristics Values for IEEE 802.11a - 5 GHz	35
Table 36: High-Rate Condition for IEEE 802.11a - 5 GHz	36
Table 37: Low-Rate Condition for IEEE 802.11a - 5 GHz	37
Table 38: Characteristics Values for IEEE 802.11n (HT20) - 5 GHz	38
Table 39: High-Rate Condition for IEEE 802.11n (HT20) - 5 GHz	38

Table 40: Low-Rate Condition for IEEE 802.11n (HT20) - 5 GHz.....	39
Table 41: Characteristics Values for IEEE 802.11n (HT40) - 5 GHz.....	40
Table 42: High-Rate Condition for IEEE 802.11n (HT40) - 5 GHz.....	40
Table 43: Low-Rate Condition for IEEE 802.11n (HT40) - 5 GHz.....	41
Table 44: Characteristics Values for Bluetooth	42
Table 45: Basic Data Rate Condition	42
Table 46: Enhanced Data Rate Condition.....	43
Table 47: Characteristics Values for BLE.....	44
Table 48: 1 Mbps PHY Condition.....	44
Table 49: 2 Mbps PHY Condition.....	45
Table 50: Japan Power Level 2.4 GHz WLAN Per Antenna Port	51
Table 51: Japan Power Level 2.4 GHz BT/BLE Per Antenna Port	51
Table 52: Japan Power Level 5 GHz WLAN Per Antenna Port	51
Table 53: Japan Theory of Operation for WLAN	52
Table 54: Japan Theory of Operation for Bluetooth.....	52
Table 55: Detail of Notification to MIC.....	55
Table 56: Antenna List.....	56
Table 57: Dimensions	58
Table 58: Supply Voltage.....	59
Table 59: Temperature	59
Table 60: FCC Power Level 2.4 GHz WLAN Per Antenna Port.....	59
Table 61: FCC Power Level 2.4 GHz BT/BLE Per Antenna Port.....	59
Table 62: FCC Power Level 5 GHz Per Antenna Port.....	60
Table 63: FCC Theory of Operation for WLAN.....	60
Table 64: FCC Theory of Operation for Bluetooth	61
Table 65: ISED Power Level 2.4 GHz WLAN Per Antenna Port.....	64
Table 66: ISED Power Level 2.4 GHz BT/BLE Per Antenna Port.....	64
Table 67: ISED Power Level 5 GHz Per Antenna Port.....	65
Table 68: ISED Theory of Operation for WLAN.....	65
Table 69: ISED Theory of Operation for Bluetooth.....	66
Table 70: Europe Power Level 2.4 GHz Per Antenna Port.....	66
Table 71: Europe Power Level 2.4 GHz BT/BLE Per Antenna Port.....	66
Table 72: Europe Power Level 5 GHz Per Antenna Port.....	67
Table 73: Europe Theory Operation for WLAN	67
Table 74: Europe Theory Operation for Bluetooth.....	67
Table 75: Taping Specifications	70

About This Document

Murata's Type 1XK is a small and high-performance module based on NXP's IW416 combo chipset, supporting IEEE 802.11a/b/g/n + Bluetooth 5.2 BR/EDR/LE. This datasheet describes Type 1XK module in detail.



Please be aware that an important notice concerning availability, standard warranty and use in critical applications of Murata products and disclaimers thereto appears at the end of this specification sheet.









Audience & Purpose

Intended audience includes any customer looking to integrate this module into their product. In particular, RF, hardware, software, and systems engineers.

Document Conventions

Table 1 describes the document conventions.

Table 1: Document Conventions

Conventions	Description
	Warning Note Indicates very important note. Users are strongly recommended to review.
	Info Note Intended for informational purposes. Users should review.
	Menu Reference Indicates menu navigation instructions. Example: Insert → Tables → Quick Tables → Save Selection to Gallery 
	External Hyperlink This symbol indicates a hyperlink to an external document or website. Example: Embedded Artists AB  Click on the text to open the external link.
	Internal Hyperlink This symbol indicates a hyperlink within the document. Example: Scope  Click on the text to open the link.
<code>Console input/output or code snippet</code>	Console I/O or Code Snippet This text Style denotes console input/output or a code snippet.
<code># Console I/O comment // Code snippet comment</code>	Console I/O or Code Snippet Comment This text Style denotes a console input/output or code snippet comment. <ul style="list-style-type: none"> • Console I/O comment (preceded by "#") is for informational purposes only and does not denote actual console input/output. • Code Snippet comment (preceded by "//") may exist in the original code.

1 Scope

This specification characterizes the IEEE 802.11a/b/g/n + Bluetooth 5.2 BR/EDR/LE combo module.

2 Key Features

- ◆ NXP IW416 inside
- ◆ Supports IEEE 802.11a/b/g/n specification: Dual band 2.4 GHz and 5 GHz
- ◆ SISO with 20 MHz and 40 MHz channels
- ◆ Up to MCS7 data rates (150 Mbps)
- ◆ Supports Bluetooth specification version 5.2
- ◆ For supported Bluetooth functions, refer to [Bluetooth SIG site](#) 
- ◆ WLAN interface: SDIO 3.0
- ◆ Bluetooth interface: HCI UART, PCM, and I2S
- ◆ Temperature Range: - 40 °C to 85 °C
- ◆ Dimensions: 9.1 x 8.3 x 1.3 mm
- ◆ Weight: 268.8 mg
- ◆ MSL: 3
- ◆ Surface-mount type
- ◆ RoHS compliant
- ◆ Total Fit: 71

3 Ordering Information

Table 2 provides the ordering information for Type 1XK module.

Table 2: Ordering Information

Ordering Part Number	Description
LBEE5CJ1XK-687	Module order
LBEE5CJ1XK-SMP	Sample module order (If module samples are not available through distribution, contact Murata referencing this part number)
EAR00385	Embedded Artists Type 1XK M.2 EVB (default EVB available through distribution)
LBEE5CJ1XK-EVB	Murata Type 1XK M.2 EVB (contact Murata as this is special order item)



LBEE5CJ1XK is used in regulatory certification test report.

4 Block Diagram

Figure 1 shows the block diagram of Type 1XK module.

Figure 1: Block Diagram

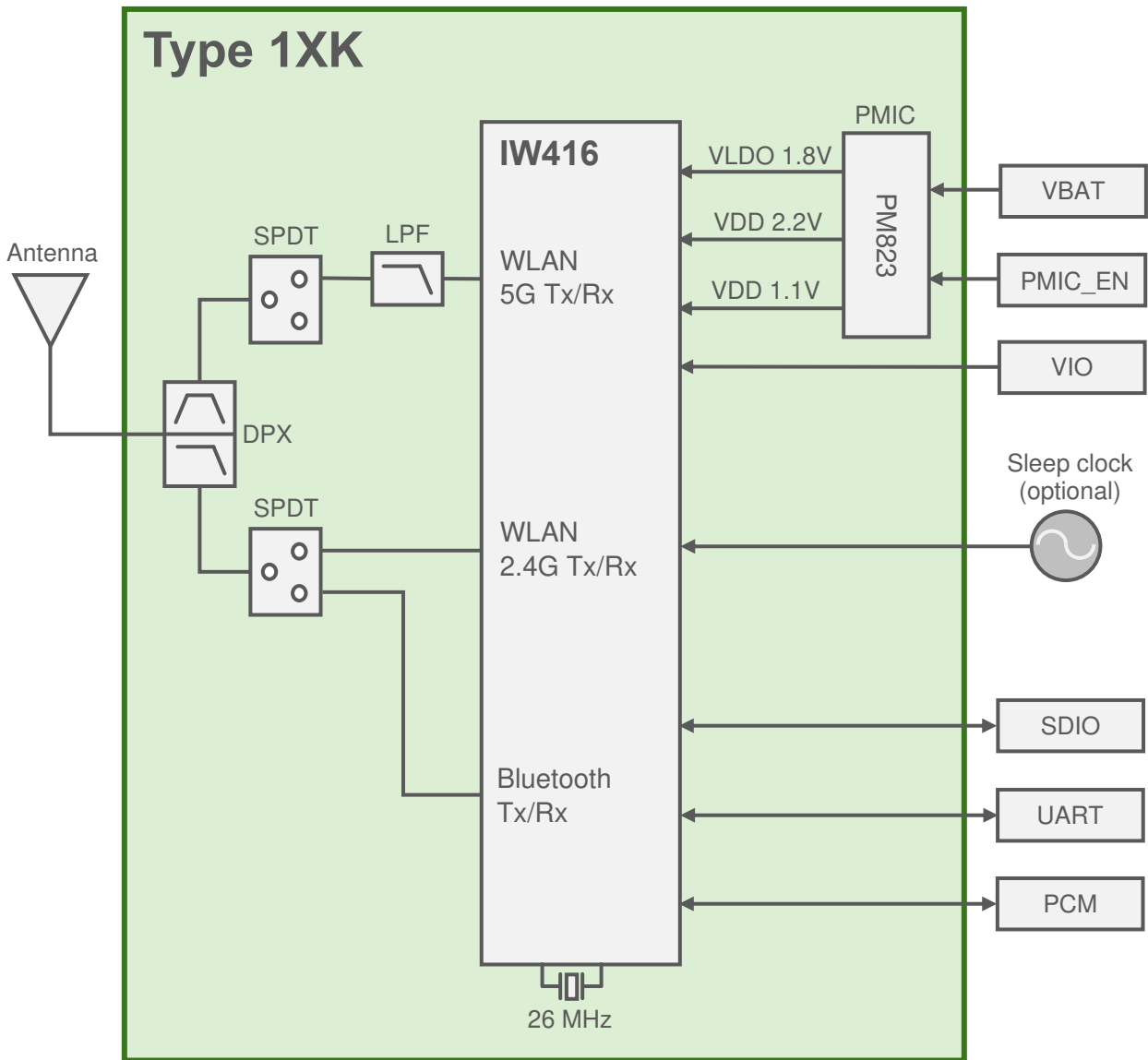

5 Certification Information

This section has information about radio and Bluetooth certification.

5.1 Radio Certification

Transmit output power setting is defined by “txpower_XX.bin” (XX is country code). The transmit power files are hosted at Murata GitHub for [Linux](#) and [FreeRTOS](#). **Table 3** shows the transmit power file required for each region.

Table 3: Transmit Power Limit Files

Country	ID	Country Code	Tx Power Limit File	
			Linux	FreeRTOS
USA (FCC)	VPYLB1XK	US	txpower_US.bin	wlan_txpwrlimit_cfg_murata_1XK_US.h
Canada (IC)	772C-LB1XK	CA	txpower_CA.bin	wlan_txpwrlimit_cfg_murata_1XK_CA.h
Europe	EN300328/301893, EN300440 conducted test report is prepared.	DE	txpower_EU.bin	wlan_txpwrlimit_cfg_murata_1XK_EU.h
Japan	Japanese type certification is prepared.  001-P01624	JP	txpower_JP.bin	wlan_txpwrlimit_cfg_murata_1XK_JP.h



Each country code is defined by Murata's db.txt file. Please ask your contact person from Murata.

5.2 Bluetooth Qualification

- QDID: 169159
- Set Bluetooth Tx Power to Class 1 by using [bt_power_config_1.sh](#).
- For supported Bluetooth functions, refer to [Bluetooth SIG site](#).

6 Dimensions, Markings and Terminal Configurations

This section has information on dimensions, markings, and terminal configurations for Type 1XK.

Figure 2: Dimensions, Markings and Terminal Configurations

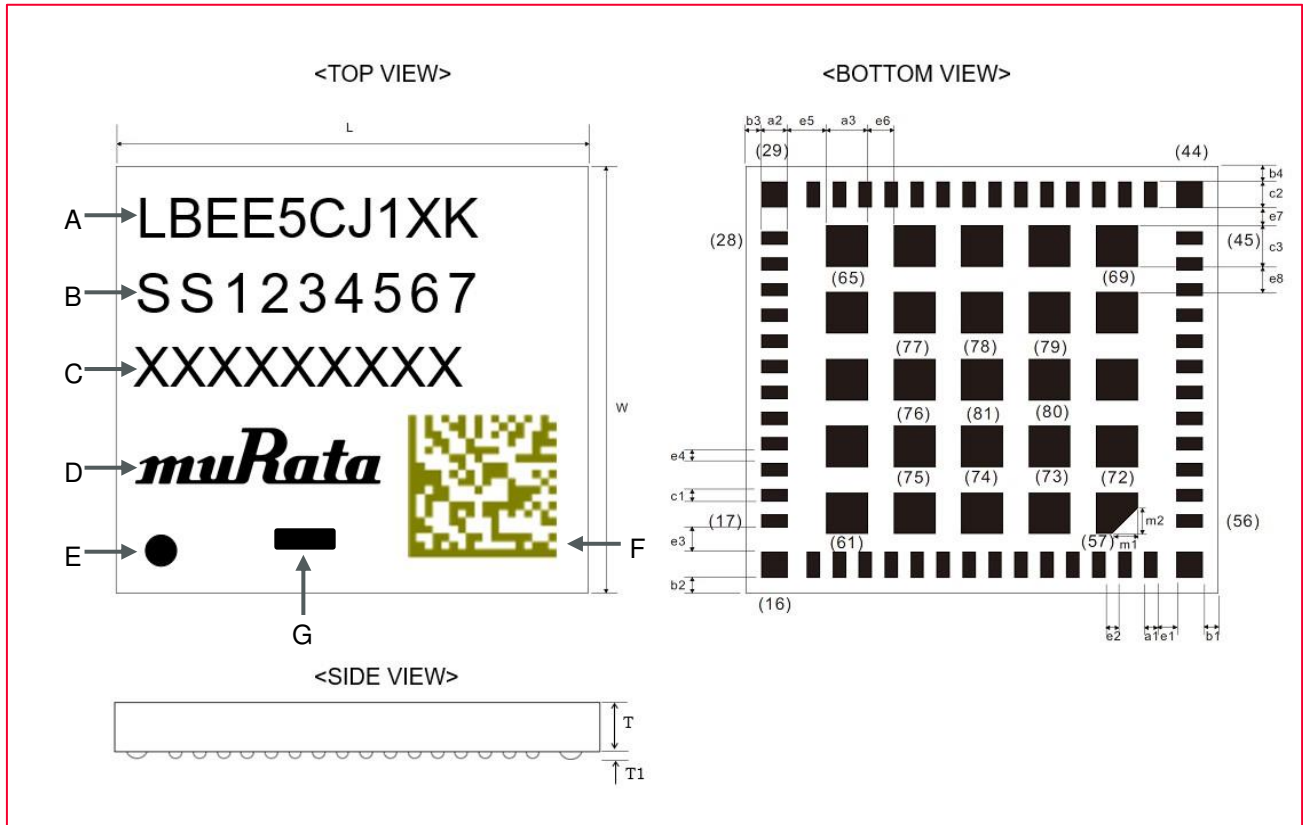

Table 4: Markings

Marking	Meaning
A	Module Type
B	Inspection Number
C	Serial Number
D	Murata Logo
E	Pin 1 Marking
F	2D code
G	Identification mark

Table 5: Dimensions

Marks	Dimensions	Marks	Dimensions	Marks	Dimensions	Marks	Dimensions
L	9.1 ± 0.2	W	8.3 ± 0.2	T	1.3 maximum	a1	0.25 ± 0.1
a2	0.5 ± 0.1	a3	0.8 ± 0.2	b1	0.3 ± 0.2	b2	0.3 ± 0.2
b3	0.3 ± 0.2	b4	0.3 ± 0.2	c1	0.25 ± 0.1	c2	0.5 ± 0.1
c3	0.8 ± 0.1	e1	0.375 ± 0.1	e2	0.25 ± 0.1	e3	0.475 ± 0.1
e4	0.25 ± 0.1	e5	0.75 ± 0.1	e6	0.5 ± 0.1	e7	0.35 ± 0.1
e8	0.5 ± 0.1	m1	0.5 ± 0.2	m2	0.5 ± 0.2	T1	0.045 typical



T dimension does not include height of solder bumps.
Unit of Dimensions are in mm.

Figure 3 shows the structure of Type 1XK.

Figure 3: Structure

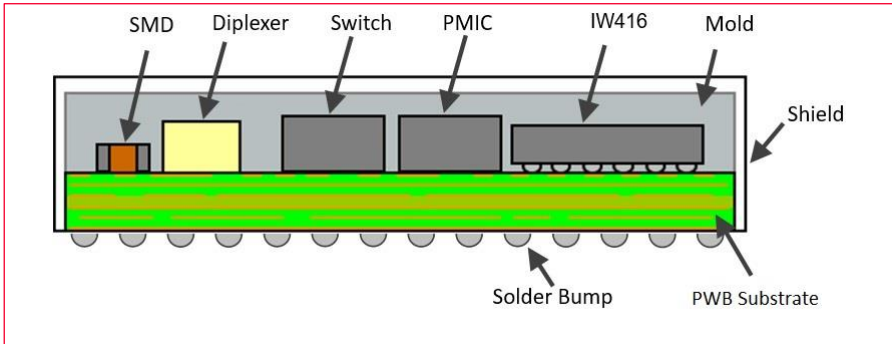

7 Module Pin Descriptions

This section has the pin descriptions of Type 1XK and pin assignments layout descriptions.

7.1 Pin Assignments

The pin assignment (Top View) layout is shown in **Figure 4**.

Figure 4: Pin Assignments Top View

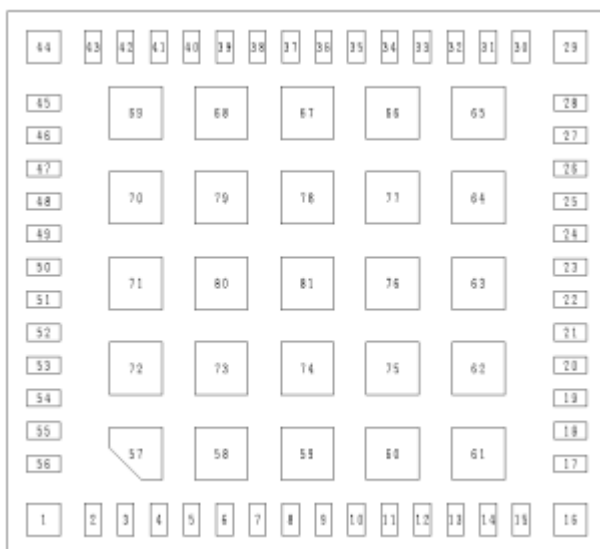

Table 6 illustrates the terminal configurations.

Table 6: Terminal Configurations

No.	Terminal Name	No.	Terminal Name	No.	Terminal Name
1	GND	20	GPIO(3) TDO	39	GND
2	VIO	21	GND	40	GND
3	SD_D2	22	VBAT	41	GND
4	SD_CLK	23	VBAT	42	RF_CNTL2_N
5	SD_D0	24	GND	43	RF_CNTL3_P
6	SD_CMD	25	GND	44	GND
7	GPIO(9) UART_RXD	26	GND	45	BT_ANT SHARED
8	GPIO(6)	27	GND	46	GND
9	GPIO(7)	28	GND	47	BT_ANT DEDICATED
10	NC	29	GND	48	GND
11	GPIO(4)	30	GND	49	GND
12	GPIO(1)	31	PMIC_EN	50	GND
13	GPIO(15) TMS	32	WCI_SOUT	51	GPIO(11) UART_RTS
14	GPIO(5)	33	WCI_SIN	52	GPIO(0)
15	GPIO(8) UART_CTS	34	GPIO(12)	53	GPIO(13)
16	GND	35	RF_CNTL1_P	54	GPIO(10) UART_TXD
17	GPIO(14) TCK	36	RF_CNTL0_N	55	SD_D3
18	GPIO(2) TDI	37	GND	56	SD_D1
19	SLP_CLK_IN	38	RF_ANT	57-81	GND

7.2 Pin Descriptions

Table 7 describes Type 1XK Pins.

Table 7: Pin Descriptions

No.	Pin Name	Type	Connection to IC Pin Name	Description
1	GND			Ground
2	VIO	P	VIO VIO_RF VIO_SD	Power supply
3	SD_D2	I	SD_DAT[2]	SDIO 4-bit mode: Data line Bit[2] or read wait (optional) SDIO 1-bit mode: Read wait (optional)
4	SD_CLK	I	SD_CLK	SDIO Clock input
5	SD_D0	I	SD_DAT[0]	SDIO 4-bit mode: Data line Bit[0] SDIO 1-bit mode: Data line
6	SD_CMD	I/O	SD_CMD	SDIO 4-bit mode: Command/response (input/output) SDIO 1-bit mode: Command line
7	GPIO(9) UART_RXD	I/O	GPIO[9]	GPIO mode: GPIO[9] (input/output) UART mode: UART_SIN (input)

No.	Pin Name	Type	Connection to IC Pin Name	Description
8	GPIO(6)	I/O	GPIO[6]	GPIO mode: GPIO[6] (input/output) PCM mode: PCM_CLK - PCM data clock (input if slave, output if master). I2S mode: I2S_BCLK - I2S bit clock (input if slave, output if master). PTA mode: EXT_PRI - External radio priority signal (input).
9	GPIO(7)	I/O	GPIO[7]	GPIO mode: GPIO[7] (input/output) PCM mode: PCM_SYNC - PCM frame sync (input if slave, output if master). I2S mode: I2S_LRCLK - I2S left-right clock (input if slave, output if master). PTA mode: EXT_REQ - Request from the external radio (input).
10	NC			NC *Floating terminal pad. Recommended grounding for mechanical strength.
11	GPIO(4)	I/O	GPIO[4]	GPIO mode: GPIO[4] (input/output) PCM mode: PCM_DOUT ¹ - PCM transmit signal (output). I2S mode: I2S_DOUT/I2S_DIN (depending on the configuration. If GPIO[5] is configured as I2S_DIN, then GPIO[4] is set as I2S_DOUT, and vice-versa). PTA mode: EXT_FREQ - External radio frequency signal (input). Out-of-band wake-up mode: IW416 Alternate Bluetooth to host wake-up signal (output) ²
12	GPIO(1)	I/O	GPIO[1]	GPIO mode: GPIO[1] (input/output) This pin is used as a configuration pin: CON[9] (input). PTA mode: EXT_STATE - External radio state signal (input). Out-of-band wake-up mode: IW416 Wi-Fi to host wake-up signal (output) Do not drive this signal during boot-up
13	GPIO(15) TMS	I/O	GPIO[15]	GPIO mode: GPIO[15] (input/output) Reset recovery mode: Independent software reset for Bluetooth subsystem (input).
14	GPIO(5)	I/O	GPIO[5]	GPIO mode: GPIO[5] (input/output) PCM mode: PCM_DIN ³ - PCM receive signal (input). I2S mode: I2S_DOUT/I2S_DIN - I2S transmit/receive signal (output/input) (depending on the configuration). PTA mode: EXT_GNT - External radio grant signal (output).
15	GPIO(8) UART_CTS	I/O	GPIO[8]	GPIO mode: GPIO[8] (input/output) This pin is used as a configuration pin: CON[7] (input) UART mode: UART_CTSn - UART clear-to-send input signal (input, active low). Do not drive this signal during boot-up
16	GND			Ground
17	GPIO(14) TCK	I/O	GPIO[14]	GPIO mode: GPIO[14] (input/output) Reset recovery mode: Independent software reset for Wi-Fi subsystem (input)
18	GPIO(2) TDI	I/O	GPIO[2]	GPIO mode: GPIO[2] (input/output) Power management mode: DVSC[0], Digital voltage scaling control (output)

¹ The function can be swapped with GPIO(5) using a software command without affecting the hardware connection.

² If PCM not used in application, GPIO(4) can be used as Bluetooth to host wake-up signal.

³ The function can be swapped with GPIO(4) using a software command without affecting the hardware connection.

No.	Pin Name	Type	Connection to IC Pin Name	Description
19	SLP_CLK_IN	I	SLP_CLK_IN	Sleep Clock Input (optional) Used for lower power operation in sleep mode. An external sleep clock of 32.768 kHz can be used for lowest current consumption in sleep mode. An external sleep clock is required if automatic reference clock frequency detection is used. If no external sleep clock is used, leave this pin floating (DNC).
20	GPIO(3) TDO	I/O	GPIO[3]	GPIO mode: GPIO[3] (input/output) Power management mode: DVSC[1], Digital voltage scaling control (output) PCM mode: PCM_MCLK (output) - PCM clock signal (output, optional). I2S mode: I2S_CCLK - I2S clock (output, optional).
21	GND			Ground
22	VBAT	P	PVIN(PMIC)	Power supply
23	VBAT	P	PVIN(PMIC)	Power supply
24	GND			Ground
25	GND			Ground
26	GND			Ground
27	GND			Ground
28	GND			Ground
29	GND			Ground
30	GND			Ground
31	PMIC_EN	I	EN(PMIC)	Enable build-in PMIC. Logic high enables internal regulators and internal hardware reset is de-asserted. Logic low disables regulators and internal hardware reset is asserted. Do not float this pin
32	WCI_SOUT			WCI-2_SOUT (output)
33	WCI_SIN			WCI-2_SIN (input)
34	GPIO(12)	I/O	GPIO[12]	GPIO mode: GPIO[12] (input/output) UART mode: UART_DSRn - UART data-set-ready (input) (active low). Host wake-up mode: Host to IW416 Bluetooth wake-up (input)
35	RF_CNTL1_P	O	RF_CNTL1_P	Reserved Set to 1.
36	RF_CNTL0_N	O	RF_CNTL0_N	RF Control 0—RF Control Output Low (output) This pin is used as a configuration pin: CON[0] (input).
37	GND			Ground
38	RF_ANT			
39	GND			Ground
40	GND			Ground
41	GND			Ground
42	RF_CNTL2_N	O	RF_CNTL2_N	Reserved Do not pull-up externally.
43	RF_CNTL3_P	O	RF_CNTL3_P	Reserved
44	GND			Ground
45	BT_ANT SHARED	I		BT in (Feedback)
46	GND			Ground
47	BT_ANT DEDICATED	O		BT output
48	GND			Ground

No.	Pin Name	Type	Connection to IC Pin Name	Description
49	GND			Ground
50	GND			Ground
51	GPIO(11) UART_RTS	I/O	GPIO[11]	GPIO mode: GPIO[11] (input/output) This pin is used as a configuration pin: CON[8] (input) UART mode: UART_RTSn - UART request-to-send (output) (active low). Do not drive this signal during boot-up
52	GPIO(0)	I/O	GPIO[0]	GPIO mode: GPIO[0] (input/output)
53	GPIO(13)	I/O	GPIO[13]	GPIO mode: GPIO[13] (input/output) UART mode: UART_DTRn - UART data-terminal-ready (output). Out-of-band wake-up mode: Host to IW416 Wi-Fi wake-up (input)
54	GPIO(10) UART_TXD	I/O	GPIO[10]	GPIO mode: GPIO[10] (input/output) UART mode: UART_SOUT - UART serial (output).
55	SD_D3	I	SD_DAT[3]	SDIO 4-bit mode: Data line Bit[3] SDIO 1-bit mode: Reserved
56	SD_D1	I	SD_DAT[1]	SDIO 4-bit mode: Data line Bit[1] SDIO 1-bit mode: Interrupt
57-81	GND			Ground



Not all GPIO pins can be used for Host-to-SoC wake-up signals.

7.3 Configuration Pins

Table 8 shows the pins used as configuration inputs to set parameters following a reset. The definitions of these pins change immediately after reset to their usual function.

Table 8: Configuration Pins

Configuration Bits	Pin Name	Configuration Function
CON[9]	GPIO[1]	Reserved Set to 111.
CON[8]	GPIO[11]	
CON[7]	GPIO[8]	
CON[1]	RF_CNTL2_N	Firmware Boot Options: No hardware impacts. Software reads and boots accordingly. See Table 9 . Note: Boot code needs to use this host boot strap status to decide the correct boot sequence.
CON[0]	RF_CNTL0_N	

Table 9: Configuration Functions for Wi-Fi and Bluetooth/LE

CON[1]	CON[0]	Wi-Fi	Bluetooth/LE
1	0	SDIO	UART
1	1	Reserved	Reserved



To set a configuration bit to 0, attach a 50 kΩ - 100 kΩ resistor from the pin to ground. No external circuitry is required to set a configuration bit to 1.

7.4 Pin States

Pin states information for **Table 10** include:

- After firmware is downloaded, the pads (GPIO, Serial interface, RF control) are programmed in functional mode per the functionality of the pins.
- For SDIO, once the command is received from the host, the pads are configured accordingly.
- Pull-up and pull-down are only effective when the pad is in input mode.
- The power-down state shown is the default configuration. Many pads have programmable power-down values, which can be set by firmware.
- Do not need any termination to the open pins in input mode that have an Internal pull-up/pull-down resistor (PU/PD). Do not need any termination to the open pins in output mode.

Table 10: I/O State Table

Pin Name	Supply	No Pad Power State	Reset State	HW State ⁴	PD State ⁵	PD Prog ⁶	Internal PU/PD	Int'l Pull Value[Ω] ⁷
GPIO0	VIO	tristate	output	output	drive low	yes	nominal PU	90K
GPIO1	VIO	tristate	input	input	tristate	yes	weak PU	800K
GPIO2	VIO	tristate	input	input	tristate	yes	weak PU	800K
GPIO3	VIO	tristate	input	input	tristate	yes	weak PU	800K
GPIO4	VIO	tristate	output	input	tristate	yes	nominal PU	90K
GPIO5	VIO	tristate	input	input	tristate	yes	weak PU	800K
GPIO6	VIO	tristate	input	input	tristate	yes	nominal PU	90K
GPIO7	VIO	tristate	input	input	tristate	yes	nominal PU	90K
GPIO8	VIO	tristate	input	input	drive low	yes	weak PU	800K
GPIO9	VIO	tristate	output	input	tristate	yes	nominal PU	90K
GPIO10	VIO	tristate	input	input	tristate	yes	nominal PU	90K
GPIO11	VIO	tristate	output	input	drive high	yes	weak PU	800K
GPIO12	VIO	tristate	input	input	tristate	yes	nominal PU	90K
GPIO13	VIO	tristate	input	input	drive high	yes	nominal PU	90K
SD_CLK	VIO_SD	tristate	input	input	tristate	no	nominal PD	90K
SD_CMD	VIO_SD	tristate	input	input	tristate	no	nominal PD	90K
SD_D0	VIO_SD	tristate	input	input	tristate	no	nominal PD	90K
SD_D1	VIO_SD	tristate	input	input	tristate	no	nominal PD	90K
SD_D2	VIO_SD	tristate	input	input	tristate	no	nominal PD	90K

⁴ Hardware default state after reset

⁵ Power-down state

⁶ Power-down state programmable

⁷ Calculate appropriate external pull values with internal pull value

Pin Name	Supply	No Pad Power State	Reset State	HW State ⁴	PD State ⁵	PD Prog ⁶	Internal PU/PD	Int'l Pull Value[Ω] ⁷
SD_D3	VIO_SD	tristate	input	input	tristate	no	nominal PD	90K
RF_CNTL0_N	VIO_RF	tristate	input	output	drive low	yes	weak PU	800K
RF_CNTL1_P	VIO_RF	tristate	input	output	drive high	yes	weak PU	800K
RF_CNTL2_N	VIO_RF	tristate	input	output	drive low	yes	weak PU	800K
RF_CNTL3_P	VIO_RF	tristate	input	output	drive high	yes	weak PU	800K
SLP_CLK_IN	AVDD18	tristate	input	input	tristate	no	nominal PU	90K
WCI-2_SIN	AVDD18	tristate	input	input	tristate	no	weak PU	800K
WCI-2_OUT	AVDD18	tristate	output	output	tristate	no	weak PU	800K

Table 11 shows the pin descriptions for Type 1XK module. **Figure 5** shows the SDIO pin diagram for Type 1XK module.

Table 11: SDIO Pin Descriptions

No.	Pin Name	(i) SD 4-bit Mode		(ii) SD 1-bit Mode	
4	SDIO_CLK	CLK	Clock	CLK	Clock
5	SDIO_D0	DATA0	Data line 0	DATA	Data line
45	SDIO_D1	DATA1	Data line 1	IRQ	Interrupt
3	SDIO_D2	DATA2	Data line 2	RW	Read wait (optional)
46	SDIO_D3	DATA3	Data line 3	NC	Reserved
6	SDIO_CMD	CMD	Command/response	CMD	Command line

Figure 5: SDIO Pins

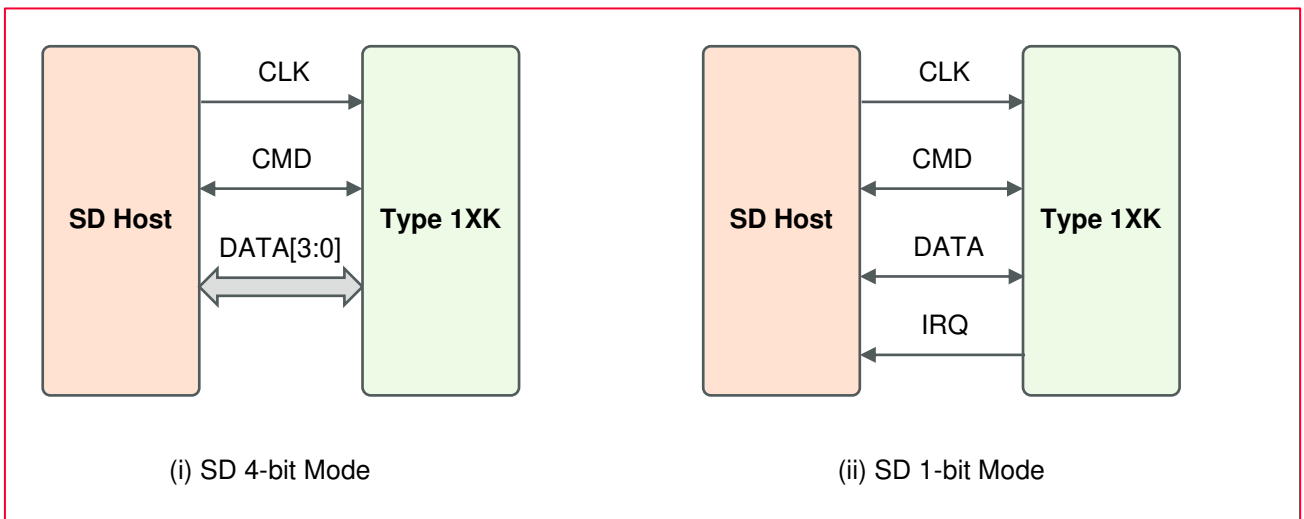

8 Absolute Maximum Ratings

The absolute maximum ratings are shown in **Table 12**.

Table 12: Absolute Maximum Ratings

Parameter		Minimum	Maximum	Unit
Storage Temperature		-40	85	°C
Supply Voltage	VBAT	-0.3	6.0	V
	VIO		4.0	V



Stresses in excess of the absolute ratings may cause permanent damage. Functional operation is not implied under these conditions. Exposure to absolute ratings for extended periods of time may adversely affect reliability. No damage assuming only one parameter is set at limit at a time with all other parameters are set within operating condition.

9 Operating Conditions

9.1 Operating Conditions

The operating conditions are shown in **Table 13**.

Table 13: Operating Conditions

Parameter		Minimum	Typical	Maximum	Unit
Operating Temperature	Ta	-40	25	+85	°C
	Tj			+125	°C
Supply Voltage	VBAT	2.7		5.5	V
	VIO	1.62	1.8	1.98	V
		2.97	3.3	3.47	V
IO Current	VIO		0.1	0.5	mA
Peak Current	VBAT		550	850	mA



- Operation beyond the recommended operating conditions is neither recommended nor guaranteed.
- Peak current of VBAT (RF portion) is happen during DPD calibration when the firmware is downloaded.

9.2 External Sleep Clock Requirements

Table 14 shows the external sleep clock requirements for Type 1XK module.

Table 14: External Sleep Clock Requirements

Symbol	Parameter	Minimum	Typical	Maximum	Unit
CLK	Clock frequency range/accuracy: <ul style="list-style-type: none"> • CMOS input clock signal type • ± 250 ppm (initial, aging, temperature) 		32.768		kHz

Symbol	Parameter	Minimum	Typical	Maximum	Unit
PN	Phase Noise Requirement (@ 100 kHz)		-125		dBc/Hz
Jc	Cycle jitter		1.5		ns (RMS)
SR	Slew rate limit (10-90%)			100	ns
DC	Duty cycle tolerance	20		80	%



Voltage input level = 1.8V

9.3 Digital I/O Requirements

Table 15 shows the digital I/O requirements for Type 1XK module.

Table 15: Digital I/O Requirements Parameters

Symbol	Parameter	Condition	Minimum	Typical	Maximum	Unit
V _{IH}	Input high voltage		0.7*V _{IO}		V _{IO} + 0.4	V
V _{IL}	Input low voltage		-0.4		0.3*V _{IO}	V
V _{HYS}	Input hysteresis		100			mV
V _{OH}	Output high voltage		V _{IO} -0.4			V
V _{OL}	Output low voltage				0.4	V

9.4 Package Thermal Conditions

The package thermal conditions as shown in Figure 6 are as below:

- R Ψ jt : 3.56 °C/W
- R Ψ jt = (Tj - Tt)/P



Tj: Junction temperature (°C), Tt: Top temperature (°C), P: Total Power Consumption (W)

Figure 6 show the package thermal conditions.

Figure 6: Package Thermal Conditions

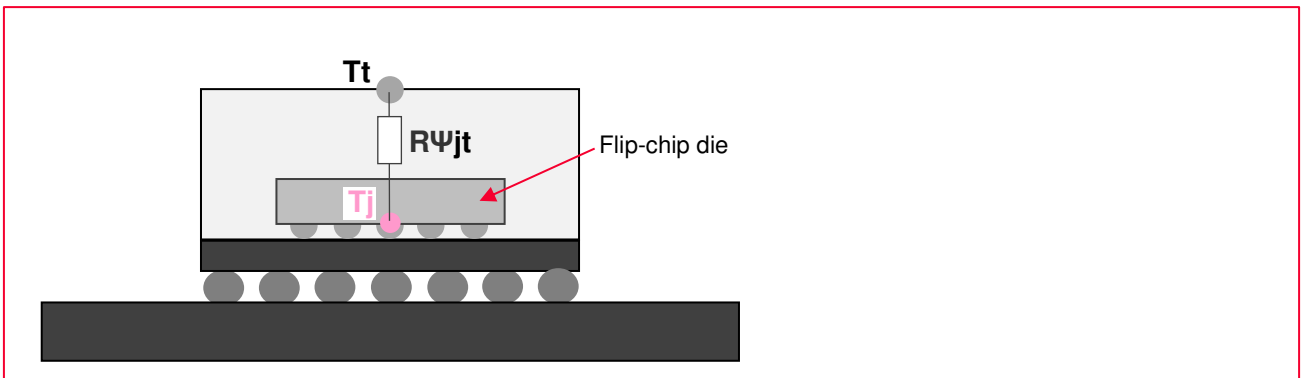

10 Power Sequence

This section describes the power-on and power-off sequences along with their parameters.

10.1 Power-On Sequence

- VBAT and VIO must be good (90%) at the same time or before assert PMIC_EN (= 0 to 1).
- Rump-up time of VIO must be < 100 ms

Figure 7: Power-On Sequence Graph

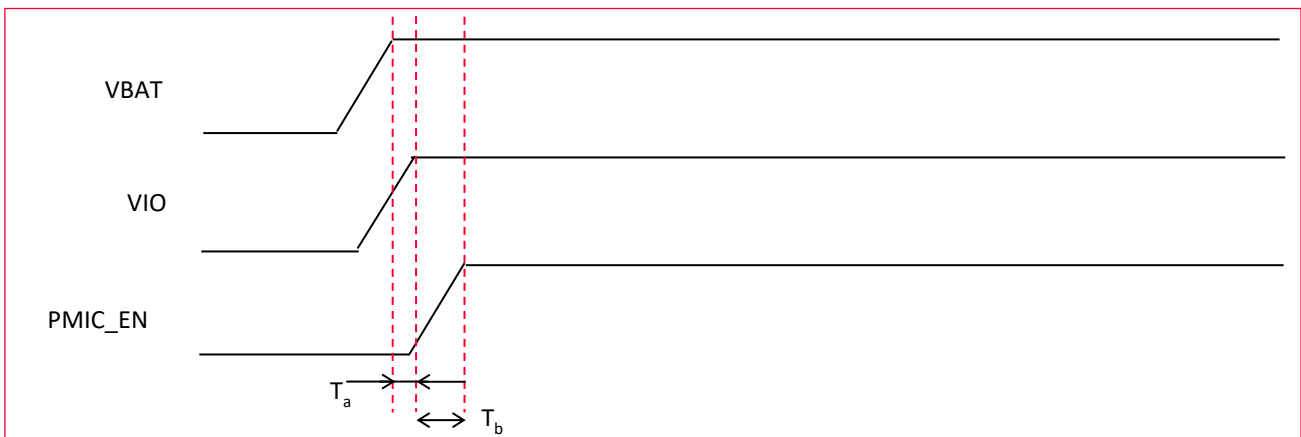

Table 16: Power-On Sequence Parameters

Symbol	Parameter	Minimum	Typical	Maximum	Unit
T_a	VBAT to VIO time	0			ms
T_b	VIO to PMIC_EN time	0			ms

10.2 Power-Off Sequence

10.2.1 Power-Off Sequence

- VBAT and VIO must be down at the same time or before de-assert PMIC_EN (= 1 to 0).
- Rump-down time of VIO must be < 100 ms

Figure 8: Power-Off Sequence Graph

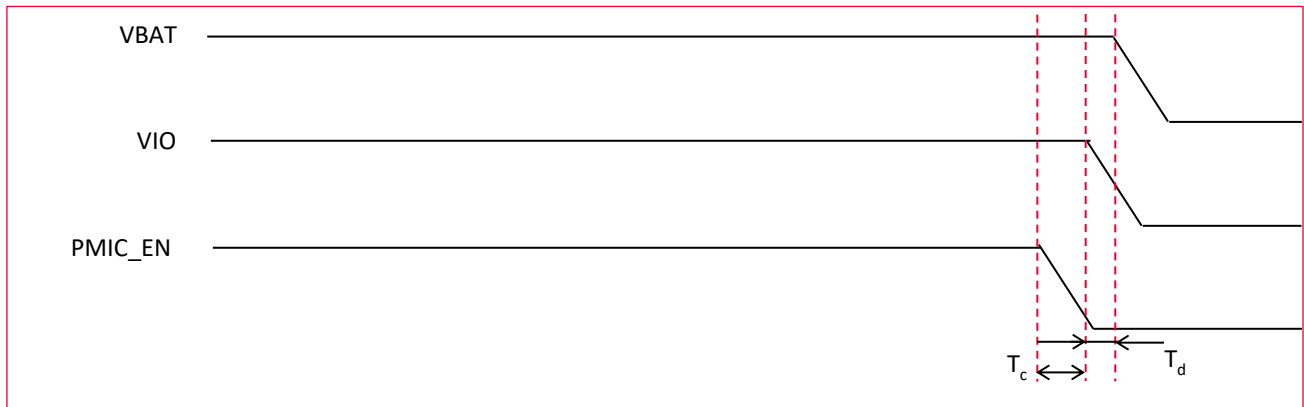

Table 17: Power-Off Sequence Parameters

Symbol	Parameter	Minimum	Typical	Maximum	Unit
T_c	PMIC_EN to VIO time	0			ms
T_d	VIO to VBAT time	0			ms

10.2.2 Host Power Off Pin (PMIC_EN) Usage

PMIC_EN must be asserted a minimum of 100 ms.

Figure 9: Host Power Off Pin (PMIC_EN) Usage Graph

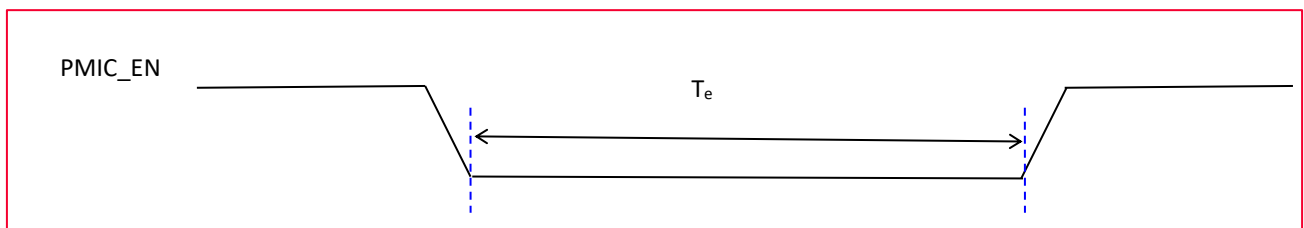

Table 18: Host Power Off Pin (PMIC_EN) Usage Parameters

Symbol	Parameter	Minimum	Typical	Maximum	Unit
T_e	PMIC_EN deassert to assert	100			ms

11 Interface Timing

This section describes the interface timing, its speed modes, related parameters, and graphs.

11.1 SDIO Timing

This section describes the SDIO timings for different modes.

11.1.1 Default Speed Mode

The default speed mode is shown in **Figure 10**.

Figure 10: SDIO Protocol Timing Diagram - Default Speed Mode

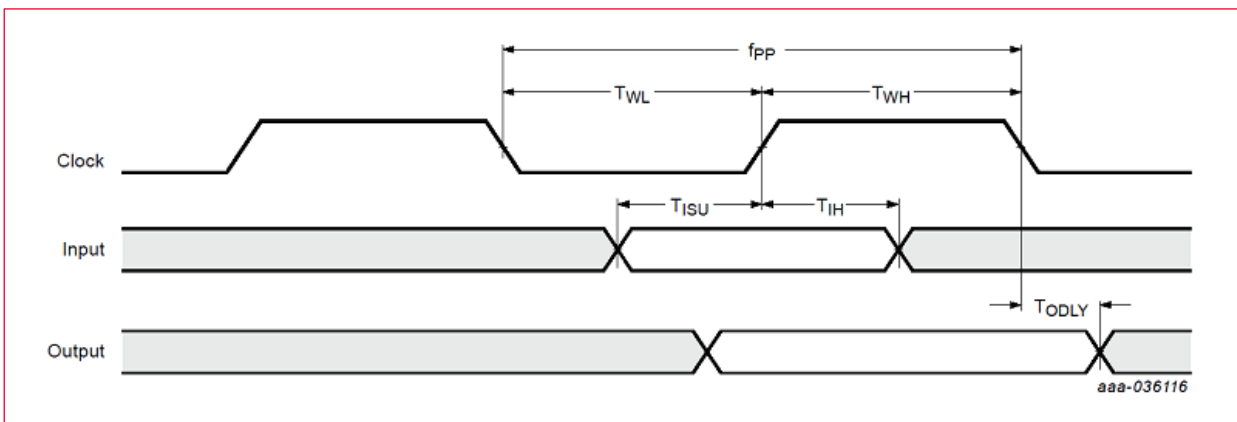

11.1.2 High Speed Mode

The high speed mode is shown in **Figure 11**.

Figure 11: SDIO Protocol Timing Diagram - High Speed Mode

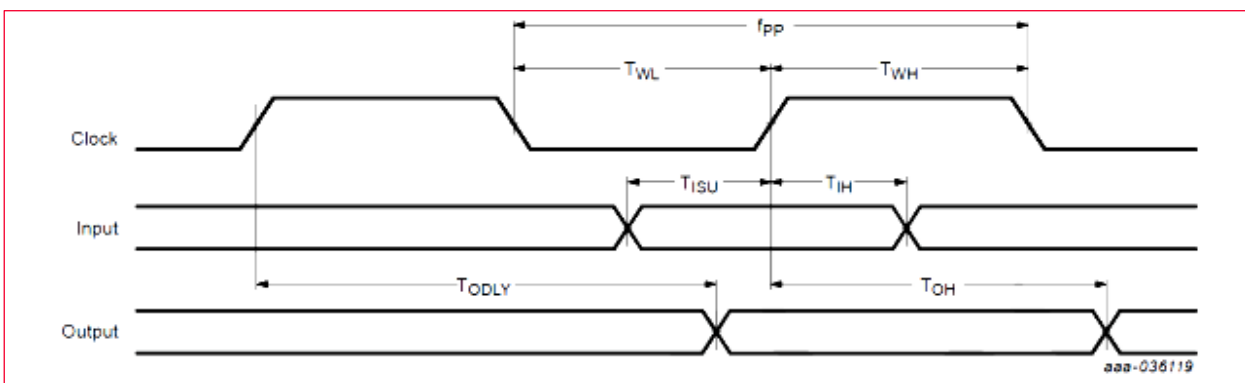

Table 19: SDIO Timing Data - High Speed Mode

Symbol	Parameter	Condition	Minimum	Typical	Maximum	Unit
f_{PP}	Clock frequency	Normal	0		25	MHz
		High speed	0		50	MHz
T_{WL}	Clock low time	Normal	10			ns
		High speed	7			ns

Symbol	Parameter	Condition	Minimum	Typical	Maximum	Unit
T _{WH}	Clock high time	Normal	10			ns
		High speed	7			ns
T _{ISU}	Input Setup Time	Normal	5			ns
		High speed	6			ns
T _{IH}	Input hold Time	Normal	5			ns
		High speed	2			ns
T _{ODLY}	Output delay time	Normal			14	ns
	CL ≤ 40 pF (1 card)	High speed			14	ns
T _{OH}	Output hold time	High speed	2.5			ns



For SDIO 2.0 running at 25 MHz and 50 MHz clock frequency, VIO_SD must be 3.3V.

11.1.3 SDR12, SDR25, and SDR50 Modes up to 100 MHz (1.8 V)

Figure 12 shows the SDIO protocol timing diagram for SDR12, SDR25, SDR50 modes (up to 100 MHz & 1.8 V).

Figure 12: SDIO Protocol Timing Diagram - SDR12, SDR25, and SDR50 Modes

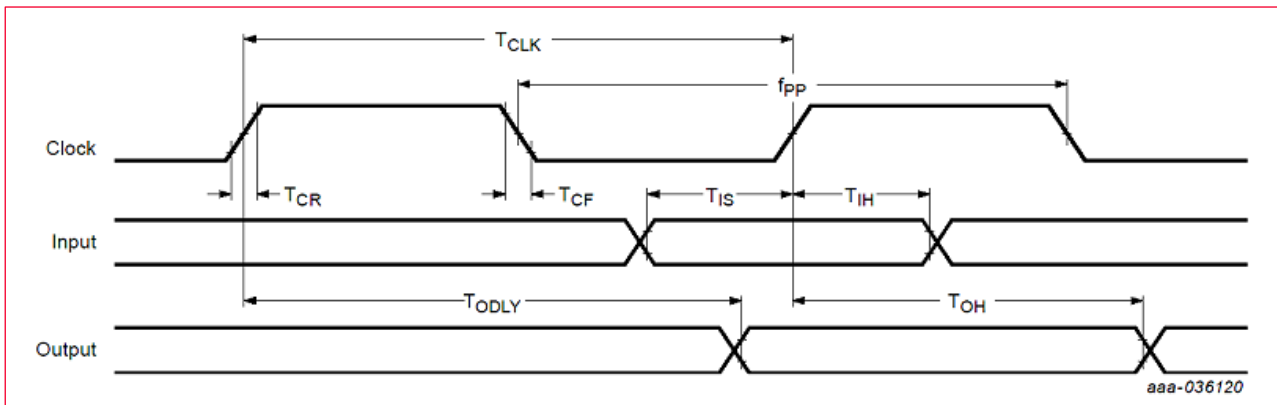

Table 20: SDIO Protocol Timing Parameters - SDR12, SDR25, and SDR50 Modes

Symbol	Parameter	Condition	Minimum	Typical	Maximum	Unit
f _{PP}	Clock frequency	SDR12/25/50	25		100	MHz
T _{IS}	Input setup time	SDR12/25/50	3			ns
T _{IH}	Input hold time	SDR12/25/50	0.8			ns
T _{CLK}	Clock time	SDR12/25/50	10		40	ns
T _{CR} , T _{CF}	Rise time, fall time T _{CR} , T _{CF} < 2 ns (maximum) at 100 MHz C _{CARD} = 10 pF	SDR12/25/50			0.2 * T _{CLK}	ns
T _{ODLY}	Output delay time C _L ≤ 30 pF	SDR12/25/50			7.5	ns
T _{OH}	Output hold time C _L = 15 pF	SDR12/25/50	1.5			ns

11.1.4 DDR50 Mode at 50 MHz (1.8V)

Figure 13 shows the SDIO CMD timing diagram for DDR50 mode (up to 50 MHz and 1.8V).

Figure 13: SDIO CMD Timing Diagram - DDR50 Mode

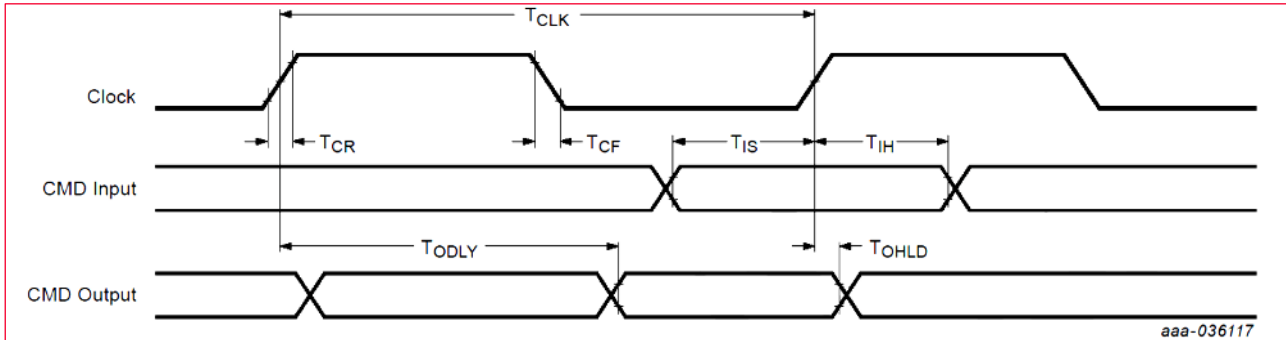

In DDR50 mode, DAT[3:0] lines are sampled on both edges of the clock (not applicable for CMD line).

Figure 14 shows the SDIO DATA timing diagram for DDR50 mode.

Figure 14: SDIO DATA Timing Diagram - DDR50 Mode

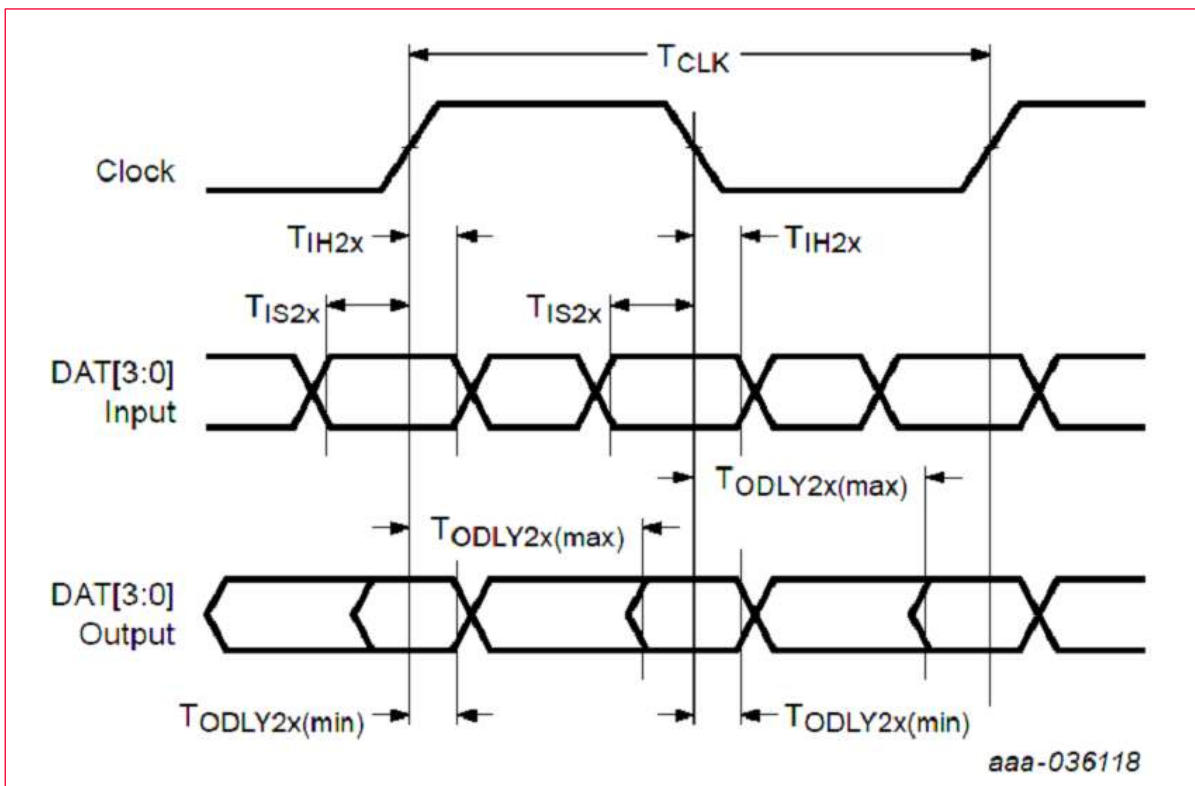

Table 21: SDIO Protocol Timing Parameters - DDR50 Mode

Symbol	Parameter	Condition	Minimum	Typical	Maximum	Unit
Clock						
T _{CLK}	Clock time 50 MHz (maximum) between rising edges	DDR50	20			ns
T _{CR} , T _{CF}	Rise time, fall time T _{CR} , T _{CF} < 4.00 ns(maximum) at 50 MHz C _{CARD} =10 pF	DDR50			0.2*T _{CLK}	ns
Clock Duty		DDR50	45		55	%
CMD Input (referenced to clock rising edge)						
T _{IS}	Input setup time C _{CARD} ≤ 10 pF (1 card)	DDR50	6			ns
T _{IH}	Input hold time C _{CARD} ≤ 10 pF (1 card)	DDR50	0.8			ns
CMD Output (referenced to clock rising edge)						
T _{ODLY}	Output delay time during data transfer mode C _L ≤ 30 pF (1 card)	DDR50			13.7	ns
T _{OHL D}	Output hold time C _L ≥ 15 pF (1 card)	DDR50	1.5			ns
DAT [3:0] Input (referenced to clock rising and falling edges)						
T _{IS2x}	Input setup time C _{CARD} ≤ 10 pF (1 card)	DDR50	3			ns
T _{IH2x}	Input hold time C _{CARD} ≤ 10 pF (1 card)	DDR50	0.8			ns
DAT [3:0] Output (referenced to clock rising and falling edges)						
T _{ODLY2x (max)}	Output delay time during data transfer mode C _L ≤ 25 pF (1 card)	DDR50			7.0	ns
T _{ODLY2x (min)}	Output hold time C _L ≥ 15 pF (1 card)	DDR50	1.5			ns

11.2 UART Timing (Default Mode)

Figure 15 show the UART timing default mode. The default baud rate is 115200 bps. Baud rate is configurable by the host stack.

Figure 15: UART Timing Diagram

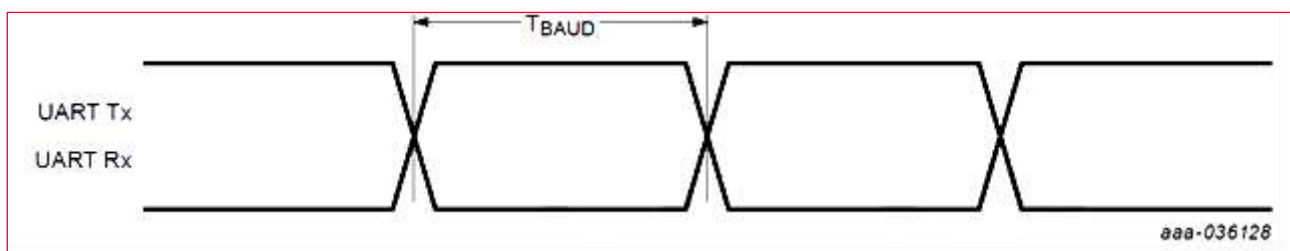

Table 22: UART Timing Data

Symbol	Parameter	Condition	Minimum	Typical	Maximum	Unit
TBAUD	Baud rate	38.4 MHz	250			ns



The acceptable deviation from the UART Rx target baud rate is $\pm 3\%$.

11.3 Bluetooth PCM Timing

This section describes the master and slave modes for Bluetooth PCM and data signals along with their parameters.

11.3.1 Master Mode

Figure 16 and **Figure 17** shows the timing diagram of master mode for Bluetooth data and PCM_SYNC signals.

Figure 16: Bluetooth Data Signal - Master Mode

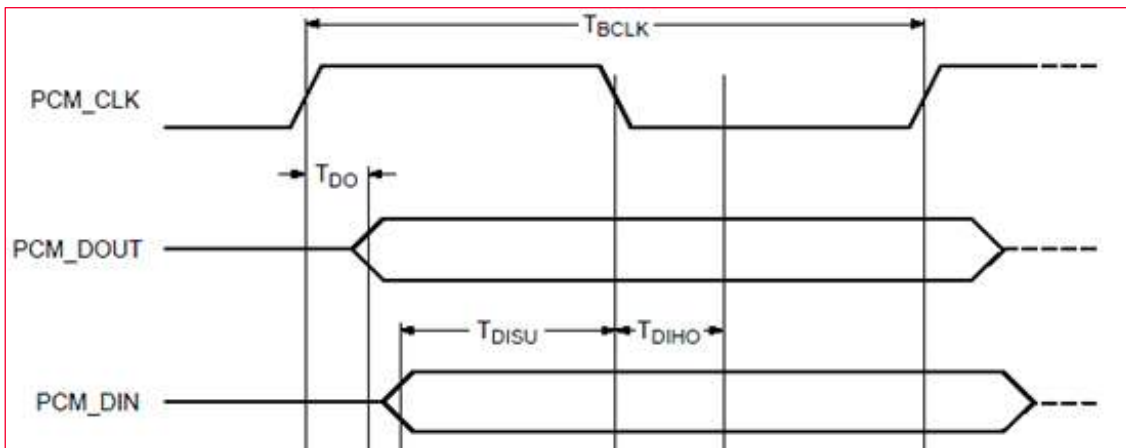

Figure 17: Bluetooth PCM_SYNC Signal - Master Mode

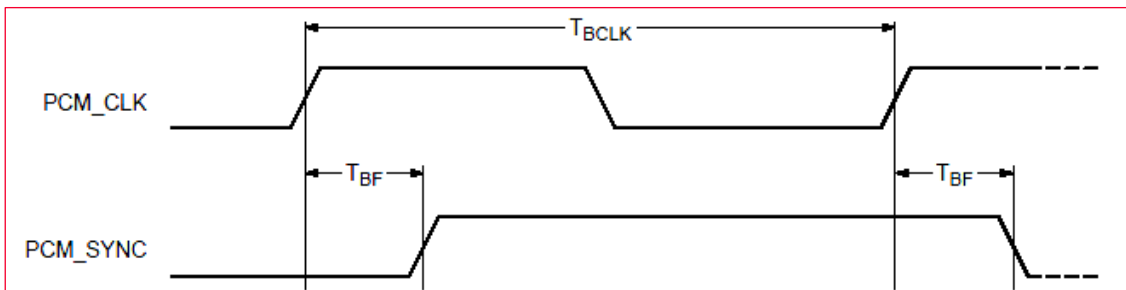

Table 23 lists information about the data and PCM_SYNC signals in master mode.

Table 23: Symbol Definition for Data Signal & PCM_SYNC Signal - Master Mode

Symbol	Parameter	Condition	Minimum	Typical	Maximum	Unit
F_{BCLK}	Bit clock frequency			2/2.048		MHz
Duty Cycle $_{BCLK}$	Bit clock duty cycle		0.4	0.5	0.6	
$T_{BCLK\ rise/fall}$	PCM_CLK rise/fall time			3		ns
T_{DO}	Delay from PCM_CLK rising edge to PCM_DOUT rising edge				15	ns
T_{DISU}	Setup time for PCM_DIN before PCM_CLK falling edge		20			ns
T_{DIHO}	Hold time for PCM_DIN after PCM_CLK falling edge		15			ns
T_{BF}	Delay from PCM_CLK rising edge to PCM_SYNC rising edge				15	ns

11.3.2 Slave Mode

Figure 18 and **Figure 19** shows the timing diagram of slave mode for data and PCM_SYNC signals. **Table 24** lists information about the data and PCM_SYNC signals in slave mode.

Figure 18: Bluetooth Data Signal - Slave Mode

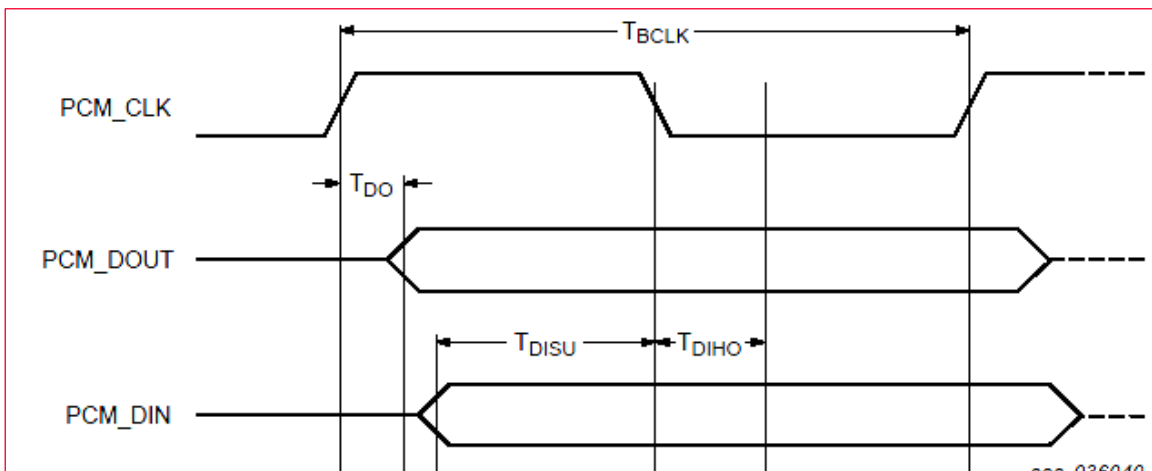

Figure 19: Bluetooth PCM_Sync Signal - Slave Mode

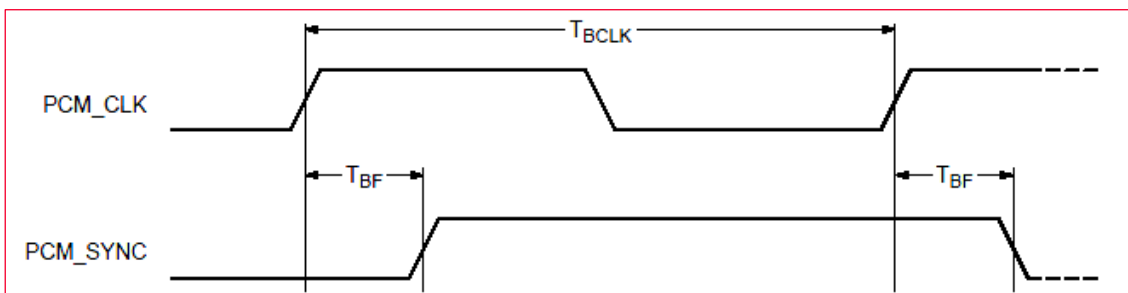

Table 24: Symbol Definition for Data Signal & PCM_SYNC Signal - Slave Mode

Symbol	Parameter	Condition	Minimum	Typical	Maximum	Unit
F _{BCLK}	Bit clock frequency			2/2.048		MHz
Duty Cycle _{BCLK}	Bit clock duty cycle		0.4	0.5	0.6	
T _{BCLK rise/fall}	PCM_CLK rise/fall time			3		ns
T _{DO}	Delay from PCM_CLK rising edge to PCM_DOUT rising edge				30	ns
T _{DISU}	Setup time for PCM_DIN before PCM_CLK falling edge		15			ns
T _{DIHO}	Hold time for PCM_DIN after PCM_CLK falling edge		10			ns
T _{BFSU}	Setup time for PCM_SYNC before PCM_CLK falling edge		15			ns
T _{BFHO}	Hold time for PCM_SYNC after PCM_CLK falling edge		10			ns

12 DC/RF Characteristics

All DC/RF characteristics are defined by following files as shown with file names in **Table 25**. **Figure 20** shows the burst current definition for Type 1XK module.

Table 25: DC/RF Characteristics and Files

Characteristics	Filenames
WLAN Tx Power	txpower_US.bin, txpower_CA.bin, txpower_EU.bin, txpower_JP.bin
WLAN Regulatory Limit	db.txt
Energy Detect	ed_mac.bin
Bluetooth Power	bt_power_config_1.sh (Class 1)

Figure 20: Burst Current Definition

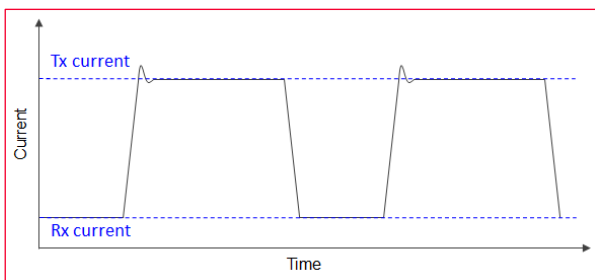

12.1 DC/RF Characteristics for IEEE 802.11b - 2.4 GHz

Table 26: Characteristics Values for IEEE 802.11b - 2.4 GHz

Items	Contents
Specification	IEEE 802.11b
Mode	DSSS / CCK
Channel Frequency	2412 - 2472 MHz
Data Rate	1, 2, 5.5, 11 Mbps

12.1.1 High-Rate Condition for IEEE 802.11b - 2.4 GHz

Conditions: 25 °C, VBAT = 3.3V, VIO = 1.8V, Output power setting = 17 dBm at module pad, 11 Mbps mode

Table 27: High-Rate Condition for IEEE 802.11b - 2.4 GHz

Items	Contents			
DC Characteristics	Minimum	Typical	Maximum	Unit
DC Current				
• Tx mode		400	560	mA
• Rx mode		50	65	mA
Tx Characteristics	Minimum	Typical	Maximum	Unit
Output Power	15.0	17.0	19.0	dBm
Spectrum Mask Margin				
• 1st side lobes	0			dB
• 2nd side lobes	0			dB
Power-on/off ramp			2.0	μs
RF Carrier Suppression	15			dB
Modulation Accuracy			35	%
Frequency Tolerance	-20		20	ppm
Spurious Emissions				
• 30 - 47 MHz (BW = 100 kHz)			-36	dBm
• 47 - 74 MHz (BW = 100 kHz)			-54	dBm
• 74 - 87.5 MHz (BW = 100 kHz)			-36	dBm
• 87.5 - 118 MHz (BW = 100 kHz)			-54	dBm
• 118 - 174 MHz (BW = 100 kHz)			-36	dBm
• 174 - 230 MHz (BW = 100 kHz)			-54	dBm
• 230 - 470 MHz (BW = 100 kHz)			-36	dBm
• 470 - 862 MHz (BW = 100 kHz)			-54	dBm
• 862 - 1000 MHz (BW = 100 kHz)			-36	dBm
• 1000 - 12750 MHz (BW = 1 MHz)			-30	dBm
Rx Characteristics	Minimum	Typical	Maximum	Unit
Minimum Input Level (FER ≤ 8%)			-76	dBm
Maximum Input Level (FER ≤ 8%)	-10			dBm
Adjacent Channel Rejection (FER < 8%)	35			dB

12.1.2 Low-Rate Condition for IEEE 802.11b - 2.4 GHz

Conditions: 25 °C, VBAT = 3.3V, VIO = 1.8V, Output power setting = 17 dBm at module pad, 1 Mbps mode

Table 28: Low-Rate Condition for IEEE 802.11b - 2.4 GHz

Items	Contents			
	Minimum	Typical	Maximum	Unit
DC Characteristics				
DC Current				
• Tx mode		390	550	mA
• Rx mode		50	65	mA
Tx Characteristics				
Output Power	15.0	17.0	19.0	dBm
Spectrum Mask Margin				
• 1st side lobes	0			dB
• 2nd side lobes	0			dB
Power-on/off ramp			2.0	μs
RF Carrier Suppression	15			dB
Modulation Accuracy			35	%
Frequency Tolerance	-20		20	ppm
Spurious Emissions				
• 30 - 47 MHz (BW = 100 kHz)			-36	dBm
• 47 - 74 MHz (BW = 100 kHz)			-54	dBm
• 74 - 87.5 MHz (BW = 100 kHz)			-36	dBm
• 87.5 - 118 MHz (BW = 100 kHz)			-54	dBm
• 118 - 174 MHz (BW = 100 kHz)			-36	dBm
• 174 - 230 MHz (BW = 100 kHz)			-54	dBm
• 230 - 470 MHz (BW = 100 kHz)			-36	dBm
• 470 - 862 MHz (BW = 100 kHz)			-54	dBm
• 862 - 1000 MHz (BW = 100 kHz)			-36	dBm
• 1000 - 12750 MHz (BW = 1 MHz)			-30	dBm
Rx Characteristics				
Minimum Input Level (FER ≤ 8%)			-80	dBm
Maximum Input Level (FER ≤ 8%)	-4			dBm
Adjacent Channel Rejection (FER < 8%)	35			dB

12.2 DC/RF Characteristics for IEEE 802.11g - 2.4 GHz

Table 29: Characteristics Values for IEEE 802.11g - 2.4 GHz

Items	Contents
Specification	IEEE 802.11g
Mode	OFDM
Channel Frequency	2412 - 2472 MHz
Data Rate	6, 9, 12, 18, 24, 36, 48, 54 Mbps

12.2.1 High-Rate Condition for IEEE 802.11g - 2.4 GHz

Conditions: 25 °C, VBAT = 3.3V, VIO = 1.8V, Output power setting = 16 dBm at module pad, 54 Mbps mode

Table 30: High-Rate Condition for IEEE 802.11g - 2.4 GHz

Items	Contents			
DC Characteristics	Minimum	Typical	Maximum	Unit
DC Current				
• Tx mode		344	480	mA
• Rx mode		50	65	mA
Tx Characteristics	Minimum	Typical	Maximum	Unit
Output Power	14.0	16.0	18.0	dBm
Spectrum Mask Margin				
• 9 MHz to 11 MHz (0 ~ -20 dBr)	0			dB
• 11 MHz to 20 MHz (-20 ~ -28 dBr)	0			dB
• 20 MHz to 30 MHz (-28 ~ -40 dBr)	0			dB
• 30 MHz to 33 MHz (-40 dBr)	0			dB
Constellation Error (EVM)			-25	dB
Frequency Tolerance	-20		20	ppm
Spurious Emissions				
• 30 - 47 MHz (BW = 100 kHz)			-36	dBm
• 47 - 74 MHz (BW = 100 kHz)			-54	dBm
• 74 - 87.5 MHz (BW = 100 kHz)			-36	dBm
• 87.5 - 118 MHz (BW = 100 kHz)			-54	dBm
• 118 - 174 MHz (BW = 100 kHz)			-36	dBm
• 174 - 230 MHz (BW = 100 kHz)			-54	dBm
• 230 - 470 MHz (BW = 100 kHz)			-36	dBm
• 470 - 862 MHz (BW = 100 kHz)			-54	dBm
• 862 - 1000 MHz (BW = 100 kHz)			-36	dBm
• 1000 - 12750 MHz (BW = 1 MHz)			-30	dBm
Rx Characteristics	Minimum	Typical	Maximum	Unit
Minimum Input Level (PER < 10%)			-65	dBm
Maximum Input Level (PER < 10%)	-20			dBm
Adjacent Channel Rejection (PER < 10%)	-1			dB

12.2.2 Low-Rate Condition for IEEE 802.11g - 2.4 GHz

Conditions: 25 °C, VBAT = 3.3V, VIO = 1.8V, Output power setting = 17 dBm at module pad, 6 Mbps mode

Table 31: Low-Rate Condition for IEEE 802.11g - 2.4 GHz

Items	Contents			
DC Characteristics	Minimum	Typical	Maximum	Unit
DC Current				
• Tx mode		376	530	mA
• Rx mode		50	65	mA
Tx Characteristics	Minimum	Typical	Maximum	Unit
Output Power	15.0	17.0	19.0	dBm
Spectrum Mask Margin				
• 9 MHz to 11 MHz (0 ~ -20 dBr)	0			dB
• 11 MHz to 20 MHz (-20 ~ -28 dBr)	0			dB
• 20 MHz to 30 MHz (-28 ~ -40 dBr)	0			dB
• 30 MHz to 33 MHz (-40 dBr)	0			dB
Constellation Error (EVM)			-5	dB
Frequency Tolerance	-20		20	ppm
Spurious Emissions				
• 30 - 47 MHz (BW = 100 kHz)			-36	dBm
• 47 - 74 MHz (BW = 100 kHz)			-54	dBm
• 74 - 87.5 MHz (BW = 100 kHz)			-36	dBm
• 87.5 - 118 MHz (BW = 100 kHz)			-54	dBm
• 118 - 174 MHz (BW = 100 kHz)			-36	dBm
• 174 - 230 MHz (BW = 100 kHz)			-54	dBm
• 230 - 470 MHz (BW = 100 kHz)			-36	dBm
• 470 - 862 MHz (BW = 100 kHz)			-54	dBm
• 862 - 1000 MHz (BW = 100 kHz)			-36	dBm
• 1000 - 12750 MHz (BW = 1 MHz)			-30	dBm
Rx Characteristics	Minimum	Typical	Maximum	Unit
Minimum Input Level (PER < 10%)			-82	dBm
Maximum Input Level (PER < 10%)	-20			dBm
Adjacent Channel Rejection (PER < 10%)	-1			dB

12.3 DC/RF Characteristics for IEEE 802.11n (HT20) - 2.4 GHz

Table 32: Characteristics Values for IEEE 802.11n (HT20) - 2.4 GHz

Items	Contents
Specification	IEEE 802.11n 20 MHz BW
Mode	OFDM
Channel Frequency	2412 - 2472 MHz
Data Rate	MCS0-MCS7

12.3.1 High-Rate Condition for IEEE 802.11n (HT20) - 2.4 GHz

Conditions: 25 °C, VBAT = 3.3V, VIO = 1.8V, Output power setting = 15 dBm at module pad, MCS7 mode

Table 33: High-Rate Condition for IEEE 802.11n (HT20) - 2.4 GHz

Items	Contents			
DC Characteristics	Minimum	Typical	Maximum	Unit
DC Current				
• Tx mode		320	450	mA
• Rx mode		50	65	mA
Tx Characteristics	Minimum	Typical	Maximum	Unit
Output Power	13.0	15.0	17.0	dBm
Spectrum Mask Margin				
• 9 MHz to 11 MHz (0 ~ -20 dBr)	0			dB
• 11 MHz to 20 MHz (-20 ~ -28 dBr)	0			dB
• 20 MHz to 30 MHz (-28 ~ -45 dBr)	0			dB
• 30 MHz to 33 MHz (-45 dBr)	0			dB
Constellation Error (EVM) (measured at enhanced mode)			-27	dB
Frequency Tolerance	-20		20	ppm
Spurious Emissions				
• 30 - 47 MHz (BW = 100 kHz)			-36	dBm
• 47 - 74 MHz (BW = 100 kHz)			-54	dBm
• 74 - 87.5 MHz (BW = 100 kHz)			-36	dBm
• 87.5 - 118 MHz (BW = 100 kHz)			-54	dBm
• 118 - 174 MHz (BW = 100 kHz)			-36	dBm
• 174 - 230 MHz (BW = 100 kHz)			-54	dBm
• 230 - 470 MHz (BW = 100 kHz)			-36	dBm
• 470 - 862 MHz (BW = 100 kHz)			-54	dBm
• 862 - 1000 MHz (BW = 100 kHz)			-36	dBm
• 1000 - 12750 MHz (BW = 1 MHz)			-30	dBm
Rx Characteristics	Minimum	Typical	Maximum	Unit
Minimum Input Level (PER ≤ 10%)			-64	dBm
Maximum Input Level (PER < 10%)	-20			dBm
Adjacent Channel Rejection (PER ≤ 10%)	-2			dB

12.3.2 Low-Rate Condition for IEEE 802.11n (HT20) - 2.4 GHz

Conditions: 25 °C, VBAT = 3.3V, VIO = 1.8V, Output power setting = 16 dBm at module pad, MCS0 mode

Table 34: Low-Rate Condition for IEEE 802.11n (HT20) - 2.4 GHz

Items	Contents			
DC Characteristics	Minimum	Typical	Maximum	Unit
DC Current				
• Tx mode		351	490	mA
• Rx mode		50	65	mA
Tx Characteristics	Minimum	Typical	Maximum	Unit
Output Power	14.0	16.0	18.0	dBm
Spectrum Mask Margin				
• 9 MHz to 11 MHz (0 ~ -20 dBr)	0			dB
• 11 MHz to 20 MHz (-20 ~ -28 dBr)	0			dB
• 20 MHz to 30 MHz (-28 ~ -45 dBr)	0			dB
• 30 MHz to 33 MHz (-45 dBr)	0			dB
4. Constellation Error (EVM) (measured at enhanced mode)			-5	dB
Frequency Tolerance	-20		20	ppm
Spurious Emissions				
• 30 - 47 MHz (BW = 100 kHz)			-36	dBm
• 47 - 74 MHz (BW = 100 kHz)			-54	dBm
• 74 - 87.5 MHz (BW = 100 kHz)			-36	dBm
• 87.5 - 118 MHz (BW = 100 kHz)			-54	dBm
• 118 - 174 MHz (BW = 100 kHz)			-36	dBm
• 174 - 230 MHz (BW = 100 kHz)			-54	dBm
• 230 - 470 MHz (BW = 100 kHz)			-36	dBm
• 470 - 862 MHz (BW = 100 kHz)			-54	dBm
• 862 - 1000 MHz (BW = 100 kHz)			-36	dBm
• 1000 - 12750 MHz (BW = 1 MHz)			-30	dBm
Rx Characteristics	Minimum	Typical	Maximum	Unit
Minimum Input Level (PER ≤ 10%)			-82	dBm
Maximum Input Level (PER < 10%)	-20			dBm
Adjacent Channel Rejection (PER ≤ 10%)	-2			dB

12.4 DC/RF Characteristics for IEEE 802.11a - 5 GHz

Table 35: Characteristics Values for IEEE 802.11a - 5 GHz

Items	Contents
Specification	IEEE 802.11a
Mode	OFDM
Channel Frequency	5180 to 5240 MHz, 5260 to 5320 MHz, 5500 to 5720 MHz, 5745 to 5825 MHz
Data Rate	6, 9, 12, 18, 24, 36, 48, 54 Mbps

12.4.1 High-Rate Condition for IEEE 802.11a - 5 GHz

Conditions: 25 °C, VBAT = 3.3V, VIO = 1.8V, Output power setting = 16 dBm at module pad, 54 Mbps mode

Table 36: High-Rate Condition for IEEE 802.11a - 5 GHz

Items	Contents			
	Minimum	Typical	Maximum	Unit
DC Characteristics				
DC Current				
• Tx mode		394	550	mA
• Rx mode		62	80	mA
Tx Characteristics				
Output Power	14.0	16.0	18.0	dBm
Spectrum Mask Margin				
• 9 MHz to 11 MHz (0 ~ -20 dBr)	0			dB
• 11 MHz to 20 MHz (-20 ~ -28 dBr)	0			dB
• 20 MHz to 30 MHz (-28 ~ -45 dBr)	0			dB
• 30 MHz to 33 MHz (-45 dBr)	0			dB
Constellation Error (EVM) (measured at enhanced mode)			-25	dB
Frequency Tolerance	-20		20	ppm
Spurious Emissions				
• 30 - 47 MHz (BW = 100 kHz)			-36	dBm
• 47 - 74 MHz (BW = 100 kHz)			-54	dBm
• 74 - 87.5 MHz (BW = 100 kHz)			-36	dBm
• 87.5 - 118 MHz (BW = 100 kHz)			-54	dBm
• 118 - 174 MHz (BW = 100 kHz)			-36	dBm
• 174 - 230 MHz (BW = 100 kHz)			-54	dBm
• 230 - 470 MHz (BW = 100 kHz)			-36	dBm
• 470 - 862 MHz (BW = 100 kHz)			-54	dBm
• 862 - 1000 MHz (BW = 100 kHz)			-36	dBm
• 1000 - 5150 MHz (BW = 1 MHz)			-30	dBm
• 5350 - 5470 MHz (BW = 1 MHz)			-30	dBm
• 5725 - 26000 MHz (BW = 1 MHz)			-30	dBm
Rx Characteristics				
Minimum Input Level (PER ≤ 10%)			-65	dBm
Maximum Input Level (PER < 10%)	-30			dBm
Adjacent Channel Rejection (PER ≤ 10%)	-1			dB

12.4.2 Low-Rate Condition for IEEE 802.11a - 5 GHz

Conditions: 25 °C, VBAT = 3.3V, VIO = 1.8V, Output power setting = 16 dBm at module pad, 6 Mbps mode

Table 37: Low-Rate Condition for IEEE 802.11a - 5 GHz

Items	Contents			
	Minimum	Typical	Maximum	Unit
DC Characteristics				
DC Current				
• Tx mode		394	550	mA
• Rx mode		62	80	mA
Tx Characteristics				
Output Power	14.0	16.0	18.0	dBm
Spectrum Mask Margin				
• 9 MHz to 11 MHz (0 ~ -20 dBr)	0			dB
• 11 MHz to 20 MHz (-20 ~ -28 dBr)	0			dB
• 20 MHz to 30 MHz (-28 ~ -45 dBr)	0			dB
• 30 MHz to 33 MHz (-45 dBr)	0			dB
Constellation Error (EVM) (measured at enhanced mode)			-5	dB
Frequency Tolerance	-20		-20	ppm
Spurious Emissions				
• 30 - 47 MHz (BW = 100 kHz)			-36	dBm
• 47 - 74 MHz (BW = 100 kHz)			-54	dBm
• 74 - 87.5 MHz (BW = 100 kHz)			-36	dBm
• 87.5 - 118 MHz (BW = 100 kHz)			-54	dBm
• 118 - 174 MHz (BW = 100 kHz)			-36	dBm
• 174 - 230 MHz (BW = 100 kHz)			-54	dBm
• 230 - 470 MHz (BW = 100 kHz)			-36	dBm
• 470 - 862 MHz (BW = 100 kHz)			-54	dBm
• 862 - 1000 MHz (BW = 100 kHz)			-36	dBm
• 1000 - 5150 MHz (BW = 1 MHz)			-30	dBm
• 5350 - 5470 MHz (BW = 1 MHz)			-30	dBm
• 5725 - 26000 MHz (BW = 1 MHz)			-30	dBm
Rx Characteristics				
Minimum Input Level (PER ≤ 10%)			-82	dBm
Maximum Input Level (PER < 10%)	-30			dBm
Adjacent Channel Rejection (PER ≤ 10%)	-1			dB

12.5 DC/RF Characteristics for IEEE 802.11n (HT20) - 5 GHz

Table 38: Characteristics Values for IEEE 802.11n (HT20) - 5 GHz

Items	Contents
Specification	IEEE 802.11n
Mode	OFDM
Channel Frequency	5180 to 5240 MHz, 5260 to 5320 MHz, 5500 to 5720 MHz, 5745 to 5825 MHz
Data Rate	MCS0-MCS7

12.5.1 High-Rate Condition for IEEE 802.11n (HT20) - 5 GHz

Conditions: 25 °C, VBAT = 3.3V, VIO = 1.8V, Output power setting = 15 dBm at module pad, MCS7 mode

Table 39: High-Rate Condition for IEEE 802.11n (HT20) - 5 GHz

Items	Contents			
	Minimum	Typical	Maximum	Unit
DC Characteristics				
DC Current				
• Tx mode		373	520	mA
• Rx mode		62	80	mA
Tx Characteristics	Minimum	Typical	Maximum	Unit
Output Power	13.0	15.0	17.0	dBm
Spectrum Mask Margin				
• 9 MHz to 11 MHz (0 ~ -20 dBr)	0			dB
• 11 MHz to 20 MHz (-20 ~ -28 dBr)	0			dB
• 20 MHz to 30 MHz (-28 ~ -45 dBr)	0			dB
• 30 MHz to 33 MHz (-45 dBr)	0			dB
Constellation Error (EVM) (measured at enhanced mode)			-27	dB
Frequency Tolerance	-20		20	ppm
Spurious Emissions				
• 30 - 47 MHz (BW = 100 kHz)			-36	dBm
• 47 - 74 MHz (BW = 100 kHz)			-54	dBm
• 74 - 87.5 MHz (BW = 100 kHz)			-36	dBm
• 87.5 - 118 MHz (BW = 100 kHz)			-54	dBm
• 118 - 174 MHz (BW = 100 kHz)			-36	dBm
• 174 - 230 MHz (BW = 100 kHz)			-54	dBm
• 230 - 470 MHz (BW = 100 kHz)			-36	dBm
• 470 - 862 MHz (BW = 100 kHz)			-54	dBm
• 862 - 1000 MHz (BW = 100 kHz)			-36	dBm
• 1000 - 5150 MHz (BW = 1 MHz)			-30	dBm
• 5350 - 5470 MHz (BW = 1 MHz)			-30	dBm
• 5725 - 26000 MHz (BW = 1 MHz)			-30	dBm
Rx Characteristics	Minimum	Typical	Maximum	Unit

Items	Contents			
Minimum Input Level (PER ≤ 10%)			-64	dBm
Maximum Input Level (PER < 10%)	-30			dBm
Adjacent Channel Rejection (PER ≤ 10%)	-2			dB

12.5.2 Low-Rate Condition for IEEE 802.11n (HT20) - 5 GHz

Conditions: 25 °C, VBAT = 3.3V, VIO = 1.8V, Output power setting = 15 dBm at module pad, MCS0 mode

Table 40: Low-Rate Condition for IEEE 802.11n (HT20) - 5 GHz

Items	Contents			
DC Characteristics	Minimum	Typical	Maximum	Unit
DC Current				
• Tx mode		373	520	mA
• Rx mode		62	80	mA
Tx Characteristics	Minimum	Typical	Maximum	Unit
Output Power	13.0	15.0	17.0	dBm
Spectrum Mask Margin				
• 9 MHz to 11 MHz (0 ~ -20 dBr)	0			dB
• 11 MHz to 20 MHz (-20 ~ -28 dBr)	0			dB
• 20 MHz to 30 MHz (-28 ~ -45 dBr)	0			dB
• 30 MHz to 33 MHz (-45 dBr)	0			dB
Constellation Error (EVM) (measured at enhanced mode)			-5	dB
Frequency Tolerance	-20		20	ppm
Spurious Emissions				
• 30 - 47 MHz (BW = 100 kHz)			-36	dBm
• 47 - 74 MHz (BW = 100 kHz)			-54	dBm
• 74 - 87.5 MHz (BW = 100 kHz)			-36	dBm
• 87.5 - 118 MHz (BW = 100 kHz)			-54	dBm
• 118 - 174 MHz (BW = 100 kHz)			-36	dBm
• 174 - 230 MHz (BW = 100 kHz)			-54	dBm
• 230 - 470 MHz (BW = 100 kHz)			-36	dBm
• 470 - 862 MHz (BW = 100 kHz)			-54	dBm
• 862 - 1000 MHz (BW = 100 kHz)			-36	dBm
• 1000 - 5150 MHz (BW = 1 MHz)			-30	dBm
• 5350 - 5470 MHz (BW = 1 MHz)			-30	dBm
• 5725 - 26000 MHz (BW = 1 MHz)			-30	dBm
Rx Characteristics	Minimum	Typical	Maximum	Unit
Minimum Input Level (PER ≤ 10%)			-82	dBm
Maximum Input Level (PER < 10%)	-30			dBm
Adjacent Channel Rejection (PER ≤ 10%)	-2			dB

12.6 DC/RF Characteristics for IEEE 802.11n (HT40) - 5 GHz

Table 41: Characteristics Values for IEEE 802.11n (HT40) - 5 GHz

Items	Contents
Specification	IEEE 802.11n
Mode	OFDM
Channel Frequency	5190 to 5795 MHz
Data Rate	MCS0-MCS7

12.6.1 High-Rate Condition for IEEE 802.11n (HT40) - 5 GHz

Conditions: 25 °C, VBAT = 3.3V, VIO = 1.8V, Output power setting = 14 dBm at module pad, MCS7 mode

Table 42: High-Rate Condition for IEEE 802.11n (HT40) - 5 GHz

Items	Contents			
DC Characteristics	Minimum	Typical	Maximum	Unit
DC Current				
• Tx mode		352	490	mA
• Rx mode		69	90	mA
Tx Characteristics	Minimum	Typical	Maximum	Unit
Output Power	12.0	14.0	16.0	dBm
Spectrum Mask Margin				
• 19 MHz to 21 MHz (0 ~ -20 dBr)	0			dB
• 21 MHz to 40 MHz (-20 ~ -28 dBr)	0			dB
• 40 MHz to 60 MHz (-28 ~ -45 dBr)	0			dB
• 60 MHz to 80 MHz (-45 dBr)	0			dB
Constellation Error (EVM) (measured at enhanced mode)			-27	dB
Frequency Tolerance	-20		20	ppm
Spurious Emissions				
• 30 - 47 MHz (BW = 100 kHz)			-36	dBm
• 47 - 74 MHz (BW = 100 kHz)			-54	dBm
• 74 - 87.5 MHz (BW = 100 kHz)			-36	dBm
• 87.5 - 118 MHz (BW = 100 kHz)			-54	dBm
• 118 - 174 MHz (BW = 100 kHz)			-36	dBm
• 174 - 230 MHz (BW = 100 kHz)			-54	dBm
• 230 - 470 MHz (BW = 100 kHz)			-36	dBm
• 470 - 862 MHz (BW = 100 kHz)			-54	dBm
• 862 - 1000 MHz (BW = 100 kHz)			-36	dBm
• 1000 - 5150 MHz (BW = 1 MHz)			-30	dBm
• 5350 - 5 470 MHz (BW = 1 MHz)			-30	dBm
• 5725 - 26000 MHz (BW = 1 MHz)			-30	dBm
Rx Characteristics	Minimum	Typical	Maximum	Unit
Minimum Input Level (PER ≤ 10%)			-61	dBm
Maximum Input Level (PER ≤ 10%)	-30			dBm
Adjacent Channel Rejection (PER ≤ 10%)	-2			dB

12.6.2 Low-Rate Condition for IEEE 802.11n (HT40) - 5 GHz

Conditions: 25 °C, VBAT = 3.3V, VIO = 1.8V, Output power setting = 14 dBm at module pad, MCS0 mode.

Table 43: Low-Rate Condition for IEEE 802.11n (HT40) - 5 GHz

Items	Contents			
	Minimum	Typical	Maximum	Unit
DC Characteristics				
DC Current				
• Tx mode		352	490	mA
• Rx mode		69	90	mA
Tx Characteristics				
Output Power	12.0	14.0	16.0	dBm
Spectrum Mask Margin				
• 19 MHz to 21 MHz (0 ~ -20 dBr)	0			dB
• 21 MHz to 40 MHz (-20 ~ -28 dBr)	0			dB
• 40 MHz to 60 MHz (-28 ~ -45 dBr)	0			dB
• 60 MHz to 80 MHz (-45 dBr)	0			dB
Constellation Error (EVM) (measured at enhanced mode)			-5	dB
Frequency Tolerance	-20		20	ppm
Spurious Emissions				
• 30 - 47 MHz (BW = 100 kHz)			-36	dBm
• 47 - 74 MHz (BW = 100 kHz)			-54	dBm
• 74 - 87.5 MHz (BW = 100 kHz)			-36	dBm
• 87.5 - 118 MHz (BW = 100 kHz)			-54	dBm
• 118 - 174 MHz (BW = 100 kHz)			-36	dBm
• 174 - 230 MHz (BW = 100 kHz)			-54	dBm
• 230 - 470 MHz (BW = 100 kHz)			-36	dBm
• 470 - 862 MHz (BW = 100 kHz)			-54	dBm
• 862 - 1000 MHz (BW = 100 kHz)			-36	dBm
• 1000 - 5150 MHz (BW = 1 MHz)			-30	dBm
• 5350 - 5470 MHz (BW = 1 MHz)			-30	dBm
• 5725 - 26000 MHz (BW = 1 MHz)			-30	dBm
Rx Characteristics				
Minimum Input Level (PER ≤ 10%)			-79	dBm
Maximum Input Level (PER ≤ 10%)	-30			dBm
Adjacent Channel Rejection (PER ≤ 10%)	-2			dB

12.7 DC/RF Characteristics for Bluetooth

Table 44: Characteristics Values for Bluetooth

Items	Contents
Bluetooth specification (power class)	Version 5.2 (Class 1)
Channel Frequency (spacing)	2402 to 2480 MHz (1 MHz)
Number of RF Channel	79

12.7.1 Basic Data Rate Condition

Conditions: 25 °C, VBAT = 3.3V, VIO = 1.8V (Test method: Bluetooth Core Spec Vol.3 Part D)

Table 45: Basic Data Rate Condition

Items	Contents			
	Minimum	Typical	Maximum	Unit
Current Consumption				
• Tx mode DH5		84	110	mA
• Rx mode DH5		65	90	mA
Tx Characteristics	Minimum	Typical	Maximum	Unit
Output Power@DH5	0	3.0	6.3	dBm
Frequency range	2400		2483.5	MHz
20 dB bandwidth			1	MHz
Adjacent Channel Power ⁸				
• [M-N] = 2			-20	dBm
• [M-N] ≥ 3			-40	dBm
Modulation characteristics				
• Modulation $\Delta f_{1\text{avg}}$	140	151	175	kHz
• Modulation $\Delta f_{2\text{max}}$	115			kHz
• Modulation $\Delta f_{2\text{avg}} / \Delta f_{1\text{avg}}$	0.8	1		
Carrier Frequency Drift				
• 1slot	-25		25	kHz
• 3slot / 5slot	-40		40	kHz
• Maximum Drift Rate			20	kHz/50 μ s
Rx Characteristics	Minimum	Typical	Maximum	Unit
BDR Sensitivity (BER ≤ 0.1%)		-93	-70	dBm
Maximum Input Level (BER ≤ 0.1%)	-20			dBm

⁸ Up to three spurious responses within Bluetooth limits are allowed.

12.7.2 Enhanced Data Rate Condition

Conditions: 25 °C, VBAT = 3.3V, VIO = 1.8V (Test method: Bluetooth Core Spec Vol.3 Part D)

Table 46: Enhanced Data Rate Condition

Items	Contents			
Current Consumption	Minimum	Typical	Maximum	Unit
• Tx mode 2DH5		81	110	mA
• Rx mode 2DH5		65	90	mA
• Tx mode 3DH5		81	110	mA
• Rx mode 3DH5		65	90	mA
Tx Characteristics	Minimum	Typical	Maximum	Unit
Output Power@2DH5/3DH5	-3.0	0	3.3	dBm
Frequency range	2400		2483.5	MHz
20 dB bandwidth			1	MHz
Adjacent Channel Power ⁹				
• [M-N] = 2			-20	dBm
• [M-N] ≥ 3			-40	dBm
EDR Relative Power	-4		1	dB
EDR Carrier Frequency Stability and Modulation Accuracy				
• ω_i	-75		75	kHz
• $\omega_i + \omega_o$	-75		75	kHz
• ω_o	-10		10	kHz
• RMS DEVM (DQPSK)			20	%
• Peak DEVM (DQPSK)			35	%
• 99% DEVM (DQPSK)			30	%
• RMS DEVM (8DPSK)			13	%
• Peak DEVM (8DPSK)			25	%
• 99% DEVM (8DPSK)			20	%
Spurious Emissions				
• 30 - 47 MHz (BW = 100 kHz)			-36	dBm
• 47 - 74 MHz (BW = 100 kHz)			-54	dBm
• 74 - 87.5 MHz (BW = 100 kHz)			-36	dBm
• 87.5 - 118 MHz (BW = 100 kHz)			-54	dBm
• 118 - 174 MHz (BW = 100 kHz)			-36	dBm
• 174 - 230 MHz (BW = 100 kHz)			-54	dBm
• 230 - 470 MHz (BW = 100 kHz)			-36	dBm
• 470 - 862 MHz (BW = 100 kHz)			-54	dBm
• 862 - 1000 MHz (BW = 100 kHz)			-36	dBm
• 1000 - 12750 MHz (BW = 1 MHz)			-30	dBm
Rx Characteristics	Minimum	Typical	Maximum	Unit
EDR Sensitivity (BER ≤ 0.007%@8DPSK)		-87	-70	dBm
Maximum Input Level (BER ≤ 0.1%)	-20			dBm

⁹ Up to three spurious responses within Bluetooth limits are allowed.

12.8 DC/RF Characteristics for Bluetooth Low Energy

Table 47: Characteristics Values for BLE

Items	Contents
Bluetooth specification (power class)	Version 5.2 (Class 1.5)
Channel Frequency (spacing)	2402 to 2480 MHz (2 MHz)
Number of RF Channel	40

12.8.1 1 Mbps PHY Condition

Conditions: 25 °C, VBAT = 3.3V, VIO = 1.8V (Test method: Bluetooth Core Spec Vol.6 Part F)

Table 48: 1 Mbps PHY Condition

Items	Contents			
Current Consumption	Minimum	Typical	Maximum	Unit
• Tx mode		80	110	mA
• Rx mode		73	95	mA
Tx Characteristics	Minimum	Typical	Maximum	Unit
Center Frequency	2402		2480	MHz
Channel Spacing		2		MHz
Number of RF channel		40		
Output Power	0	3.0	6.3	dBm
In-band emission				
• $f_{TX} \pm 2$ MHz			-20	dBm
• $f_{TX} \pm [3+n]$ MHz; n = 0,1,2...			-30	dBm
Modulation Characteristics				
• $\Delta f_{1\text{avg}}$	225		275	kHz
• $\Delta f_{2\text{max}}$ (at 99.9%)	185			kHz
• $\Delta f_{2\text{avg}} / \Delta f_{1\text{avg}}$	0.8			
Stable Modulation Characteristics				
• $\Delta f_{1\text{avg}}$	247.5		252.5	kHz
• $\Delta f_{2\text{max}}$ (at 99.9%)	185			kHz
• $\Delta f_{2\text{avg}} / \Delta f_{1\text{avg}}$	0.8			
Carrier frequency offset and drift				
• Frequency offset (f_n); n = 0,1,2,3...k	-150		150	kHz
• Frequency drift ($ f_0 - f_n $); n = 2,3,4...k			50	kHz
• Drift rate				
• $ f_1 - f_0 $			23	kHz
• $ f_n - f_{n-5} $; n = 6,7, 8,...k			20	kHz
Spurious Emissions				
• 30 - 47 MHz (BW = 100 kHz)			-36	dBm
• 47 - 74 MHz (BW = 100 kHz)			-54	dBm
• 74 - 87.5 MHz (BW = 100 kHz)			-36	dBm
• 87.5 - 118 MHz (BW = 100 kHz)			-54	dBm
• 118 - 174 MHz (BW = 100 kHz)			-36	dBm
• 174 - 230 MHz (BW = 100 kHz)			-54	dBm
• 230 - 470 MHz (BW = 100 kHz)			-36	dBm
• 470 - 862 MHz (BW = 100 kHz)			-54	dBm
• 862 - 1000 MHz (BW = 100 kHz)			-36	dBm

Items	Contents			
<ul style="list-style-type: none"> 1000 - 12750 MHz (BW = 1 MHz) 			-30	dBm
Rx Characteristics	Minimum	Typical	Maximum	Unit
Receiver Sensitivity (PER < 30.8%)		-101	-70	dBm
Maximum input signal level (PER < 30.8%)	-10			dBm
PER Report Integrity (-30 dBm input)	50		65.4	%

12.8.2 2 Mbps PHY Condition

Conditions: 25 °C, VBAT = 3.3V, VIO = 1.8V (Test method: Bluetooth Core Spec Vol.6 Part F)

Table 49: 2 Mbps PHY Condition

Items	Contents			
Current Consumption	Minimum	Typical	Maximum	Unit
<ul style="list-style-type: none"> Tx mode Rx mode 		76 73	100 95	mA mA
Tx Characteristics	Minimum	Typical	Maximum	Unit
Center Frequency	2402		2480	MHz
Channel Spacing		2		MHz
Number of RF channel		40		
Output Power	0	3.0	6.3	dBm
In-band emission				
<ul style="list-style-type: none"> $f_{TX} \pm 4$ MHz $f_{TX} \pm 5$ MHz $f_{TX} \pm [6+n]$ MHz; $n = 0, 1, 2, \dots$ 			-20 -20 -30	dBm dBm dBm
Modulation Characteristics				
<ul style="list-style-type: none"> Δf_{1avg} Δf_{2max} (at 99.9%) $\Delta f_{2avg} / \Delta f_{1avg}$ 	450 370 0.8		550	kHz kHz
Stable Modulation Characteristics				
<ul style="list-style-type: none"> Δf_{1avg} Δf_{2max} (at 99.9%) $\Delta f_{2avg} / \Delta f_{1avg}$ 	495 370 0.8		505	kHz kHz
Carrier frequency offset and drift				
<ul style="list-style-type: none"> Frequency offset (f_n); $n = 0, 1, 2, 3, \dots, k$ Frequency drift ($f_0 - f_n$); $n = 2, 3, 4, \dots, k$ Drift rate <ul style="list-style-type: none"> $f_1 - f_0$ $f_n - f_{n-5}$; $n = 6, 7, 8, \dots, k$ 	-150		150 50 23 20	kHz kHz kHz kHz
Spurious Emissions				
<ul style="list-style-type: none"> 30 - 47 MHz (BW = 100 kHz) 47 - 74 MHz (BW = 100 kHz) 74 - 87.5 MHz (BW = 100 kHz) 87.5 - 118 MHz (BW = 100 kHz) 118 - 174 MHz (BW = 100 kHz) 174 - 230 MHz (BW = 100 kHz) 230 - 470 MHz (BW = 100 kHz) 470 - 862 MHz (BW = 100 kHz) 862 - 1000 MHz (BW = 100 kHz) 			-36 -54 -36 -54 -36 -54 -36 -54	dBm dBm dBm dBm dBm dBm dBm dBm

Items	Contents			
• 1000 - 12750 MHz (BW = 1 MHz)			-30	dBm
Rx Characteristics	Minimum	Typical	Maximum	Unit
Receiver Sensitivity (PER < 30.8%)		-99	-70	dBm
Maximum Input Signal Level (PER < 30.8%)	-10			dBm
PER Report Integrity (-30 dBm input)	50		65.4	%

13 Land Pattern

The land pattern is shown in **Figure 21**.

Figure 21: Land Pattern

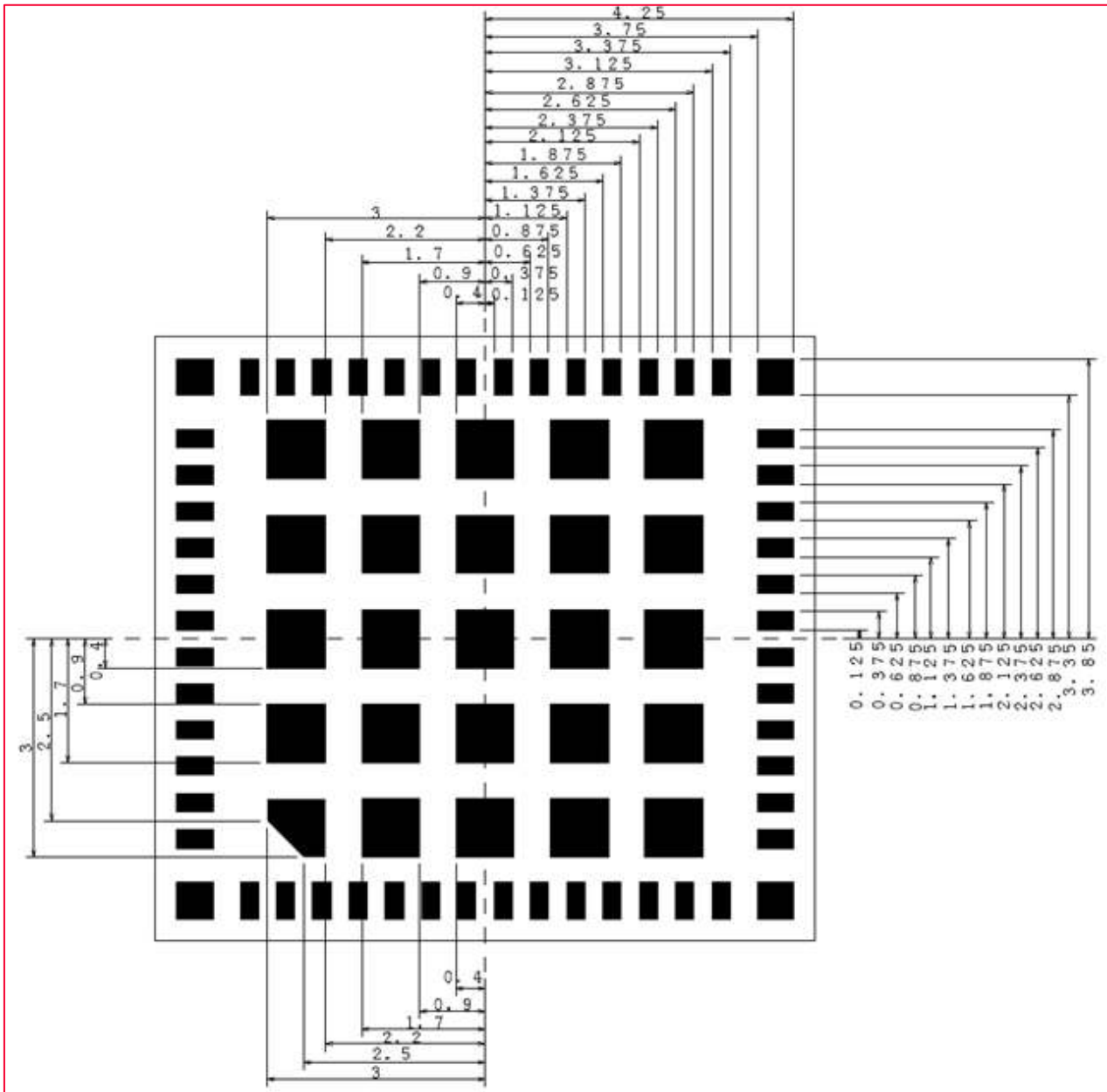

To avoid the short-circuit between the side shielding and a solder on the module land after the reflow, please locate the module land at 0.2 mm away from module outline as above figure.

14 General Radio Regulatory Certification for LBEE5CJ1XK and LBEE5CJ2XK

This section contains the following topics:

- Application model part number
- Label
- Package Label
- Country of Origin

14.1 Application Model Part Number

Basically, we apply for “LBEE5CJ1XK” and “LBEE5CJ2XK” in each country.

14.2 Label

Figure 22 shows the certification label of Type 1XK module.

Figure 22: Radio Regulatory Certification Label

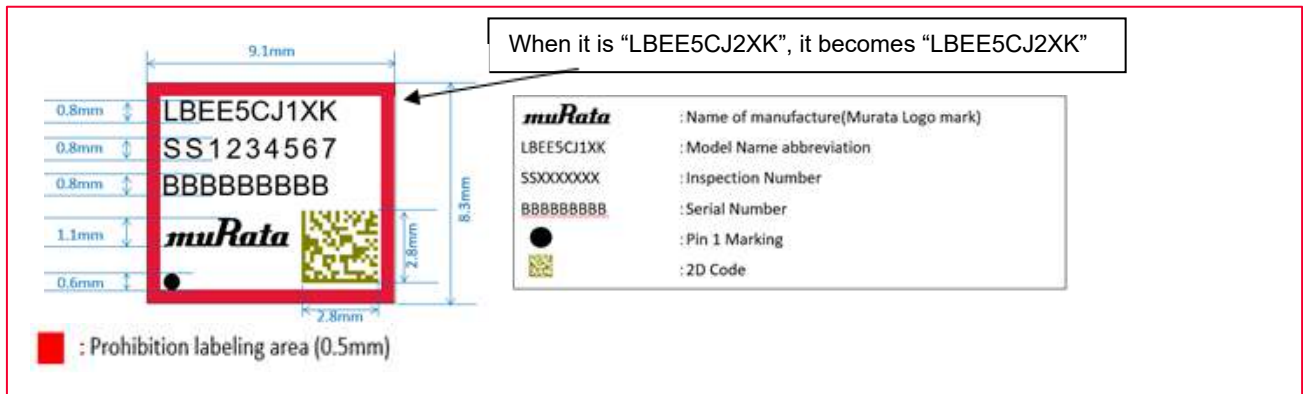

Since there is no space to describe the notational requirements of each country, we are applying for the notational requirements to be posted in the manual or package.

14.3 Package Label

Figure 23 shows the package label information (Humidity Proof Packing)

Figure 23: Package Label (Humidity Proof Packing)

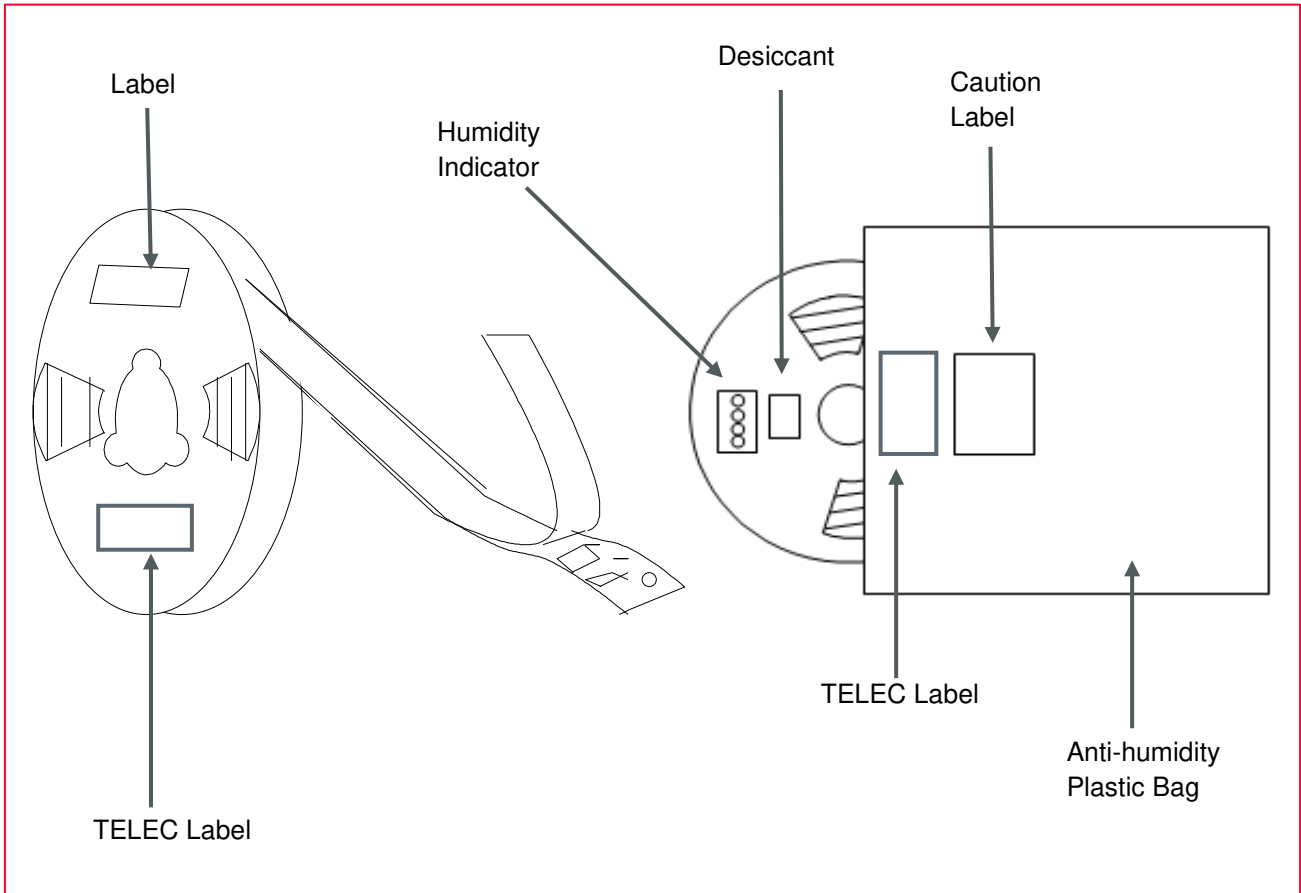

The package label may be attached on one side only.

Package label display example is shown in **Figure 24**.

Figure 24: Package Label Display Example





The above pictures are examples. It may be attached to only one of them.

14.4 Country of Origin

China

SHENZHEN MURATA TECHNOLOGY CO., LTD.

Some countries have applied for two countries, China, and Japan, in preparation for future factory changes, but the production site in the delivery specifications is the above-mentioned factory in China.

15 Radio Regulatory Certification by Country for LBEE5CJ1XK and LBEE5CJ2XK

This section includes regulatory certification information all the following countries:

- Japan
- FCC
- ISED
- Europe



Precautions when using report number:

E2/2021/30010 ~ E2/2021/30015 (RF Conducted test result only) for final product DoC.

15.1 Japan

- Manufacturer: Murata Manufacturing Co., Ltd.
- Model or Product Name: LBEE5CJ1XK or LBEE5CJ2XK
- This module has received "CERTIFICATION for TYPE CERTIFICATION" under the Japanese Radio Act.

Japanese Version

電波法の要求に基づく警告

警告) 5 GHz の周波数帯においては、5.2 GHz/5.3 GHz/5.6 GHz 帯(W52/W53/W56)の3種類の帯域を使用することができます。5.2 GHz/5.3 GHz 帯無線 LAN(W52/W53)の屋外使用は5.2 GHz 帯高出力データ通信システムの基地局又は陸上移動中継局と通信する場合を除き電波法で禁止されています。

English Version

Warning based on the requirements of Japanese Radio Act

(Warning) In the 5 GHz frequency band, you can use 3 bands: 5.2 GHz/5.3 GHz/5.6 GHz (W52/W53/W56).

Outdoor use of 5.2 GHz/5.3 GHz band wireless LANs(W52/W53) is prohibited by the Radio Act except when communicating with 5.2 GHz band high-power data communication system base stations or land mobile relay stations.

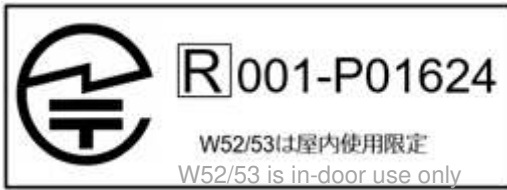

15.1.1 Power Level for Japan

Table 50 and **Table 51** shows the per antenna port power table for 2.4 GHz for WLAN and Bluetooth. **Table 52** shows the per antenna port power table for 5 GHz WLAN.

Table 50: Japan Power Level 2.4 GHz WLAN Per Antenna Port

Mode	Rate	Channel	Maximum Tune Up Tolerance [dBm]
IEEE 802.11b	All Rates	1 ~ 13	16.0 ± 2.0
IEEE 802.11g	6 Mbps, 9 Mbps, 12 Mbps, 18 Mbps	1 ~ 13	17.0 ± 2.0
	24 Mbps, 36 Mbps, 48 Mbps, 54 Mbps	1 ~ 13	16.0 ± 2.0
IEEE 802.11n (HT20)	MCS0, MCS1, MCS2	1 ~ 13	16.0 ± 2.0
	MCS3, MCS4, MCS5, MCS6, MCS7	1 ~ 13	15.0 ± 2.0

Table 51: Japan Power Level 2.4 GHz BT/BLE Per Antenna Port

Mode	Maximum Tune Up Tolerance [dBm]	
	Shared BT Antenna (PIN No. 45)	Dedicated BT Antenna (PIN No. 47)
BR	3.0 ± 3.0	3.3 ± 3.0
EDR	0.0 ± 3.0	0.3 ± 3.0
LE	3.0 ± 3.0	3.3 ± 3.0
LE 2 Mbps	3.0 ± 3.0	3.3 ± 3.0
LE (Long Range) 125 kbps	3.0 ± 3.0	3.3 ± 3.0
LE (Long Range) 500 kbps	3.0 ± 3.0	3.3 ± 3.0

Table 52: Japan Power Level 5 GHz WLAN Per Antenna Port

Mode	Rate	Band	Channel	Maximum Tune Up Tolerance [dBm]
IEEE 802.11a	All Rates	W52/W53	36 ~ 64	14.0 ± 2.0
	All Rates	W56	100 ~ 144	15.0 ± 2.0
IEEE 802.11n (HT20)	All Rates	W52/W53	36 ~ 64	14.0 ± 2.0
	All Rates	W56	100 ~ 144	14.0 ± 2.0
IEEE 802.11n (HT40)	All Rates	W52/W53	38 ~ 62	14.0 ± 2.0
	All Rates	W56	102 ~ 142	14.0 ± 2.0

15.1.2 Theory of Operation for Japan

Table 53 and **Table 54** show the theory of operation for WLAN and Bluetooth.

Table 53: Japan Theory of Operation for WLAN

Frequency of Operation			Scan	Ad-hoc Mode
2.4 GHz	11b/g/n (HT20)	2412 - 2462 MHz	Active	Yes
W52	11a/n (HT20)	5180 - 5240 MHz	Active	Yes
	11n (HT40)	5190 - 5230 MHz	Active	Yes
W53	11a/n (HT20)	5260 - 5320 MHz	Passive	No
	11n (HT40)	5270 - 5310 MHz	Passive	No
W56	11a/n (HT20)	5500 - 5720 MHz	Passive	No
	11n (HT40)	5510 - 5710 MHz	Passive	No



DFS MASTER function not available.

DFS client function available.

There is a TPC function.

Table 54: Japan Theory of Operation for Bluetooth

Frequency of Operation			Scan	Ad-hoc Mode
BT	BR	2402 ~ 2480 MHz	N/A	N/A
	EDR	2402 ~ 2480 MHz	N/A	N/A
LE	LE	2402 ~ 2480 MHz	N/A	N/A
	LE 2 Mbps	2402 ~ 2480 MHz	N/A	N/A
	LE (Long Range) 125 kbps	2402 ~ 2480 MHz	N/A	N/A
	LE (Long Range) 500 kbps	2402 ~ 2480 MHz	N/A	N/A



Without simultaneous transmission in the same frequency band.

TPC supported.

Setting value is typical WLAN deviation is ± 2 dB, BT/BLE deviation is ± 3 dB.

15.1.3 Antenna List

The antennas are registered under the Japan Radio Act. These are shown in the tables below.

- Antenna 1

Antenna name	LBEE5CJ1XK-Antenna
Antenna vendor	muRata
Antenna type	Monopole antenna
Antenna gain	+3.6dBi@2400 MHz
	+4.6dBi@5500 MHz
Frequency	2400 - 2484 MHz
	5150 - 5850 MHz

- Antenna 2

Antenna name	146153
Antenna vendor	Molex
Antenna type	Dipole antenna
Antenna gain	<u>+3.2dBi@2.4 GHz</u>
	<u>+4.25dBi@5 GHz</u>
Frequency	2400 - 2500 MHz
	5150 - 5850 MHz

- Antenna 3

Antenna name	146187
Antenna vendor	Molex
Antenna type	Dipole antenna
Antenna gain	<u>+3.4dBi@2.4 GHz</u>
	<u>+4.75dBi@5 GHz</u>
Frequency	2400 - 2500 MHz
	5150 - 5850 MHz

- Antenna 4

Antenna name	206994
Antenna vendor	Molex
Antenna type	Monopole antenna
Antenna gain	<u>+3.6dBi@2.4 GHz</u>
	<u>+3.6dBi@5 GHz</u>
Frequency	2400 - 2500 MHz
	5150 - 5850 MHz



15.1.4 About Notations

It is recommended that the indication of (1) or (2) below is described on the product incorporating this module *in Japanese*. If there is any problem with the indication of (1) or (2) on the product, we recommend indicating (1) or (2) in the user manual or on the package of the product incorporating this module, or electronic display on the product. In the case of the electronic display, it is necessary to describe "using the electronic display" + "how to reach to below indication" in the user manual of the product.

- Recommended Indication 1

Japanese Version 本製品は、電波法に基づく工事設計認証(認証番号:001-P01624)を受けた特定無線設備を内蔵しています。
English Version This product incorporates specified radio equipment that has received CERTIFICATION for TYPE CERTIFICATION (certification number: 001-P01624) based on the Japan Radio Act.

- Recommended Indication 2

Japanese Version  R001-P01624 5.2 GHz/5.3 GHz 帯無線 LAN (W52/W53) の屋外使用は 5.2 GHz 帯高出力データ通信システムの基地局又は陸上移動中継局と通信する場合を除き電波法で禁止されています。
English Version  R001-P01624 Outdoor use of 5.2 GHz/5.3 GHz band wireless LANs (W52/W53) is prohibited by the Radio Act except when communicating with 5.2 GHz band high-power data communication system base stations or land mobile relay stations.

15.1.5 Model Number Change

This module had been certified with model number LBEE5CJ1XK, but model number has been changed from “LBEE5CJ1XK” or “LBEE5CJ2XK” with approval of Ministry of Internal Affairs and Communication (MIC). **Table 55** shows the detailed information about notification to MIC.

Table 55: Detail of Notification to MIC

Change	Model Number or Product Name	Changer Date	Reason for Change
Before change	LBEE5CJ1XK	August 19, 2021	This module has already been certified with the model or name LBEE5CJ1XK and certification number 001-P01624.
After change	LBEE5CJ1XK or LBEE5CJ2XK		

This is an authentication that allows both "configuration of WLAN / BT common antenna settings" and "configuration of BT dedicated antenna settings" as shown in **Figure 25**.

However, because management becomes complicated, we newly installed a module with the same design except for the model’s name as LBEE5CJ2XK and added and changed the product name to determine the configuration of the default antenna setting for each.

- LBEE5CJ1XK: Default configuration is shared Bluetooth/WLAN antenna
- LBEE5CJ2XK: Default configuration is dedicated Bluetooth antenna and WLAN antenna

Figure 25: Shared Bluetooth/WLAN Antenna and Dedicated Bluetooth/WLAN Antenna

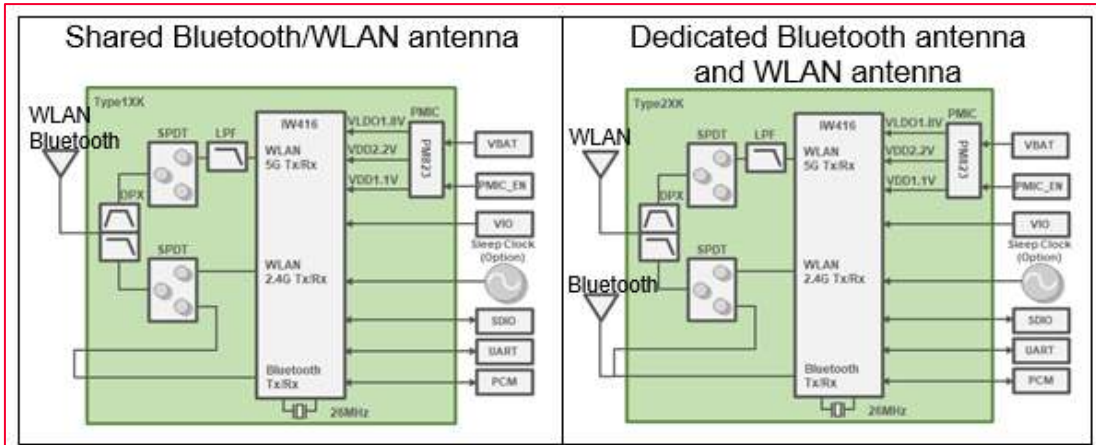

15.2 FCC

FCC ID: VPYLB1XK

This module is not directly sold to general end users. Therefore, there is no user manual of module. For the details about this module, please refer to the specification sheet of module.



1. This module should be installed in the host device according to the interface specification (installation procedure).
2. The OEM integrator has to be aware not to provide information to the end user regarding how to install or remove this RF module in the end user's manual of the end product which integrates this module.

The end user manual shall include all required regulatory information/warning as shown in User manual.



1. This device complies with part 15 of the FCC Rules. Operation is subject to the following two conditions: (1) This device may not cause harmful interference, and (2) this device must accept any interference received, including interference that may cause undesired operation.
2. FCC CAUTION Changes or modifications not expressly approved by the party responsible for compliance could void the user's authority to operate the equipment.
3. This transmitter must not be co-located or operated in conjunction with any other antenna or transmitter.
4. This device complies with below part 15 of the FCC Rules.
 - Part 15 Subpart C
 - Part 15 Subpart E
5. Since there is no space which indicates FCC ID on this module, FCC ID is indicated in a manual. If the FCC ID is not visible when the module is installed inside another device, then the module is installed must also display a label referring to the enclosed module.

Table 56 shows the antenna list.

Table 56: Antenna List

Part number	Vendor	Peak Gain[dBi]		Type	Connector
		2.4 GHz	5 GHz		
146153	Molex	3.2	4.25	Dipole	u.FL
146187	Molex	3.4	4.75	Dipole	u.FL
LBEE5CJ1XK-Antenna	Murata	3.6	4.6	Monopole	

15.2.1 Information to Display on Host Device and User Manual

15.2.1.1 Information on Host Device

The following information must be indicated on the host device of this module.

- Contains Transmitter Module FCC ID: VPYLB1XK or Contains FCC ID: VPYLB1XK



This device complies with part 15 of the FCC Rules. Operation is subject to the following two conditions:

- This device may not cause harmful interference.
- This device must accept any interference received, including interference that may cause undesired operation.



If it is difficult to describe this statement on the host device due to the size, please describe in the user's manual and also either describe on the device packaging or on a removable label attached to the device.

15.2.1.2 Information in User Manual

The following statements must be described on the user manual of the host device of this module:

- **FCC CAUTION:** Changes or modifications not expressly approved by the party responsible for compliance could void the user's authority to operate the equipment.
- This transmitter must not be co-located or operated in conjunction with any other antenna or transmitter.

15.2.2 Equipment Installation for FCC

There are two types of installation for host device.

15.2.2.1 Portable Equipment

Equipment for which the spaces between human body and antenna are used within 20 cm.



It is necessary to take a SAR test with your set mounting this module. Class II permissive change application is necessary using the SAR report. Please contact Murata.

15.2.2.2 Mobile Equipment

Equipment used at position in which the spaces between human body and antenna exceeded 20 cm.



This equipment complies with FCC radiation exposure limits set forth for an uncontrolled environment and meets the FCC radio frequency (RF) Exposure Guidelines. This equipment should be installed and operated keeping the radiator at least 20 cm or more away from person's body.

15.2.3 Compliance with FCC Requirement 15.407(c)

Data transmission is always initiated by software, which is the passed down through the MAC, through the digital and analog baseband, and finally to the RF chip. Several special packets are initiated by the MAC. These are the only ways the digital baseband portion will turn on the RF transmitter, which it then turns off at the end of the packet. Therefore, the transmitter will be on only while one of the aforementioned packets is being transmitted. In other words, this device automatically discontinues transmission in case of either absence of information to transmit or operational failure.



Frequency Tolerance: ± 20 ppm

15.2.4 Product Dimensions

Figure 26 shows the product dimension of Type 1XK module.

Figure 26: Product Dimension

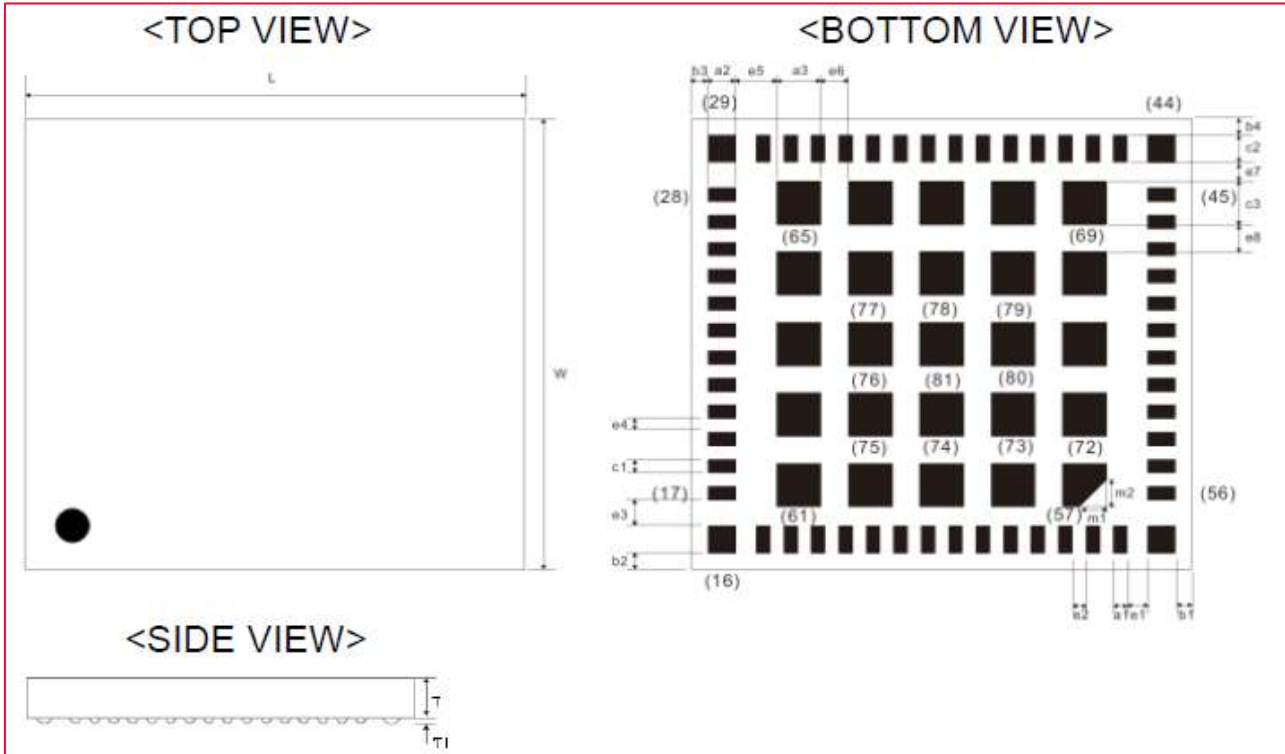

Table 57 shows the product dimensions. The dimension's unit are in mm.

Table 57: Dimensions

Mark	Dimensions	Mark	Dimensions	Mark	Dimensions	Mark	Dimensions
L	9.1 ± 0.2	W	8.3 ± 0.2	T	1.3 maximum	a1	0.25 ± 0.1
a2	0.5 ± 0.1	a3	0.8 ± 0.2	b1	0.3 ± 0.2	b2	0.3 ± 0.2
b3	0.3 ± 0.2	b4	0.3 ± 0.2	c1	0.25 ± 0.1	c2	0.5 ± 0.1
c3	0.8 ± 0.1	e1	0.38 ± 0.1	e2	0.25 ± 0.1	e3	0.48 ± 0.1
e4	0.25 ± 0.1	e5	0.75 ± 0.1	e6	0.5 ± 0.1	e7	0.35 ± 0.1
e8	0.5 ± 0.1	m1	0.5 ± 0.2	m2	0.5 ± 0.2	T1	0.045 typical



T dimension does not include height of solder bumps.

15.2.5 Supply Voltage

Table 58 shows the supply voltage information.

Table 58: Supply Voltage

PIN Name	Minimum	Typical	Maximum	Unit
VBAT	2.7	3.3	5.5	V
VIO	1.62	1.8 or 3.3	3.47	V



VIO does not affect RF characteristics.

15.2.6 Temperature

Table 59 shows the temperature information for 1XK module.

Table 59: Temperature

Operational Temperature	Minimum	Typical	Maximum	Unit
	-40	25	85	°C

15.2.7 Power Level for FCC

Table 60 and **Table 61** shows the per antenna port power table for 2.4 GHz for WLAN and Bluetooth. **Table 62** shows the per antenna port power table for 5 GHz WLAN.

Table 60: FCC Power Level 2.4 GHz WLAN Per Antenna Port

Mode	Rate	Channel	Maximum Tune Up Tolerance [dBm]
IEEE 802.11b	All Rates	1 ~ 11	17.0 ± 2.0
IEEE 802.11g	All Rates	1 ~ 3, 9 ~ 11	14.0 ± 2.0
	6 Mbps, 9 Mbps, 12 Mbps, 18 Mbps	4 ~ 8	17.0 ± 2.0
	24 Mbps, 36 Mbps, 48 Mbps, 54 Mbps	4 ~ 8	16.0 ± 2.0
IEEE 802.11n (HT20)	All Rate	1 ~ 3, 9 ~ 11	13.0 ± 2.0
	MCS0, MCS1, MCS2	4 ~ 8	16.0 ± 2.0
	MCS3, MCS 4, MCS 5, MCS 6, MCS7	4 ~ 8	15.0 ± 2.0

Table 61: FCC Power Level 2.4 GHz BT/BLE Per Antenna Port

Mode	Maximum Tune Up Tolerance [dBm]	
	Shared BT Antenna (PIN No. 45)	Dedicated BT Antenna (PIN No. 47)
BR	3.0 ± 3.0	3.3 ± 3.0
EDR	0.0 ± 3.0	0.3 ± 3.0
LE	3.0 ± 3.0	3.3 ± 3.0

Mode	Maximum Tune Up Tolerance [dBm]	
	Shared BT Antenna (PIN No. 45)	Dedicated BT Antenna (PIN No. 47)
LE 2 Mbps	3.0 ± 3.0	3.3 ± 3.0
LE (Long Range) 125 kbps	3.0 ± 3.0	3.3 ± 3.0
LE (Long Range) 500 kbps	3.0 ± 3.0	3.3 ± 3.0

Table 62: FCC Power Level 5 GHz Per Antenna Port

Mode	Rate	Band	Channel	Maximum Tune Up Tolerance [dBm]
IEEE 802.11a	All Rates	W52/W53	36, 64	14.0 ± 2.0
	All Rates	W52/W53	40 ~ 60	16.0 ± 2.0
	All Rates	W56	100, 144	14.0 ± 2.0
	All Rates	W56	104 ~ 140	15.0 ± 2.0
	All Rates	W58	149 ~ 165	15.0 ± 2.0
IEEE 802.11n (HT20)	All Rates	W52/W53	36, 64	13.0 ± 2.0
	All Rates	W52/W53	40 ~ 60	15.0 ± 2.0
	All Rates	W56	100, 144	13.0 ± 2.0
	All Rates	W56	104 ~ 140	14.0 ± 2.0
	All Rates	W58	149 ~ 165	14.0 ± 2.0
IEEE 802.11n (HT40)	All Rates	W52/W53	38, 62	12.0 ± 2.0
	All Rates	W52/W53	46 ~ 54	14.0 ± 2.0
	All Rates	W56	102, 142	12.0 ± 2.0
	All Rates	W56	110 ~ 134	14.0 ± 2.0
	All Rates	W58	151, 159	14.0 ± 2.0

15.2.8 Theory of Operation for FCC

Table 63 shows the theory of operation for WLAN and **Table 64** shows theory of operation for Bluetooth/LE.

Table 63: FCC Theory of Operation for WLAN

Frequency of Operation			Scan	Ad-hoc mode
2.4 GHz	11b/g/n (HT20)	2412 - 2462 MHz	Active	Yes
W52	11a/n (HT20)	5180 - 5240 MHz	Active	Yes
	11n (HT40)	5190 - 5230 MHz	Active	Yes
W53	11a/n (HT20)	5260 - 5320 MHz	Passive	No
	11n (HT40)	5270 - 5310 MHz	Passive	No
W56	11a/n (HT20)	5500 - 5720 MHz	Passive	No
	11n (HT40)	5510 - 5710 MHz	Passive	No
W58	11a/n (HT20)	5745 - 5825 MHz	Active	Yes
	11n (HT40)	5755 - 5795 MHz	Active	Yes



DFS MASTER function not available.
 DFS client function available.
 There is a TPC function.

Table 64: FCC Theory of Operation for Bluetooth

Frequency of Operation		Scan	Ad-hoc mode
BT	BR	2402 ~ 2480 MHz	N/A
	EDR	2402 ~ 2480 MHz	N/A
LE	LE	2402 ~ 2480 MHz	N/A
	LE 2 Mbps	2402 ~ 2480 MHz	N/A
	LE (Long Range) 125 kbps	2402 ~ 2480 MHz	N/A
	LE (Long Range) 500 kbps	2402 ~ 2480 MHz	N/A

15.2.9 About LBEE5CJ1XK and LBEE5CJ2XK

This FCC modular approval with FCC ID: VPYLB1XK has been granted with LBEE5CJ1XK as the original certification model.

This is a certification that allows both “configuration of WLAN/BT shared antenna setting” and “configuration of BT dedicated antenna setting”.

However, due to the complexity of management, a module with the same design except for the model’s name and newly created as “LBEE5CJ2XK”. And we made an addition and change of the product name to decide the configuration of the default antenna setting for each. This is a Class I permissive change.

- LBEE5CJ1XK: default is used with WLAN/BT shared antenna setting
- LBEE5CJ2XK: default is used with WLAN/BT dedicated antenna setting

Figure 27: Antenna Configuration for Type 1XK and Type 2XK Modules

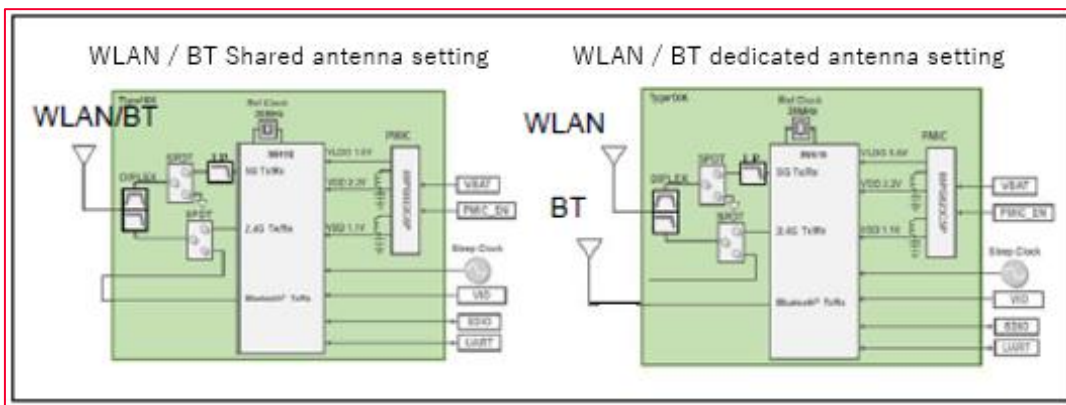

15.3 ISED

Product Description: Communication Module

HVIN: LBEE5CJ1XK and LBEE5CJ2XK

PMN: LBEE5CJ1XK

IC Number: 772C-LB1XK

This module is not sold to general end users directly, therefore, there is no user manual of module. For details about this module, please refer to the specification sheet of module.



1. This module should be installed in the host device according to the interface specification (installation procedure).
2. The OEM integrator has to be aware not to provide information to the end user regarding how to install or remove this RF module in the end user's manual of the end product which integrates this module.

The end user manual shall include all required regulatory information/warning as shown in User manual.

15.3.1 Information to Display on Host Device and User Manual

15.3.1.1 Information on Host Device

The following information must be indicated on the host device of this module.

- Contains IC: 772C-LB1XK
- In case of the final product which can be carried around to outdoor. The following indication is necessary to the final product.



When the STA function is used in channel 52, 54.
 At the time of the channel 52 or 54 setting, please indicate "for indoor use only channel".
 During connecting, please show the channel number which connects.
 And please indicate that the end user may find out "for indoor use only channel".

- If the final product uses the following frequency, please note that there is a limit.

English Version

For indoor use only (5150 – 5250 MHz band and channel 52,54)

French Version

Pour usage intérieur seulement (5150 - 5250 MHz band and channel 52,54)

15.3.1.2 Information in User Manual

The following statements must be described on the user manual of the host device of this module.

English Version

This device complies with Industry Canada's applicable license-exempt RSSs. Operation is subject to the following two conditions:

- This device may not cause interference; and
- This device must accept any interference, including interference that may cause undesired operation of the device.

<p>French Version</p> <p>Le présent appareil est conforme aux CNR d'Industrie Canada applicables aux appareils radio exempts de licence. L'exploitation est autorisée aux deux conditions suivantes:</p> <ul style="list-style-type: none"> • l'appareil ne doit pas produire de brouillage. • l'utilisateur de l'appareil doit accepter tout brouillage radioélectrique subi, même si le brouillage est susceptible d'en compromettre le fonctionnement.
<p>English Version</p> <p>Data transmission is always initiated by software, which is the passed down through the MAC, through the digital and analog baseband, and finally to the RF chip. Several special packets are initiated by the MAC. These are the only ways the digital baseband portion will turn on the RF transmitter, which it then turns off at the end of the packet. Therefore, the transmitter will be on only while one of the aforementioned packets is being transmitted. In other words, this device automatically discontinues transmission in case of either absence of information to transmit or operational failure.</p>
<p>French Version</p> <p>La transmission des données est toujours initiée par le logiciel, puis les données sont transmises par l'intermédiaire du MAC, par la bande de base numérique et analogique et, enfin, à la puce RF. Plusieurs paquets spéciaux sont initiés par le MAC. Ce sont les seuls moyens pour qu'une partie de la bande de base numérique active l'émetteur RF, puis désactive celui-ci à la fin du paquet. En conséquence, l'émetteur reste uniquement activé lors de la transmission d'un des paquets susmentionnés. En d'autres termes, ce dispositif interrompt automatiquement toute transmission en cas d'absence d'information à transmettre ou de défaillance.</p>

	<p>If it is difficult to describe these statements on the host product due to the size, please describe them in the User's manual.</p>
---	--

15.3.2 Antenna Installation in End Product

If the antenna of the end product is removed, please describe the following warning on the manual of the end product which contains this module.

<p>English Version</p> <p>This radio transmitter (772C-LB1XK) has been approved by Innovation, Science and Economic Development Canada to operate with the antenna types listed below, with the maximum permissible gain indicated. Antenna types not included in this list that have a gain greater than the maximum gain indicated for any type listed are strictly prohibited for use with this device.</p>	
Dipole Antenna	Gain: 3.2 dBi@2.4 GHz/4.25 dBi@5 GHz
Dipole Antenna	Gain: 3.4 dBi@2.4 GHz/4.75 dBi@5 GHz
Monopole Antenna	Gain: 3.6 dBi@2.4 GHz/4.6 dBi@5 GHz
<p>French Version</p> <p>Le présent émetteur radio (772C-LB1XK) a été approuvé par Innovation, Sciences et Développement économique Canada pour fonctionner avec les types d'antenne énumérés ci dessous et ayant un gain admissible maximal. Les types d'antenne non inclus dans cette liste, et dont le gain est supérieur au gain maximal indiqué pour tout type figurant sur la liste, sont strictement interdits pour l'exploitation de l'émetteur.</p>	
Dipole Antenna	Gain: 3.2 dBi@2.4 GHz/4.25 dBi@5 GHz
Dipole Antenna	Gain: 3.4 dBi@2.4 GHz/4.75 dBi@5 GHz
Monopole Antenna	Gain: 3.6 dBi@2.4 GHz/4.6 dBi@5 GHz

15.3.3 Equipment Installation for ISED

There are two types of installation for host device.

15.3.3.1 Portable Equipment

Equipment for which the spaces between human body and antenna are used within 20 cm.



It is necessary to take a SAR test with your set mounting this module. Class IV permissive change application is necessary using the SAR report. Please contact Murata.

15.3.3.2 Mobile Equipment

Equipment used at position in which the spaces between human body and antenna exceeded 20 cm.

English Version

This equipment complies with IC radiation exposure limits set forth for an uncontrolled environment and meets RSS-102 of the IC radio frequency (RF) Exposure rules. This equipment should be installed and operated keeping the radiator at least 20 cm or more away from person's body.

French Version

Cet équipement est conforme aux limites d'exposition aux rayonnements énoncées pour un environnement non contrôlé et respecte les règles d'exposition aux fréquences radioélectriques (RF) CNR-102 de l'IC. Cet équipement doit être installé et utilisé en gardant une distance de 20 cm ou plus entre le radiateur et le corps humain.

15.3.4 Power Level for ISED

Table 65 and **Table 66** shows the per antenna port power table for 2.4 GHz for WLAN and Bluetooth. **Table 67** shows the per antenna port power table for 5 GHz WLAN.

Table 65: ISED Power Level 2.4 GHz WLAN Per Antenna Port

Mode	Rate	Channel	Maximum Tune Up Tolerance [dBm]
IEEE 802.11b	All Rates	1 ~ 11	17.0 ± 2.0
IEEE 802.11g	All Rates	1 ~ 3, 9 ~ 11	14.0 ± 2.0
	6 Mbps, 9 Mbps, 12 Mbps, 18 Mbps	4 ~ 8	17.0 ± 2.0
	24 Mbps, 36 Mbps, 48 Mbps, 54 Mbps	4 ~ 8	16.0 ± 2.0
IEEE 802.11n (HT20)	All Rates	1 ~ 3, 9 ~ 11	13.0 ± 2.0
	MCS0, MCS1, MCS2	4 ~ 8	16.0 ± 2.0
	MCS3, MCS 4, MCS 5, MCS 6, MCS7	4 ~ 8	15.0 ± 2.0

Table 66: ISED Power Level 2.4 GHz BT/BLE Per Antenna Port

Mode	Maximum Tune Up Tolerance [dBm]	
	Shared BT Antenna (PIN No. 45)	Dedicated BT Antenna (PIN No. 47)
BR	3.0 ± 3.0	3.3 ± 3.0
EDR	0.0 ± 3.0	0.3 ± 3.0
LE	3.0 ± 3.0	3.3 ± 3.0

Mode	Maximum Tune Up Tolerance [dBm]	
	Shared BT Antenna (PIN No. 45)	Dedicated BT Antenna (PIN No. 47)
LE 2 Mbps	3.0 ± 3.0	3.3 ± 3.0
LE (Long Range) 125 kbps	3.0 ± 3.0	3.3 ± 3.0
LE (Long Range) 500 kbps	3.0 ± 3.0	3.3 ± 3.0

Table 67: ISED Power Level 5 GHz Per Antenna Port

Mode	Rate	Band	Channel	Maximum Tune Up Tolerance [dBm]
IEEE 802.11a	All Rates	W52/W53	36 ~ 48	14.0 ± 2.0
	All Rates	W52/W53	52 ~ 60	16.0 ± 2.0
	All Rates	W53	64	14.0 ± 2.0
	All Rates	W56	100, 144	14.0 ± 2.0
	All Rates	W56	104 ~ 116, 132 ~ 140	15.0 ± 2.0
	All Rates	W58	149 ~ 165	15.0 ± 2.0
IEEE 802.11n (HT20)	All Rates	W52/W53	36, 64	13.0 ± 2.0
	All Rates	W52	40 ~ 48	14.0 ± 2.0
	All Rates	W53	52 ~ 60	15.0 ± 2.0
	All Rates	W56	100, 144	13.0 ± 2.0
	All Rates	W56	104 ~ 116, 132 ~ 140	14.0 ± 2.0
	All Rates	W58	149 ~ 165	14.0 ± 2.0
IEEE 802.11n (HT40)	All Rates	W52/W53	38, 62	12.0 ± 2.0
	All Rates	W52/W53	46, 54	14.0 ± 2.0
	All Rates	W56	102, 142	12.0 ± 2.0
	All Rates	W56	110, 134	14.0 ± 2.0
	All Rates	W58	151, 159	14.0 ± 2.0

15.3.5 Theory of Operation for ISED

Table 68 shows the theory of operation for WLAN and **Table 69** shows theory of operation for Bluetooth/LE.

Table 68: ISED Theory of Operation for WLAN

Frequency of Operation			Scan	Ad-hoc mode
2.4 GHz	11b/g/n (HT20)	2412 - 2462 MHz	Active	Yes
W52	11a/n (HT20)	5180 - 5240 MHz	Active	Yes
	11n (HT40)	5190 - 5230 MHz	Active	Yes
W53	11a/n (HT20)	5260 - 5320 MHz	Passive	No
	11n (HT40)	5270 - 5310 MHz	Passive	No
W56	11a/n (HT20)	5500 - 5720 MHz	Passive	No
	11n (HT40)	5510 - 5710 MHz	Passive	No
W58	11a/n (HT20)	5745 - 5825 MHz	Active	Yes
	11n (HT40)	5755 - 5795 MHz	Active	Yes



The frequency band 5600 MHz – 5640 MHz (11 a/n 20M band), 5590 MHz-5630 MHz (11n 40M band) is restricted in ISED.
 DFS MASTER function not available.
 DFS client function available.
 There is a TPC function.

Table 69: ISED Theory of Operation for Bluetooth

Frequency of Operation		Scan	Ad-hoc mode
BT	BR	2402 ~ 2480 MHz	N/A
	EDR	2402 ~ 2480 MHz	N/A
LE	LE	2402 ~ 2480 MHz	N/A
	LE 2 Mbps	2402 ~ 2480 MHz	N/A
	LE (Long Range) 125 kbps	2402 ~ 2480 MHz	N/A
	LE (Long Range) 500 kbps	2402 ~ 2480 MHz	N/A

15.4 Europe



Precautions when using report number
 E2/2021/30010 ~ E2/2021/30015 (RF Conducted test result only) for final product DoC.

15.4.1 Power Level for Europe

Table 70 and **Table 71** shows the per antenna port power table for 2.4 GHz for WLAN and Bluetooth. **Table 72** shows the per antenna port power table for 5 GHz WLAN.

Table 70: Europe Power Level 2.4 GHz Per Antenna Port

Mode	Rate	Channel	Maximum Tune Up Tolerance [dBm]
IEEE 802.11b	All Rates	1 ~ 13	14.0 ± 2.0
IEEE 802.11g	All Rates	1 ~ 13	14.0 ± 2.0
IEEE 802.11n (HT20)	All Rates	1 ~ 13	14.0 ± 2.0

Table 71: Europe Power Level 2.4 GHz BT/BLE Per Antenna Port

Mode	Maximum Tune Up Tolerance [dBm]	
	Shared BT Antenna (PIN No. 45)	Dedicated BT Antenna (PIN No. 47)
BR	3.0 ± 3.0	3.3 ± 3.0
EDR	0.0 ± 3.0	0.3 ± 3.0
LE	3.0 ± 3.0	3.3 ± 3.0
LE 2 Mbps	3.0 ± 3.0	3.3 ± 3.0
LE (Long Range) 125 kbps	3.0 ± 3.0	3.3 ± 3.0
LE (Long Range) 500 kbps	3.0 ± 3.0	3.3 ± 3.0

Table 72: Europe Power Level 5 GHz Per Antenna Port

Mode	Rate	Band	Channel	Maximum Tune Up Tolerance [dBm]
IEEE 802.11a	All Rates	W52/W53/W56	36 ~ 140	15.0 ± 2.0
	All Rates	W58	149 ~165	7.0 ± 2.0
IEEE 802.11n (HT20)	All Rates	W52/W53/W56	36 ~ 140	14.0 ± 2.0
	All Rates	W58	149 ~165	7.0 ± 2.0
IEEE 802.11n (HT40)	All Rates	W52/W53/W56	38 ~ 134	14.0 ± 2.0
	All Rates	W58	151, 159	7.0 ± 2.0

15.4.2 Theory of Operation for Europe

Table 73 shows the theory of operation for WLAN and **Table 74** shows theory of operation for Bluetooth/LE.

Table 73: Europe Theory Operation for WLAN

Frequency of Operation			Scan	Ad-hoc mode
2.4 GHz	11b/g/n (HT20)	2412 - 2472 MHz	Active	Yes
W52	11a/n (HT20)	5180 - 5240 MHz	Active	Yes
	11n (HT40)	5190 - 5230 MHz	Active	Yes
W53	11a/n (HT20)	5260 - 5320 MHz	Passive	No
	11n (HT40)	5270 - 5310 MHz	Passive	No
W56	11a/n (HT20)	5500 - 5700 MHz	Passive	No
	11n (HT40)	5510 - 5670 MHz	Passive	No
W58	11a/n (HT20)	5745 - 5825 MHz	Active	Yes
	11n (HT40)	5755 - 5795 MHz	Active	Yes



DFS MASTER function not available.
 DFS client function available.
 There is a TPC function.

Table 74: Europe Theory Operation for Bluetooth

Frequency of Operation			Scan	Ad-hoc mode
BT	BR	2402 ~ 2480 MHz	N/A	N/A
	EDR	2402 ~ 2480 MHz	N/A	N/A
LE	LE	2402 ~ 2480 MHz	N/A	N/A
	LE 2 Mbps	2402 ~ 2480 MHz	N/A	N/A
	LE (Long Range) 125 kbps	2402 ~ 2480 MHz	N/A	N/A
	LE (Long Range) 500 kbps	2402 ~ 2480 MHz	N/A	N/A

16 Tape and Reel Packing

This section provides the general specifications for tape and reel packing.

16.1 Dimensions of Tape (Plastic Tape)

Figure 28 is a graphical representation of the tape dimension (plastic tape)¹⁰

Figure 28: Dimensions of Tape (Unit: mm)

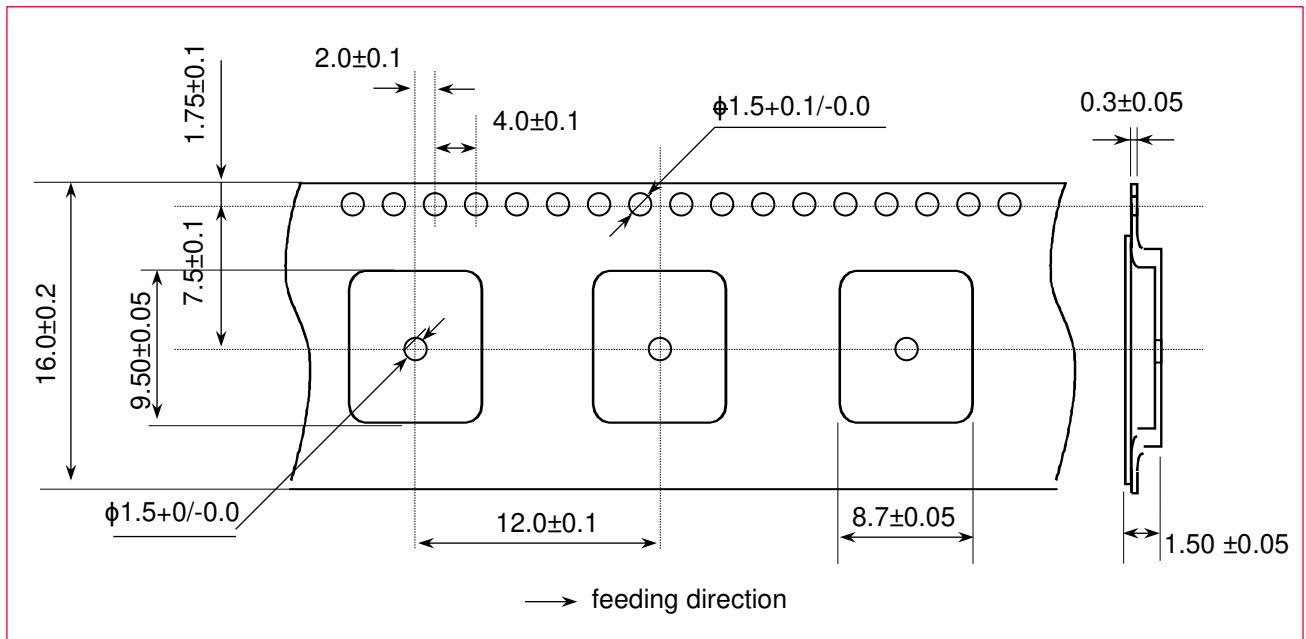

¹⁰ Cumulative tolerance of maximum 40 +/- 0.15 mm for every 10 pitches.

16.2 Dimension of Reel

Figure 29 shows the reel dimensions.

Figure 29: Dimensions of Reel (Unit: mm)

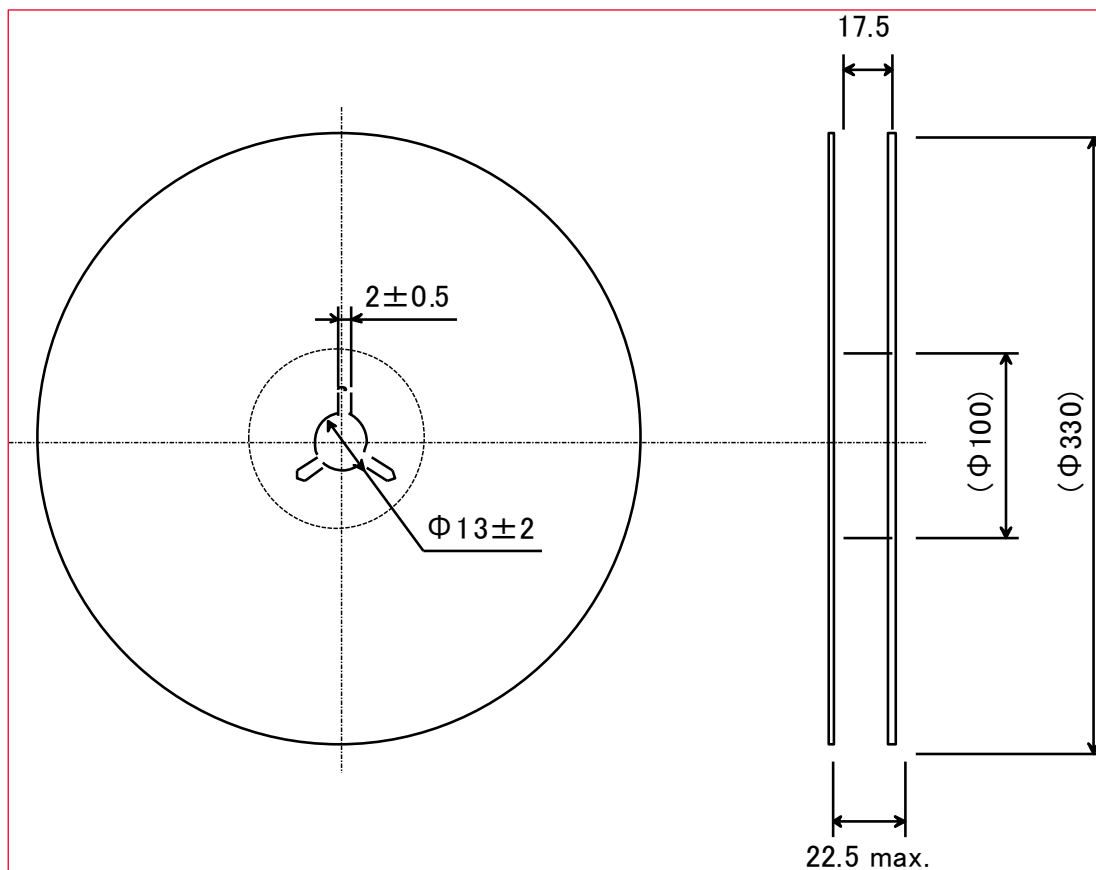

16.3 Taping Diagrams

Figure 30 shows the tapings diagrams.

Figure 30: Taping Diagrams

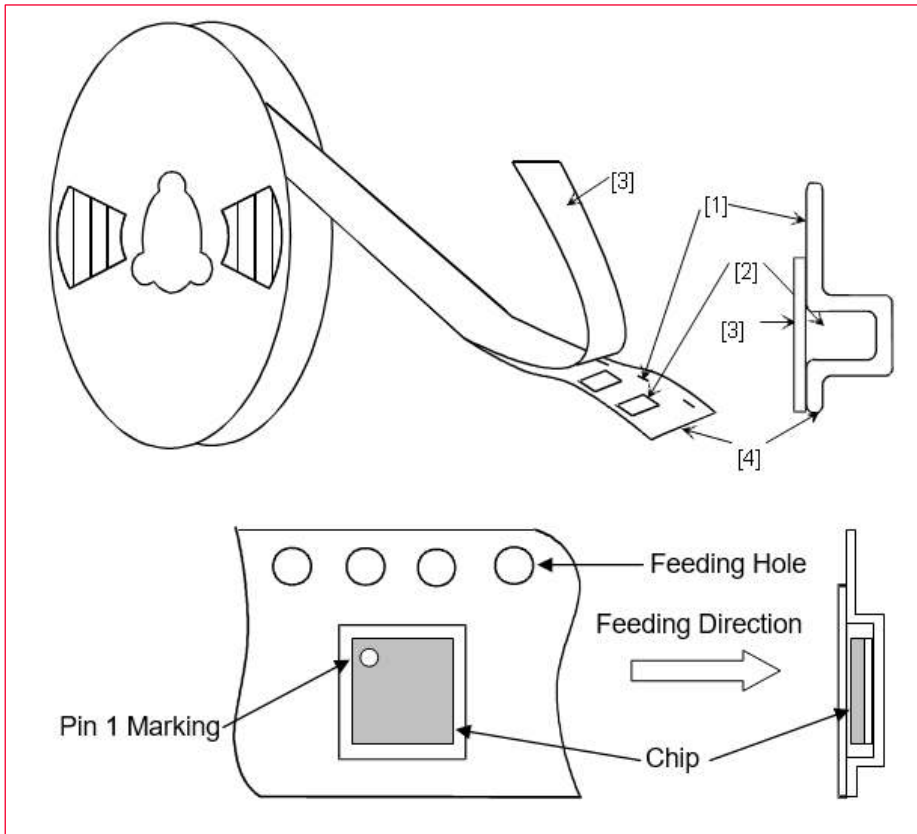

Table 75: Taping Specifications

Mark	Description
1	Feeding Hole. As specified in Dimensions of Tape (Plastic tape) ☞
2	Hole for chip. As specified in Dimensions of Tape (Plastic tape) ☞
3	Cover tape. 62 μm in thickness.
4	Base tape. As specified in Dimensions of Tape (Plastic tape) ☞

16.4 Leader and Tail Tape

The leader and tail tape are shown in **Figure 31**.

Figure 31: Leader and Tail Tape

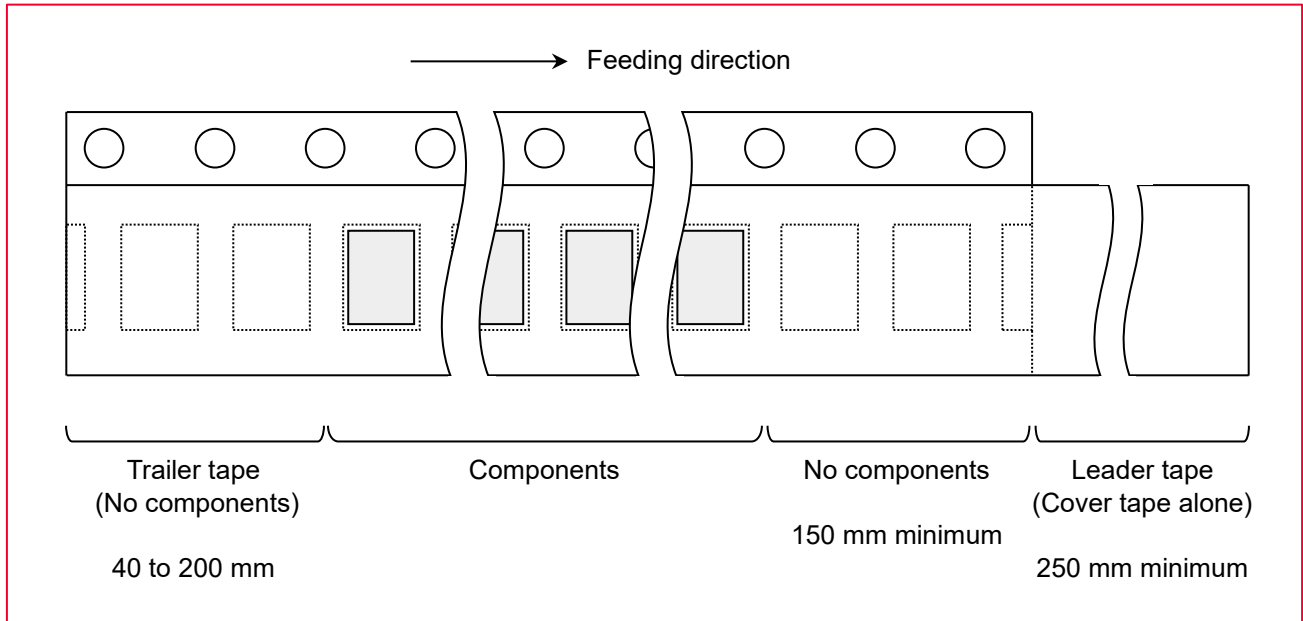

- The tape for chips is wound clockwise, the feeding holes to the right side as the tape is pulled toward the user.
- The cover tape and base tape are not adhered at no components area for 250 mm minimum.
- Tear off strength against pulling of cover tape: 5 N minimum.
- Packaging unit: 1000 pcs. / Reel
- Tape material:
 - Base tape: Plastic
 - Reel: Plastic
 - Cover tape, cavity tape and reel are made the anti-static processing.
- Peeling off force: 1.1 N maximum in the direction of peeling as shown in **Figure 32**.

Figure 32: Peeling Force

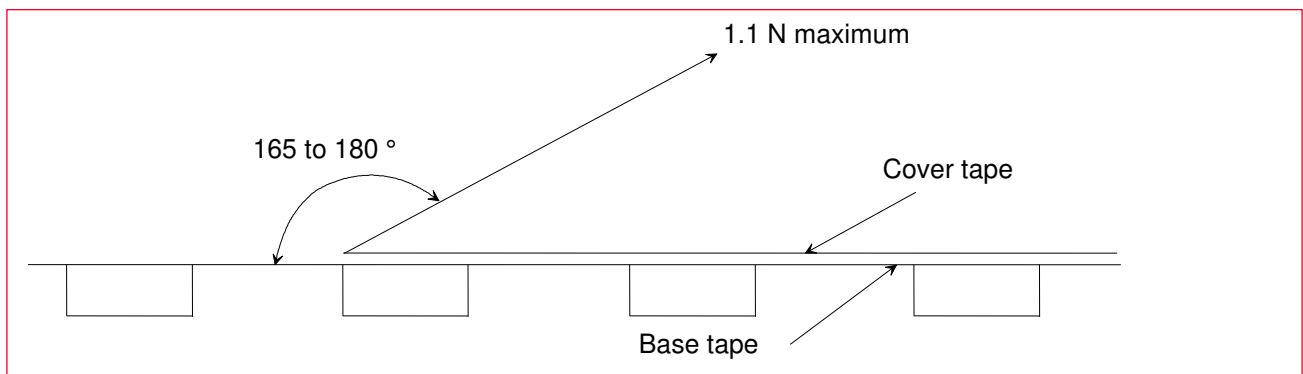

16.5 Packaging (Humidity Proof Packing)

Figure 33 shows the humidity proof Packaging.

Figure 33: Humidity Proof Packaging

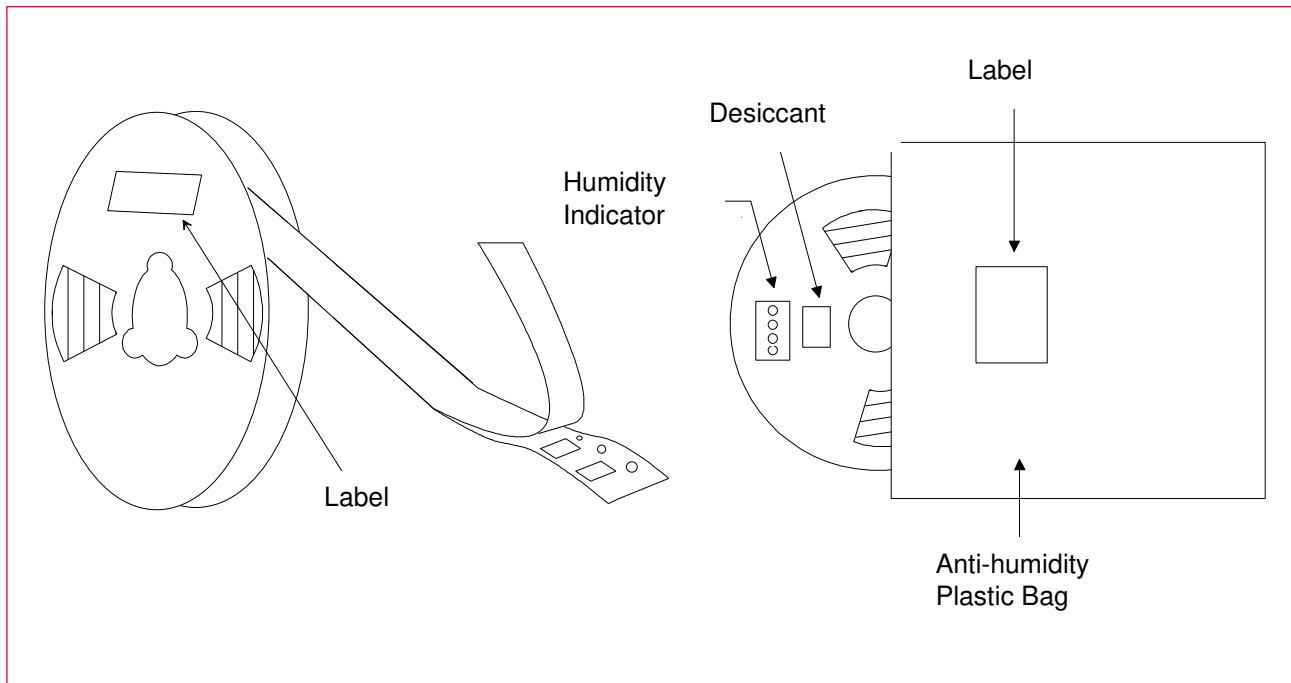

Tape and reel must be sealed with the anti-humidity plastic bag. The bag contains the desiccant and the humidity indicator.

17 Notice

17.1 Storage Conditions

- Please use this product within 6 months after receipt.
- The product shall be stored without opening the packing under the ambient temperature from 5 to 35 °C and humidity from 20 ~ 70 %RH (Packing materials may be deformed at the temperature over 40 °C).
- The product left more than 6 months after reception; the solderability needs to be confirmed before it is used.
- The product shall be stored in non-corrosive gas (Cl₂, NH₃, SO₂, NO_x, etc.).
- Any excess mechanical shock including, but not limited to, sticking the packing materials by sharp object, and dropping the product, shall not be applied in order not to damage the packing materials.
- This product is applicable to MSL3 (Based on IPC/JEDEC J-STD-020)
 - After the packing opened, the product shall be stored at <30 °C / <60 %RH and the product shall be used within 168 hours.
 - When the color of the indicator in the packing changed, the product shall be baked before soldering.
- Baking condition: 125 +5/-0 °C, 24 hours, 1 time
- The products shall be baked on the heat-resistant tray because the material (Base Tape, Reel Tape and Cover Tape) is not heat-resistant.

17.2 Handling Conditions

- Be careful in handling or transporting products because excessive stress or mechanical shock may break products.
- Handle with care if products may have cracks or damages on their terminals, the characteristics of products may change. Do not touch products with bare hands that may result in poor solder ability and destroy by static electrical charge.

17.3 Standard PCB Design (Land Pattern and Dimensions):

- All the ground terminals should be connected to the ground patterns. Furthermore, the ground pattern should be provided between IN and OUT terminals. Please refer to the specifications for the standard land dimensions.
- The recommended land pattern and dimensions is as Murata's standard. The characteristics of products may vary depending on the pattern drawing method, grounding method, land dimensions, land forming method of the NC terminals and the PCB material and thickness. Therefore, be sure to verify the characteristics in the actual set. When using non-standard lands, contact Murata beforehand.

17.4 Notice for Chip Placer

When placing products on the PCB, products may be stressed and broken by uneven forces from a worn-out chucking locating claw or a suction nozzle. To prevent products from damages, be sure to follow the specifications for the maintenance of the chip placer being used. For the positioning of products on the PCB, be aware that mechanical chucking may damage products.

17.5 Soldering Conditions

The recommendation conditions of soldering are shown in **Figure 34**.

Soldering must be carried out by the above-mentioned conditions to prevent products from damage. Set up the highest temperature of reflow within 260 °C. Contact Murata before use if concerning other soldering conditions.

Figure 34: Reflow Soldering Standard Conditions (Example)

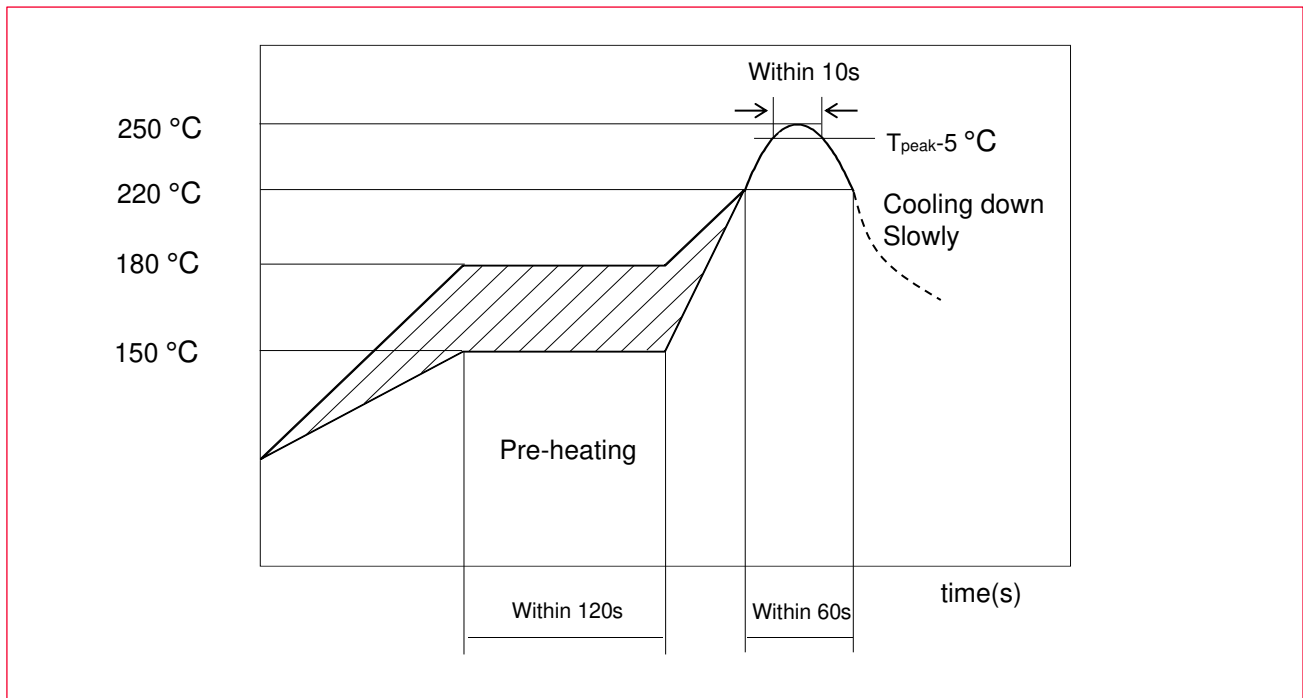

Please use the reflow within 2 times.

Use rosin type flux or weakly active flux with a chlorine content of 0.2 wt. % or less.

17.6 Cleaning

This product is moisture sensitive; therefore, any cleaning is not recommended. If any cleaning process is done the customer is responsible for any issues or failures caused by the cleaning process.

17.7 Operational Environment Conditions

Products are designed to work for electronic products under normal environmental conditions (ambient temperature, humidity and pressure). Therefore, products have no problems to be used under the similar conditions to the above-mentioned. However, if products are used under the following circumstances, it may damage products and leakage of electricity and abnormal temperature may occur.

- In an atmosphere containing corrosive gas (Cl₂, NH₃, SO_x, NO_x etc.).
- In an atmosphere containing combustible and volatile gases.
- Dusty place.
- Direct sunlight place.
- Water splashing place.
- Humid place where water condenses.
- Freezing place.



If there are possibilities for products to be used under the preceding clause, consult with Murata before actual use.



Do not apply static electricity or excessive voltage while assembling and measuring, as it might be a cause of degradation or destruction to apply static electricity to products.

18 Preconditions to Use Our Products



PLEASE READ THIS NOTICE BEFORE USING OUR PRODUCTS.

Please make sure that your product has been evaluated and confirmed from the aspect of the fitness for the specifications of our product when our product is mounted to your product.

All the items and parameters in this product specification/datasheet/catalog have been prescribed on the premise that our product is used for the purpose, under the condition and in the environment specified in this specification. You are requested not to use our product deviating from the condition and the environment specified in this specification.

Please note that the only warranty that we provide regarding the products is its conformance to the specifications provided herein. Accordingly, we shall not be responsible for any defects in products or equipment incorporating such products, which are caused under the conditions other than those specified in this specification.

WE HEREBY DISCLAIM ALL OTHER WARRANTIES REGARDING THE PRODUCTS, EXPRESS OR IMPLIED, INCLUDING WITHOUT LIMITATION ANY WARRANTY OF FITNESS FOR A PARTICULAR PURPOSE, THAT THEY ARE DEFECT-FREE, OR AGAINST INFRINGEMENT OF INTELLECTUAL PROPERTY RIGHTS.

You agree that you will use any and all software or program code (including but not limited to hcd, firmware, nvram, and blob) we may provide or to be embedded into our product ("Software") provided that you use the Software bundled with our product. YOU AGREE THAT THE SOFTWARE SHALL BE PROVIDED TO YOU "AS IS" BASIS, MURATA MAKES NO REPRESENTATIONS OR WARRANTIES THAT THE SOFTWARE IS ERROR-FREE OR WILL OPERATE WITHOUT INTERRUPTION. AND MORE, MURATA MAKES NO REPRESENTATIONS OR WARRANTIES OF ANY KIND WHETHER EXPRESS OR IMPLIED WITH RESPECT TO THE SOFTWARE. MURATA EXPRESSLY DISCLAIM ANY AND ALL WARRANTIES OR CONDITIONS OF MERCHANTABILITY, FITNESS FOR A PARTICULAR PURPOSE NOR THE WARRANTY OF TITLE OR NON-INFRINGEMENT OF INTELLECTUAL PROPERTY RIGHTS.

You shall indemnify and hold harmless us, our affiliates, and our licensor from and against any and all claims, costs, expenses and liabilities (including attorney's fees), which arise in connection with the using the Software.

The product shall not be used in any application listed below which requires especially high reliability for the prevention of such defect as may directly cause damage to the third party's life, body or property. You acknowledge and agree that, if you use our products in such applications, we will not be responsible for any failure to meet such requirements. Furthermore, YOU AGREE TO INDEMNIFY AND DEFEND US AND OUR AFFILIATES AGAINST ALL CLAIMS, DAMAGES, COSTS, AND EXPENSES THAT MAY BE INCURRED, INCLUDING WITHOUT LIMITATION, ATTORNEY FEES AND COSTS, DUE TO THE USE OF OUR PRODUCTS AND THE SOFTWARE IN SUCH APPLICATIONS.

- Aircraft equipment.
- Aerospace equipment.
- Undersea equipment.
- Power plant control equipment.
- Medical equipment.
- Traffic signal equipment.

- Burning / explosion control equipment.
- Disaster prevention / crime prevention equipment.
- Transportation equipment (vehicles, trains, ships, elevator, etc.).
- Application of similar complexity and/ or reliability requirements to the applications listed in the above.

We expressly prohibit you from analyzing, breaking, reverse-engineering, remodeling altering, and reproducing our product. Our product cannot be used for the product which is prohibited from being manufactured, used, and sold by the regulations and laws in the world.

We do not warrant or represent that any license, either express or implied, is granted under any our patent right, copyright, mask work right, or our other intellectual property right relating to any combination, machine, or process in which our products or services are used. Information provided by us regarding third-party products or services does not constitute a license from us to use such products or services or a warranty or endorsement thereof. Use of such information may require a license from a third party under the patents or other intellectual property of the third party, or a license from us under our patents or other intellectual property.

Please do not use our products, our technical information and other data provided by us for the purpose of developing of mass-destruction weapons and the purpose of military use.

Moreover, you must comply with "foreign exchange and foreign trade law", the "U.S. export administration regulations", etc.

Please note that we may discontinue the manufacture of our products, due to reasons such as end of supply of materials and/or components from our suppliers.

By signing on specification sheet or approval sheet, you acknowledge that you are the legal representative for your company and that you understand and accept the validity of the contents herein. When you are not able to return the signed version of specification sheet or approval sheet within 30 days from receiving date of specification sheet or approval sheet, it shall be deemed to be your consent on the content of specification sheet or approval sheet. Customer acknowledges that engineering samples may deviate from specifications and may contain defects due to their development status. We reject any liability or product warranty for engineering samples. In particular we disclaim liability for damages caused by

- The use of the engineering sample other than for evaluation purposes, particularly the installation or integration in the product to be sold by you,
- Deviation or lapse in function of engineering sample,
- Improper use of engineering samples.

We disclaim any liability for consequential and incidental damages.

If you can't agree with the above contents, please contact sales.

Revision History

Revision Code	Date	Changed Item	Comment
	2020.12.16	First Issue	
A	2021.03.23	Top page 4. Block Diagram 9. Operating Conditions 11.2 High-speed UART specifications 12. DC/RF Characteristics	<ul style="list-style-type: none"> Removed "ac" Updated Updated operating temperature. Added default baud rate information. Added 802.11n 40 MHz in 2.4 GHz. Added Tx power values.
B	2021.03.31	14. Reference Circuit 15. Tape and Reel Packing	<ul style="list-style-type: none"> Added circuit for dedicated BT antenna. Added
C	2021.04.05	2. Key feature & 5.2 Bluetooth Qualification 7.1 Pin Assignments 7.2 Pin Descriptions	<ul style="list-style-type: none"> Added a comment on supported Bluetooth functions Corrected pin number Corrected pin number
D	2021.04.14	14. Reference Circuit	<ul style="list-style-type: none"> Corrected circuit for dedicated BT antenna
E	2021.05.19	2. Key Features 7.5 Pin States 14. Reference Circuit 12.8 DC/RF Characteristics for Bluetooth 12.9 DC/RF Characteristics for Bluetooth Low Energy	<ul style="list-style-type: none"> Added Weight Added Internal pull values Corrected circuit for Shard BT antenna Updated Output Power Updated Output Power
F	2021.06.10	12. DC/RF Characteristics	<ul style="list-style-type: none"> Delete 802.11n 40 MHz in 2.4 GHz.
G	2021.07.30	5. Certification Information 9. Operating Conditions 14. Reference Circuit	<ul style="list-style-type: none"> Added Certification Information Added DC current Removed dedicated BT antenna
H	2021.09.15	13. Land patterns	<ul style="list-style-type: none"> Updated figure
I	2021.10.14	3. Ordering Information 7. Module Pin Descriptions 12. DC / RF Characteristics 14. Reference Circuit	<ul style="list-style-type: none"> Added part number for MP Updated description of GPIOs and WCI IF Corrected values of Wi-Fi Current consumption. Corrected typo
J	2021.11.19	11.1.2 High Speed Mode 15. Tape and Reel Packing	<ul style="list-style-type: none"> Corrected the note on SDIO 2.0 mode. Corrected Dimensions of Tape
K	2021.11.25	6. Dimensions, Marking and Terminal Configurations	<ul style="list-style-type: none"> Corrected Dimensions <ul style="list-style-type: none"> a) e1: 0.38 → 0.375 b) e3: 0.48 → 0.475
L	2021.12.14	7.2 Pin Descriptions 7.4 Pin States 9.1 Operating Conditions 9.2 External Sleep Clock Requirements 10. Power Sequence 14. Reference Circuit	<ul style="list-style-type: none"> Added comments to pin 10 Added SLP_CLK_IN, WCI-2_SIN and WCI-2_SOUT. Defined IO current and Peak current Added a comment Defined timing parameters Pull-down RF_CNTL2_N and updated descriptions.
M	2022.02.01	7.2 Pin Descriptions 7.3 Configuration Pins	<ul style="list-style-type: none"> Revised typo about the description in #52:GPIO[0]. Added Description for configuration pins

Revision Code	Date	Changed Item	Comment
N	2022.04.19	9.1 Operating Conditions 9.4 Package Thermal Conditions 12.7 DC/RF Characteristics for Bluetooth 12.8 DC/RF Characteristics for Bluetooth	<ul style="list-style-type: none"> Defined Ta and Tj. Added Added test method Added test method
O	2022.04.27	14. Reference Circuit	<ul style="list-style-type: none"> Corrected Typo
P	2022.07.01	7.2 Pin Descriptions 7.3 Configuration Pins 14. Reference Circuit Appendix	<ul style="list-style-type: none"> Corrected GPIO[0], Deleted JTAG Added Description for configuration pins Corrected typo (P.22 VBAT) Translated Japanese to English Corrected diagram C
Q	2022.12.02	2. Key Features 10. Power Sequence 12. DC/RF Characteristics	<ul style="list-style-type: none"> Added fit Added 10.2.2 host power off pin (PMIC_EN) usage Corrected Wi-Fi 11a/b/g/n DC current Tx power
R	2023.01.13	2. Key Features 3. Ordering Information 6. Dimensions, Markings and Terminal Configurations 7.4 Pin States 14. Reference Circuit Appendix	<ul style="list-style-type: none"> Added more information Added Embedded Artists' M.2 module information. Added Identification mark Added comment about termination of open pins. Moved section to HW app note. Moved antenna sections to HW app note. Moved Appendix information into Sections 14 and 15. <p>Updated to new format</p>



Copyright © Murata Manufacturing Co., Ltd. All rights reserved. The information and content in this document are provided “as-is” with no warranties of any kind and are for informational purpose only. Data and information have been carefully checked and are believed to be accurate; however, no liability or responsibility for any errors, omissions, or inaccuracies is assumed.

Wi-Fi® is a registered trademark of Wi-Fi Alliance. The Bluetooth® word mark and logos are registered trademarks owned by Bluetooth SIG, Inc. Other brand and product names are trademarks or registered trademarks of their respective owners.

Specifications are subject to change without notice.