

REV.	DATE	ECR NO.	DESCRIPTION
NC	11/17/08	-	INITIAL RELEASE

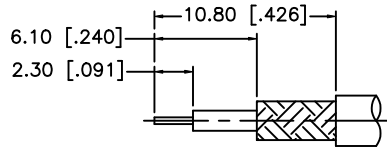

RECOMMENDED CABLE STRIPPING DIMENSIONS

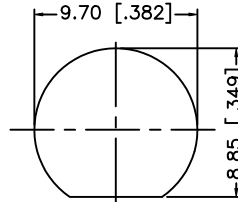
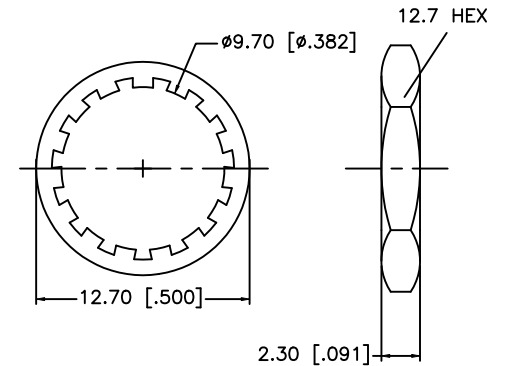
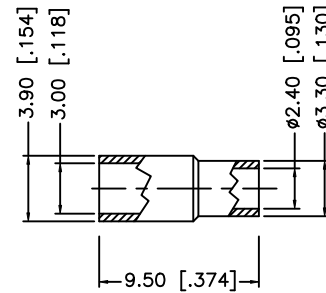
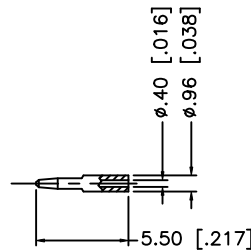
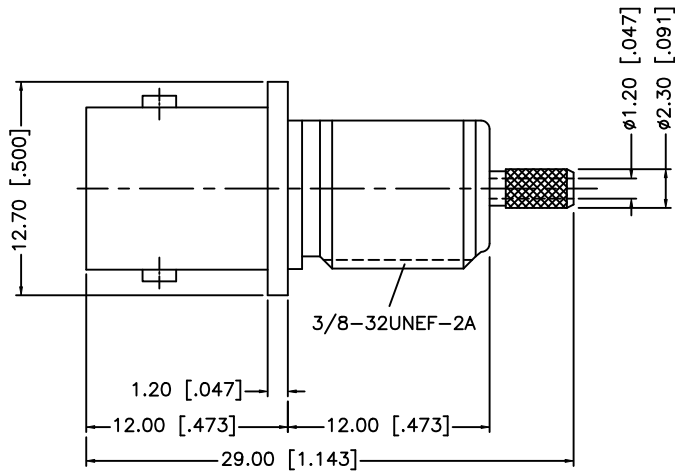

RECOMMENDED MOUNTING HOLE

NOTES:

1. CRIMPED FERRULE HEX CRIMP SIZE .128" [3.25]
2. CRIMPED CONTACT PIN SQ. CRIMP SIZE .027" [0.70]

DESCRIPTION	MATERIAL	FINISH	QTY
8			
7			
6	HEX NUT	BRASS	NICKEL 1
5	LOCK WASHER	BRASS	NICKEL 1
4	FERRULE	BRASS	NICKEL 1
3	CONTACT PIN	PHOS. BRONZE	GOLD 1
2	INSULATOR	PTFE	NATURAL 1
1	BODY	BRASS	NICKEL 1

UNLESS OTHERWISE SPECIFIED DIMENSIONS ARE IN MILLIMETERS. DIMENSIONS IN [ ] ARE IN INCHES AND FOR CUSTOMER REFERENCE ONLY.

UNLESS OTHERWISE SPECIFIED TOLERANCES FOR MILLIMETERS ARE:  
0.5 - 8mm ± 0.20mm  
8 - 30mm ± 0.40mm  
30 - 120mm ± 0.50mm

UNLESS OTHERWISE SPECIFIED TOLERANCES FOR INCHES ARE:  
.020 - .315 = ± 0.007"  
.315 - 1.180 = ± 0.015"  
1.180 - 4.724 = ± 0.020"

DO NOT SCALE DRAWING

APPROVALS	DATE
DRAWN GRS	11/17/08
CHECKED	
ISSUED	
SHEET 1 OF 1	
CAD FILE	C:/112/112757.DWG

<h1>Amphenol Connex</h1>				
PART DESCRIPTION				
<b>BNC BULKHEAD CRIMP JACK – FRONT MOUNT (FOR RG-196A/U CABLE)</b>				
PART NO.				
<b>112757</b>				
DWG. NO.	112757.DWG	REV.	NC	SCALE NA