

REVISIONS			
REV	ECN, ERN NO.	DATE	APPRD.
B	PRODUCT DRAWING (EAR 14498)	NOV9/16	K.L.



ORDERING CODE: F C E 1 7 - E O 9 P A - 4 4 E J

**SERIES**  
FCE17=FILTERED D-SUB, RoHS

**SIZE/NUMBER OF CONTACTS**  
E09, A15, B25, OR C37 (SEE NOTE 7)

**CONNECTOR STYLE**  
P=PIN  
S=SOCKET

**TERMINATION TYPE**  
A=.318" [8.08] FOOTPRINT

**MOUNTING**  
2=.120 [3.05] DIA THROUGH HOLE  
3=#4-40 UNC SELF-LOCKING THREAD  
4=#4-40 UNC THREAD  
6=M3 x 0.5 THREAD  
E=CODE 4 MOUNTING WITH #4-40 UNC HEX JACK SOCKETS SUPPLIED.

**GOLD THICKNESS/MAGNETIC PROPERTIES**  
J=15 MICRONS [0.38 MICRONS], GOLD ON MATING AREA, REDUCED MAGNETIC SUSCEPTIBILITY

**MODIFIER**  
E=PLASTIC BRACKET WITHOUT BOARDLOCK

**FILTER CAPACITANCE**  
D=50 pF      5=1000 pF  
B=100 pF     7=1200 pF  
O=180 pF     6=1300 pF  
F=330 pF     J=1500 pF  
L=380 pF     E=2200 pF  
1=470 pF     9=5600 pF  
4=820 pF     8=47000 pF  
                 N=NO FILTERS

REFER TO AMPHENOL CATALOGUE FOR FILTER PERFORMANCE CHARACTERISTICS

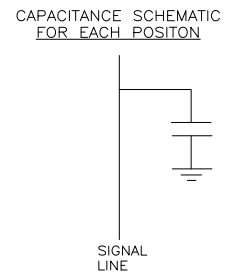
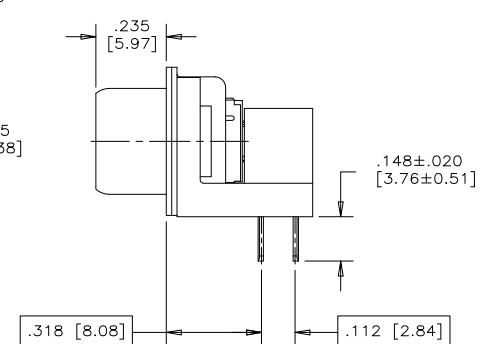
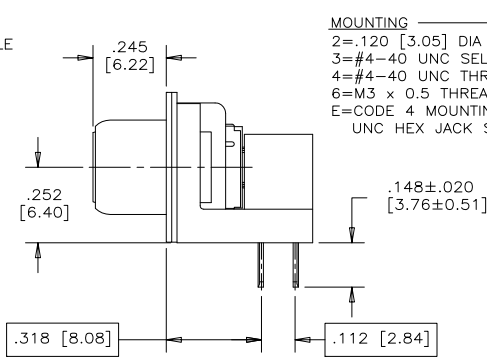
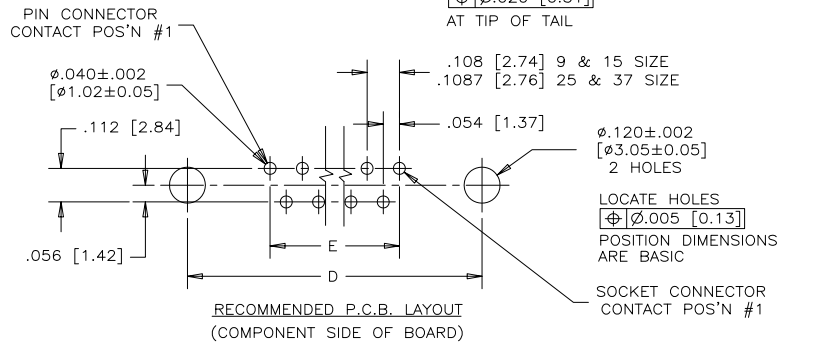
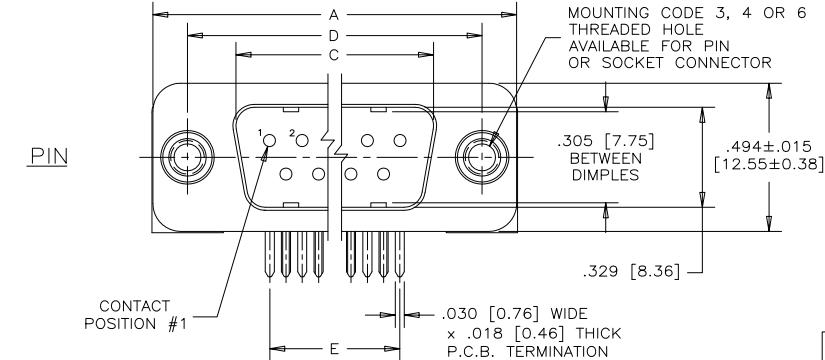
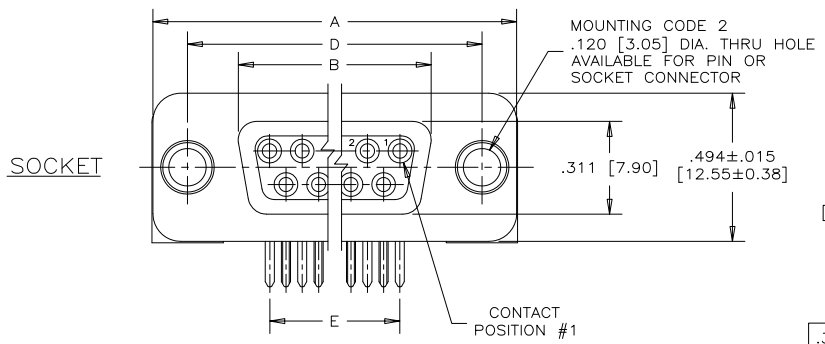
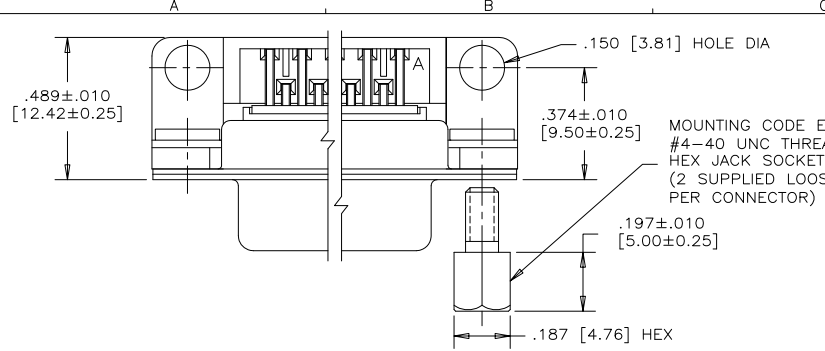

**NOTES:**

- MATERIALS: ALL MATERIALS ARE RoHS COMPLIANT.
  - FRONT SHELL: COPPER ALLOY, TIN PLATED
  - REAR SHELL: STEEL, TIN PLATED
  - CONTACTS: PHOSPHOR BRONZE, PLATED WITH GOLD OVER 50µ" [1.27 MICRONS] MINIMUM NICKEL IN THE MATING AREA AND 100µ" [2.54 MICRONS] MINIMUM MATTE TIN ON THE TAILS.
  - INSULATOR: ENGINEERING THERMOPLASTIC, GLASS REINFORCED, UL FLAMMABILITY RATING 94V-0, COLOUR: BLACK
  - MOUNTING HARDWARE: COPPER ALLOY, TIN OR NICKEL PLATED.
- CONTACT RESISTANCE: 15 MILLIOHMS MAXIMUM
- INSULATION RESISTANCE: 3000 MEGOHMS MINIMUM
- CURRENT RATING: 5 AMPS MAXIMUM
- OPERATING TEMPERATURE: -40°C TO 85°C
- TOLERANCE UNLESS INDICATED OTHERWISE: ±.005 [0.13]
- CONSULT WITH AMPHENOL REGARDING AVAILABILITY OF 37 SIZE CONNECTORS.

SIZE	STYLE	A±.015 [0.38]	B±.005 [0.13]	C±.005 [0.13]	D±.005 [0.13]	E BSC.
E09	PIN	1.213 [30.81]	-----	.666 [16.92]	.984 [24.99]	.432 [10.97]
	SOCKET	-----	.643 [16.33]	-----	-----	-----
A15	PIN	1.541 [39.14]	-----	.994 [25.25]	1.312 [33.32]	.756 [19.20]
	SOCKET	-----	.971 [24.66]	-----	-----	-----
B25	PIN	2.088 [53.04]	-----	1.534 [38.96]	1.852 [47.04]	1.304 [33.12]
	SOCKET	-----	1.511 [38.38]	-----	-----	-----
C37	PIN	2.729 [69.32]	-----	2.182 [55.42]	2.500 [63.50]	1.956 [49.68]
	SOCKET	-----	2.159 [54.84]	-----	-----	-----

DRAWN	M.PAHULJE	DATE	JUL22/15
DESIGNED			
CHECKED	K.LAMBIE	DATE	JUL22/15
I. E. APPRD.			
Q. A. APPRD.			
DWG. APPRD.			
ENG. REL. NO.			
REF.	EAR 14384		
DIMENSIONS ARE IN	INCHES [mm]	CODE ID. NO.	03554

**Amphenol Canada Corp.**

FCE17 SERIES FILTERED D-SUB CONNECTOR, PIN & SOCKET, RIGHT ANGLE, .318[8.08] F/P, PLASTIC MTG. BRACKET WITHOUT BOARDLOCK, REDUCED MAGNETIC SUSCEPTIBILITY, RoHS COMPLIANT

DWG	DRAWING NO.	REV.
C	P-FCE17-XXXXA-XXEJ	B
SCALE	3/1	WT. -----
SURF.	-----	SHEET 1 of 1

THIS DOCUMENT CONTAINS PROPRIETARY INFORMATION AND SUCH INFORMATION MAY NOT BE DISCLOSED TO OTHERS FOR ANY PURPOSE OR USED FOR MANUFACTURING PURPOSES WITHOUT WRITTEN PERMISSION FROM AMPHENOL CANADA CORP.