

THIS DRAWING IS UNPUBLISHED. RELEASED FOR PUBLICATION .19
 © COPYRIGHT 19 BY AMP INCORPORATED. ALL RIGHTS RESERVED.

LOC		DIST		REVISIONS			
P	LTR	DESCRIPTION	DATE	OWN	APVD		
AD	47	A	REVISED PER EC 0430-0011-98	2-2-98	JG	SS	

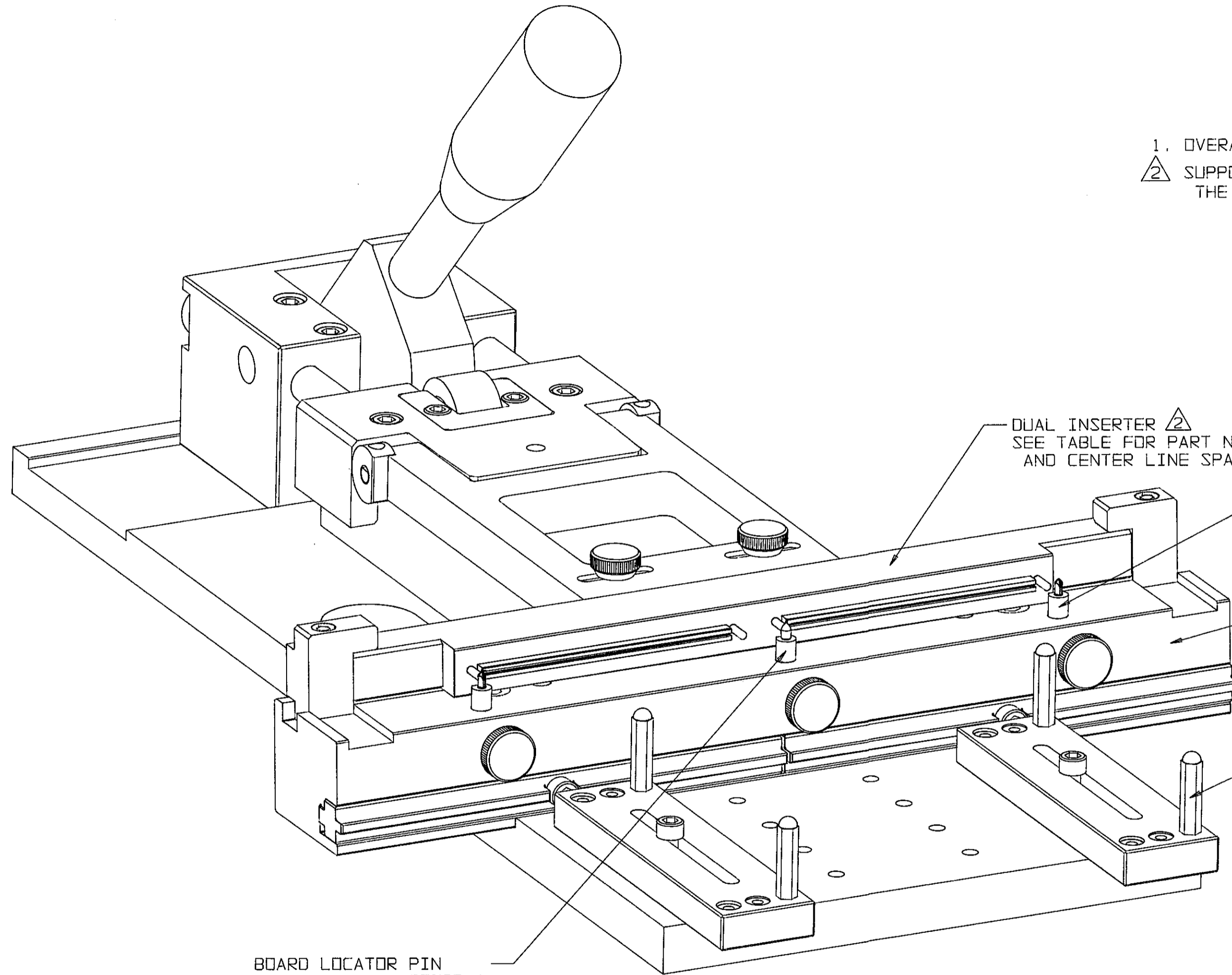

- 1. OVERALL DIMENSIONS: L - 16.1, W - 9.2, H - 8.3.
- 2. SUPPORT BLOCK SUB ASSEMBLY AND INSERTER MUST HAVE THE SAME DASH NUMBER.

DUAL INSERTER
 SEE TABLE FOR PART NUMBER
 AND CENTER LINE SPACING

BOARD LOCATOR PIN, DIAMOND HEAD
 PART NUMBER: 767526-1
 QUANTITY: 2

SUPPORT BLOCK SUB ASSEMBLY
 SEE TABLE FOR PART NUMBER

SUPPORT PILLAR
 PART NUMBER: 767522-1
 QUANTITY: 4

BOARD LOCATOR PIN
 PART NUMBER: 767523-1
 QUANTITY: 1

767594

B

767594-1
 PART
 NUMBER

767596-7	767592-7	2.706
767596-6	767592-6	2.800
767596-5	767592-5	2.750
767596-4	767592-4	2.700
767596-3	767592-3	2.650
767596-2	767592-2	2.600
767596-1	767592-1	2.550
PART NUMBER	PART NUMBER	CENTER LINE
SUPPORT BLOCK SUB-ASSY	INSERTER	

THIS DRAWING IS A CONTROLLED DOCUMENT.

OWN J. GERACE 9-19-97	AMP AMP Incorporated Harrisburg, PA 17105-3608
CHK S. STRICKLER 9-19-97	
APVD A. MONK 9-19-97	
DIMENSIONS: INCHES	TOLERANCES UNLESS OTHERWISE SPECIFIED:
0 PLC ±-	1 PLC ±-
1 PLC ±-	2 PLC ±-
2 PLC ±-	3 PLC ±-
3 PLC ±-	4 PLC ±-
4 PLC ±-	ANGLES ±-
MATERIAL	FINISH
NAME DUAL APPLICATION TOOL, RIGHT ANGLE CONNECTOR, MICTOR	SIZE A2
APPLICATION SPEC -	CAGE CODE 00779
WEIGHT -	DRAWING NO C-767594
CUSTOMER DRAWING	SCALE - SHEET 1 OF 1 REV A