

## 150mA, 75V Switching Diode

### FEATURES

- Low power loss, high efficiency
- Ideal for automated placement
- High surge current capability
- Moisture sensitivity level: level 1, per J-STD-020
- Compliance to RoHS directive 2011/65/EU and in accordance to WEEE 2002/96/EC
- Halogen-free according to IEC 61249-2-21

### APPLICATIONS

- Switching mode power supply (SMPS)
- Adapters
- Lighting application
- On-board DC/DC converter

### MECHANICAL DATA

- Case: SOD-123F
- Molding compound meets UL 94 V-0 flammability rating
- Terminal: Matte tin plated leads, solderable per J-STD-002
- Meet JESD 201 class 1A whisker test
- Polarity: Indicated by cathode band
- Weight: 8.85 ± 0.5mg

KEY PARAMETERS		
PARAMETER	VALUE	UNIT
$I_F$	150	mA
$V_{RRM}$	75	V
$I_{FSM}$	2	A
$V_F$ at $I_F=100mA$	1.00	V
$T_J$ Max.	150	°C
Package	SOD-123F	
Configuration	Single die	



ABSOLUTE MAXIMUM RATINGS ( $T_A = 25^\circ\text{C}$ unless otherwise noted)				
PARAMETER		SYMBOL	VALUE	UNIT
Marking code on the device	1N4148W		D1	
	1N4448W		D2	
	1N914BW		D3	
Power dissipation		$P_D$	400	mW
Reverse voltage		$V_R$	100	V
Repetitive peak reverse voltage		$V_{RRM}$	75	V
Forward current		$I_F$	150	mA
Repetitive peak forward current		$I_{FRM}$	300	mA
Non-repetitive peak forward surge current @ $t=1.0\mu\text{s}$		$I_{FSM}$	2	A
Junction temperature range		$T_J$	-65 to +150	°C
Storage temperature range		$T_{STG}$	-65 to +150	°C

<b>THERMAL PERFORMANCE</b>			
<b>PARAMETER</b>	<b>SYMBOL</b>	<b>TYP</b>	<b>UNIT</b>
Junction-to-ambient thermal resistance	$R_{\theta JA}$	450	$^{\circ}\text{C/W}$

<b>ELECTRICAL SPECIFICATIONS</b> ( $T_A = 25^{\circ}\text{C}$ unless otherwise noted)						
<b>PARAMETER</b>		<b>CONDITIONS</b>	<b>SYMBOL</b>	<b>MIN</b>	<b>MAX</b>	<b>UNIT</b>
Forward voltage <sup>(1)</sup>	1N4448W, 1N914BW	$I_F = 5\text{mA}, T_J = 25^{\circ}\text{C}$	$V_F$	0.62	0.72	V
	1N4148W	$I_F = 10\text{mA}, T_J = 25^{\circ}\text{C}$		-	1.00	
	1N4448W, 1N914BW	$I_F = 100\text{mA}, T_J = 25^{\circ}\text{C}$		-	1.00	
Reverse voltage	$I_R = 100\mu\text{A}, T_J = 25^{\circ}\text{C}$		$V_R$	100	-	V
	$I_R = 5\mu\text{A}, T_J = 25^{\circ}\text{C}$			75	-	
Reverse leakage current <sup>(2)</sup>	$V_R = 20\text{V}, T_J = 25^{\circ}\text{C}$		$I_R$	-	25	nA
	$V_R = 75\text{V}, T_J = 25^{\circ}\text{C}$			-	5	$\mu\text{A}$
Junction capacitance	1 MHz, $V_R = 0\text{V}$		$C_J$	-	4	pF
Reverse recovery time	$I_F = 10\text{mA}, I_R = 60\text{mA}, R_L = 100\Omega, I_{RR} = 1\text{mA}$		$t_{rr}$	-	4	ns

**Notes:**

1. Pulse test with  $PW = 0.3\text{ ms}$
2. Pulse test with  $PW = 30\text{ ms}$

<b>ORDERING INFORMATION</b>		
<b>PART NO.</b>	<b>PACKAGE</b>	<b>PACKING</b>
1N4148W RHG	SOD-123F	3K / 7" Reel
1N4148W RH	SOD-123F	3K / 7" Reel
1N4448W RHG	SOD-123F	3K / 7" Reel
1N4448W RH	SOD-123F	3K / 7" Reel
1N914BW RHG	SOD-123F	3K / 7" Reel
1N914BW RH	SOD-123F	3K / 7" Reel

**CHARACTERISTICS CURVES**

( $T_A = 25^\circ\text{C}$  unless otherwise noted)

**Fig.1 Typical Forward Characteristics**

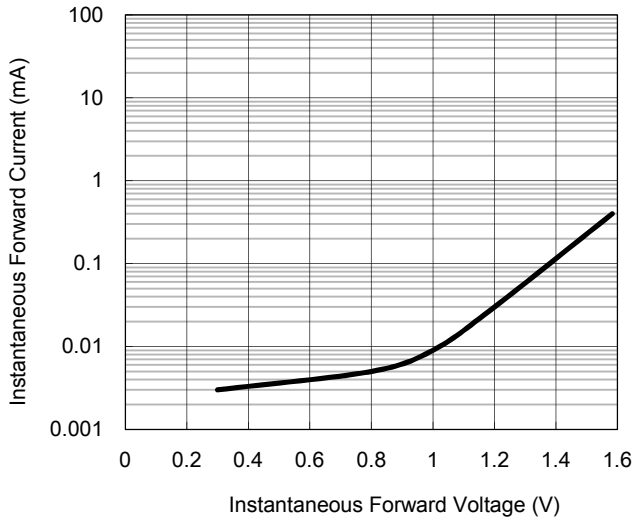

**Fig.2 Reverse Current VS. Reverse Voltage**

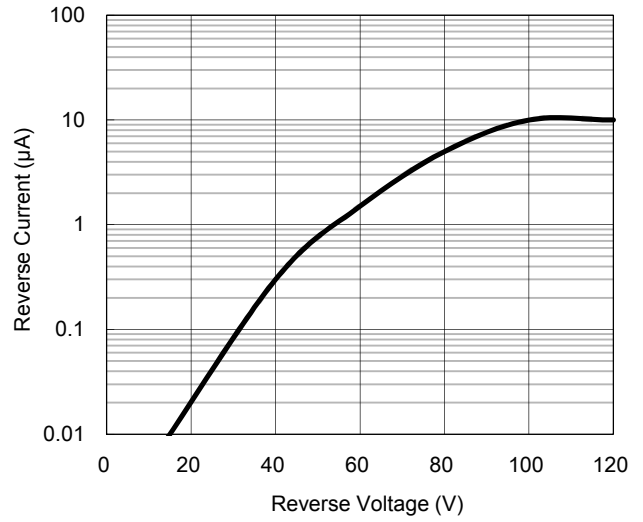

**Fig.3 Admissible Power Dissipation Curve**

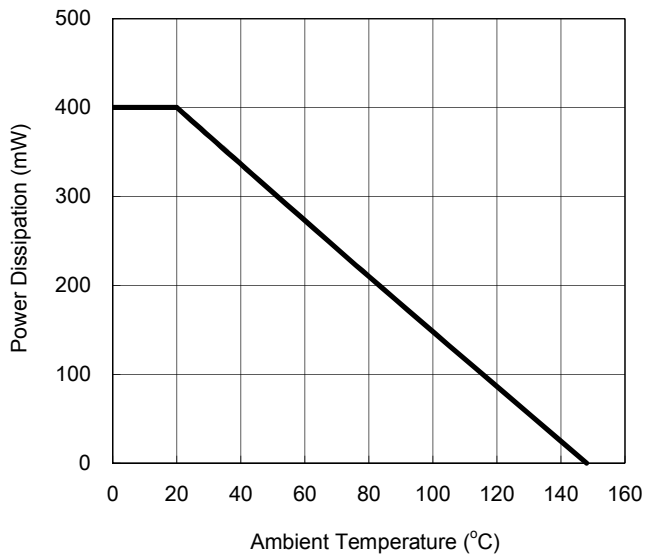

**Fig.4 Typical Junction Capacitance**

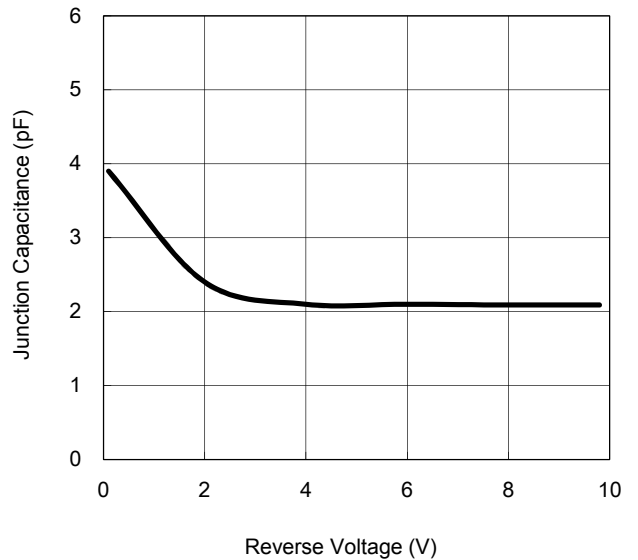

**PACKAGE OUTLINE DIMENSION**

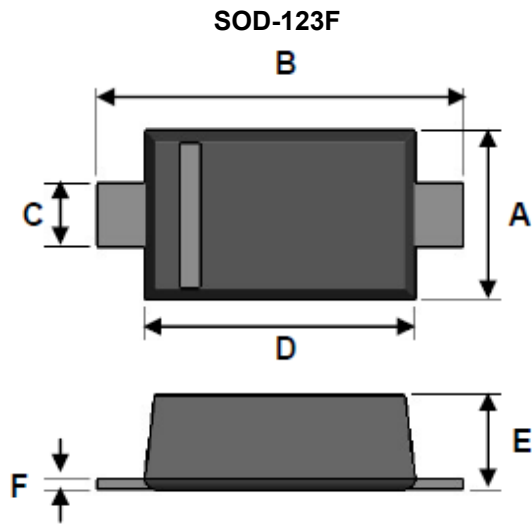

DIM.	Unit (mm)		Unit (inch)	
	Min	Max	Min	Max
A	1.50	1.70	0.059	0.067
B	3.30	3.90	0.130	0.154
C	0.50	0.70	0.020	0.028
D	2.50	2.70	0.098	0.106
E	0.80	1.15	0.031	0.045
F	0.05	0.20	0.002	0.008

**SUGGEST PAD LAYOUT**

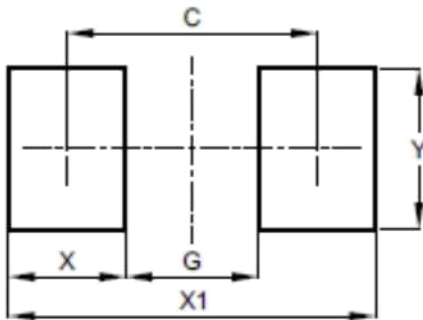

DIM.	Unit (mm)	Unit (inch)
	Typ.	Typ.
C	2.86	0.113
G	1.52	0.060
X	1.34	0.053
X1	4.20	0.165
Y	1.80	0.071



## Notice

Specifications of the products displayed herein are subject to change without notice. TSC or anyone on its behalf, assumes no responsibility or liability for any errors or inaccuracies.

Information contained herein is intended to provide a product description only. No license, express or implied, to any intellectual property rights is granted by this document. Except as provided in TSC's terms and conditions of sale for such products, TSC assumes no liability whatsoever, and disclaims any express or implied warranty, relating to sale and/or use of TSC products including liability or warranties relating to fitness for a particular purpose, merchantability, or infringement of any patent, copyright, or other intellectual property right.

The products shown herein are not designed for use in medical, life-saving, or life-sustaining applications. Customers using or selling these products for use in such applications do so at their own risk and agree to fully indemnify TSC for any damages resulting from such improper use or sale.