

**Power Crimp Head**

## **Application Tooling Specification Sheet**

**Order No. 63816-0300**

### **FEATURES**

- % Quick change power crimp head is easily installed into power crimp tool (Order No. 63816-0200) and electric crimping machine (Order No. 63816-1500)
- % Powered crimp tools help reduce fatigue and discomfort from repetitive manual crimping and allow portability
- % A precision user-friendly terminal locator wire stop holds terminals in the proper crimping position

### **SCOPE**

The 63816-0300 power crimp head was created for use with crimp dies and locator kits from Type 4C hand tool frames when used with the battery powered tool (Order No. 63816-0200) and electric crimping machine (Order No. 63816-1500).

### **INSTALLATION**

- To install the power crimp head onto the powered tool (Order No. 63816-0200), refer to the "Setup and Adjustments" section in instruction manual TM-638160200.
- To install the power crimp head onto the electric crimping machine (Order No. 63816-1500), refer to the "Mounting the Tool Head or Adapter on the Machine" section in the instruction manual TM-638161500.
- To install the crimp dies and locator kits into the power crimp head, refer to the specification sheet manual that is supplied with each kit.

**CAUTION: Never place fingers into the tooling nest.**

### **MAINTENANCE**

It is recommended that each operator of the tool be made aware of and responsible for the following maintenance steps:

1. Remove dust, moisture and other contaminants with a clean brush or a soft, lint-free cloth.
2. Do not use any abrasive materials that could damage the tool.
3. Make certain all pins, pivot points and bearing surfaces in the tool head are protected with a thin coat of high-quality machine oil. Do not oil excessively. This tool was engineered for durability, but like any fine piece of equipment, it needs cleaning and lubrication for a maximum service life of trouble-free crimping. The use of a

light oil (such as SAE 30 weight automotive oil) every 5,000 crimps or monthly will significantly enhance the tool life and ensure a stable calibration. See Figure 1 for lubrication points.

4. Store the tool in a clean and dry area when not in use.

### WARRANTY

This tool is for electrical terminal crimping purposes only. This tool is made of the best quality materials. All vital components are long life tested. All tools are warranted free of manufacturing defects for a period of 30 days. Should such a defect occur, Molex will repair or exchange the tool free of charge. This repair or exchange will not be applicable to altered, misused or damaged tools.

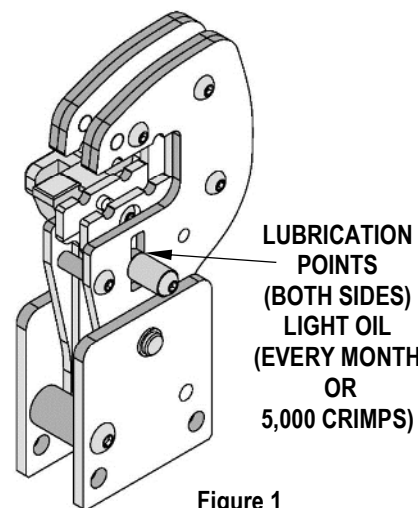

Figure 1

### PARTS LIST

Item	Order Number	Description	Quantity
1	63816-0300	Power Crimp Head	1
2	63811-4773	Universal Locator Mount	1

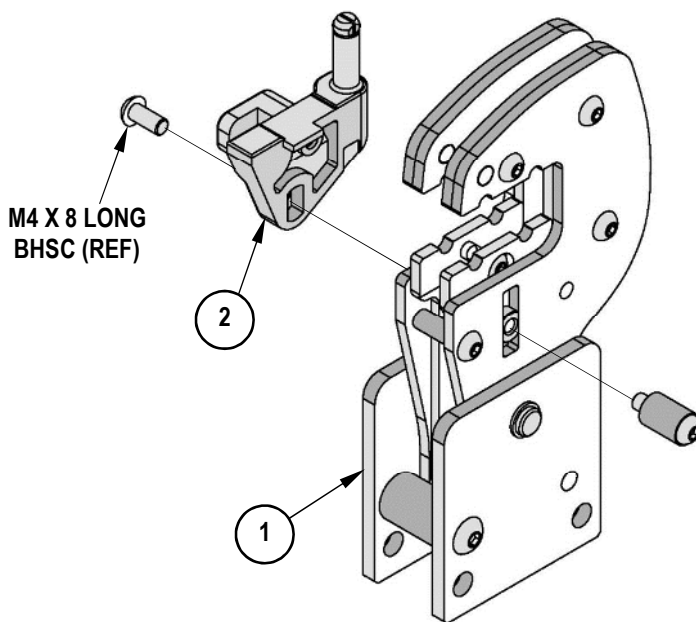

Figure 2

### Application Tooling Support

**Phone:** +1-402-458-TOOL (8665)  
**E-Mail:** applicationtooling@molex.com  
**Website:** www.molex.com/applicationtooling