

PART NUMBER	REV	FIRST USED
1385457-1	A	122500-1
1385457-2	A	565435-5
1385457-3	A	354500-1

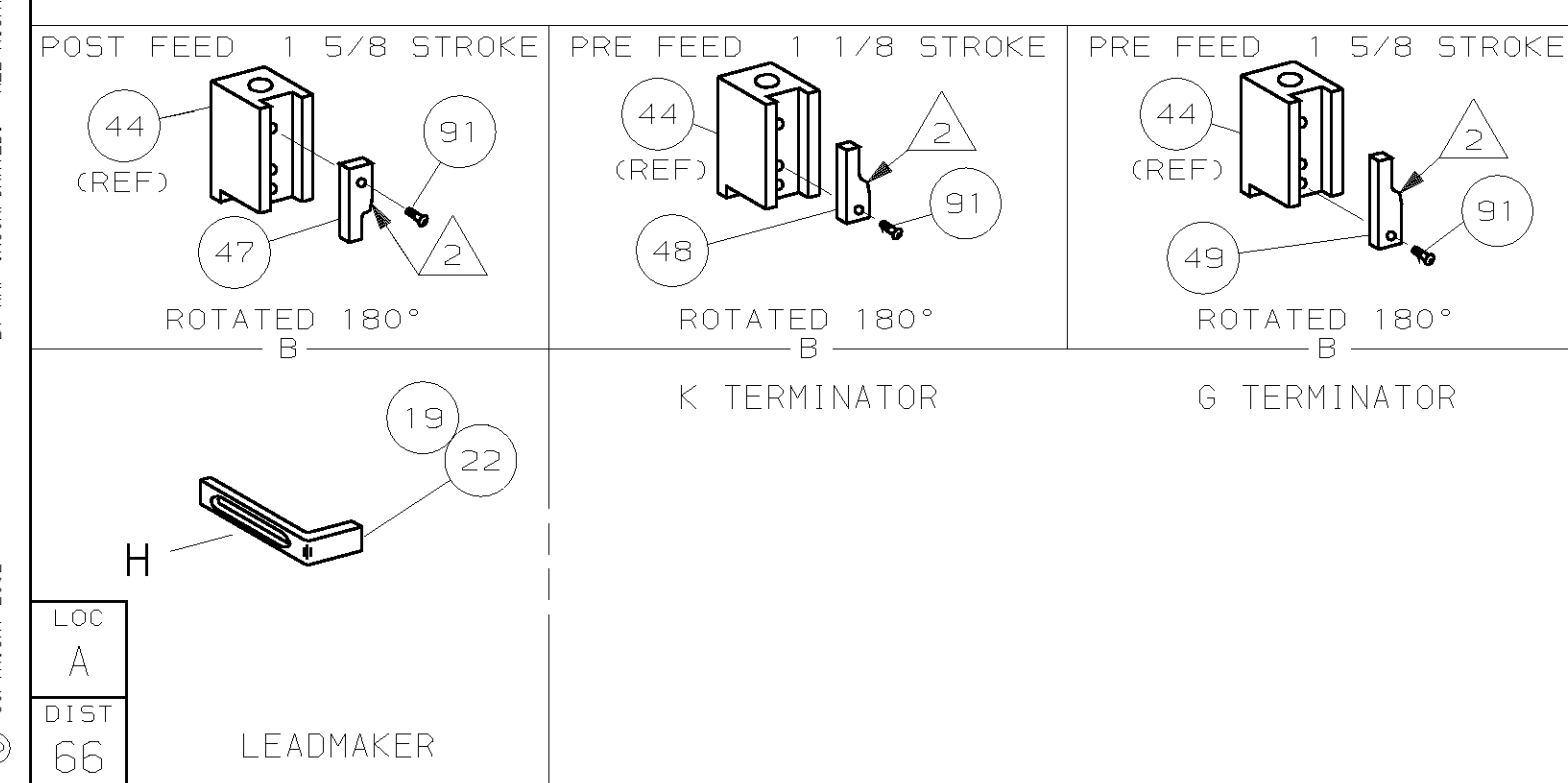
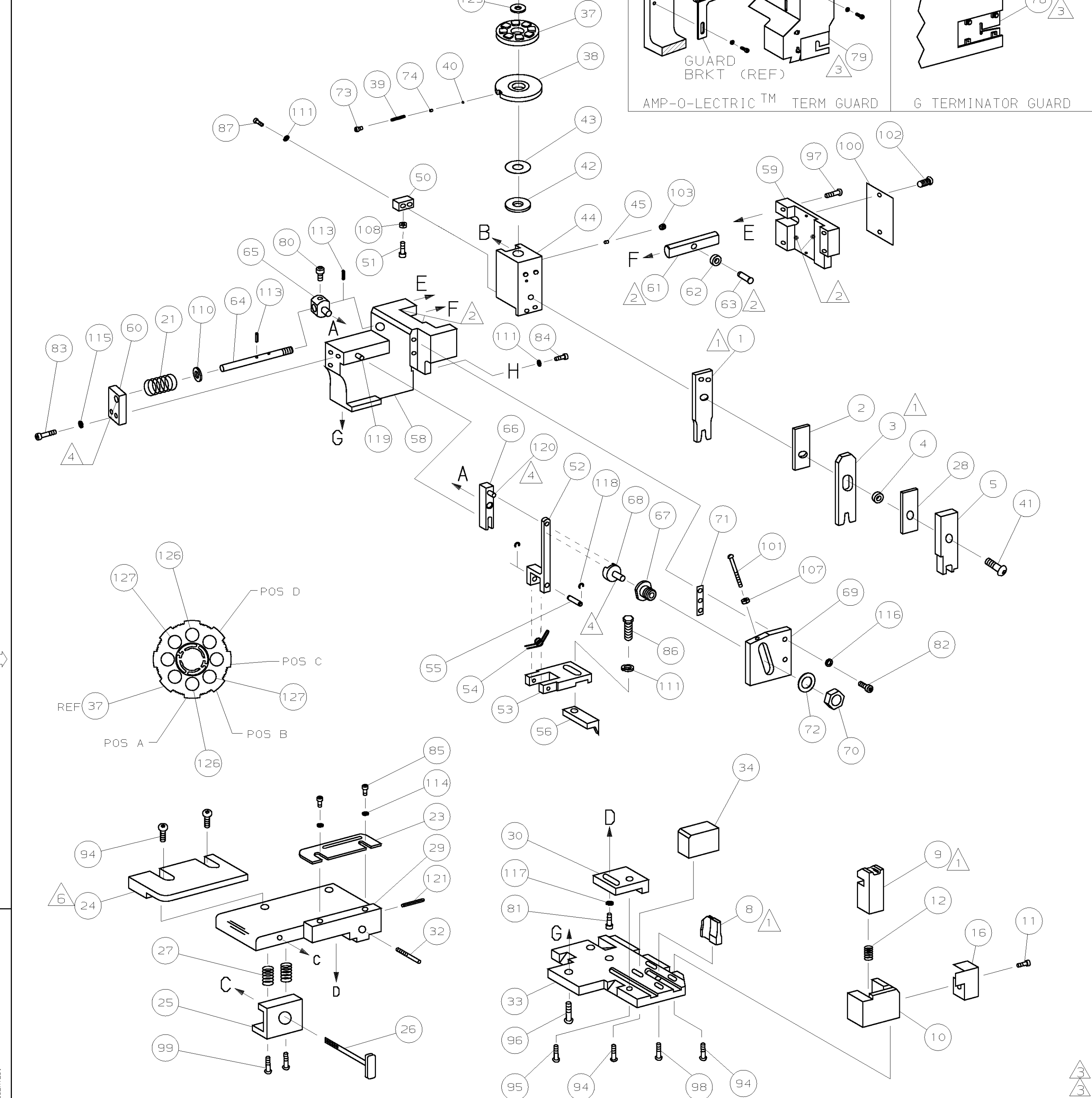

- 1 RECOMMENDED SPARE PARTS.
- 2 GREASE LIGHTLY.
- 3 GUARD MUST BE IN PLACE WHEN OPERATING APPLICATOR IN A BENCH MACHINE.
- 4 LUBRICATE DAILY USING NO. 20 MACHINE OIL.
- 5. ITEMS WITH QTY OF REF SPECIFIED (EXCEPT ITEMS 78 AND 79) ARE USED ON ITEM 46.
- 6 GUIDE OFF INSULATION LEGS

TERMINAL NAME: TERMINAL		FCI TERMINAL		AMP CRIMP SPECS	
AMP TERM	PN/MFR	TERM PN	CRIMP HEIGHT	WIRE SIZE	
1572125	JPT-1811-29		A .056 ±.002 [1.42 ±0.05mm]	18	
			B .051 ±.002 [1.30 ±0.05mm]	20	
			C NOT	USED	
			D NOT	USED	
CRIMP		SIZE	TYPE	RANGE	
WIRE	.080	[2.03mm]	F	20-18	
INSUL	.100	[2.54mm]	F	-	

QTY	REF	REF	REF	U/M	DWG SIZE	PART NO	DESCRIPTION	ITEM NO
1	1	1	1	-	A	21009-2	SCR, 5KT 5ET (1/4-20x.25 LW) RAM	103
2	2	2	2	-	A	21017-2	SCR, DRIVE (#2x.19) ID PLATE	102
REF	REF	REF	REF	-	A	6-23715-5	SCR, PAN HD (6-32x1.50) FEED ADJ	101
1	1	1	1	-	B	461264-1	PLATE, IDENTIFICATION	100
2	2	2	2	-	A	3-21002-0	SCR, BHC (10-32x.88) DRAG	99
1	1	1	1	-	A	22733-8	SCR, BHC (8-32x.38 LW) ANVIL	98
REF	REF	REF	REF	-	A	2-21002-9	SCR, BHC (10-32x.75) CAP	97
REF	REF	REF	REF	-	A	2-22733-8	SCR, BHC (1/4-20x.62) HOUSING	96
REF	REF	REF	REF	-	A	2-21002-7	SCR, BHC (10-32x.50) 56 ADJ BLOCK	95
6	6	6	6	-	A	2-21002-2	SCR, BHC (8-32x.50) TERM H DWN	94
1	1	1	1	-	A	1-21002-7	SCR, BHC (6-32x.38) CAM	91
2	2	2	2	-	A	2-21000-7	SCR, SHC (8-32x.44) DEP-HOLD	87
1	1	1	1	-	A	2-22603-0	SCR, HEX HD (8-32x.31) FEED FINGER	86
2	2	2	2	-	A	1-21000-3	SCR, SHC (4-40x.25) FR ST GUIDE	85
1	1	1	1	-	A	2-21000-7	SCR, SHC (8-32x.50) STRIPPER	84
REF	REF	REF	REF	-	A	3-21000-7	SCR, SHC (10-32x.75) FEED ROD GD	83
REF	REF	REF	REF	-	A	3-21000-6	SCR, SHC (10-32x.62) FD ADJ BLK	82
1	1	1	1	-	A	3-21000-4	SCR, SHC (10-32x.38) 56 ADJ BL	81
REF	REF	REF	REF	-	A	3-21000-4	SCR, SHC (10-32x.38) PIVOT BLK	80
-	REF	-	-	-	B	455749-1	GUARD, WINDOW	79
REF	-	-	-	-	B	679532-1	INSERT, GUARD	78
1	1	1	1	-	A	690603-1	SPRING, ASSIST	74
1	1	1	1	-	A	23030-1	SCR, SHC (6-32x.25 SL) INS DISC	73
REF	REF	REF	REF	-	A	458109-1	WASHER, SPECIAL	72
REF	REF	REF	REF	-	A	690517-1	SPACER	71

QTY	REF	REF	REF	U/M	DWG SIZE	PART NO	DESCRIPTION	ITEM NO
-1							LEADMAKER	
-2							BENCH MODEL K	
-3							BENCH MODEL G	
REF	REF	REF	REF	-	B	22594-8	NUT, HEX (1/2-20)	70
REF	REF	REF	REF	-	B	240628-1	PLATE, ADJUSTMENT	69
REF	REF	REF	REF	-	B	240626-1	SHAFT, PIVOT	68
REF	REF	REF	REF	-	B	240633-1	BUSHING	67
REF	REF	REF	REF	-	A	455680-1	LEVER, INTERMEDIATE	66
REF	REF	REF	REF	-	B	240629-1	BLOCK, PIVOT	65
REF	REF	REF	REF	-	A	240632-2	SCREW, ADJ FEED ROD	64
REF	REF	REF	REF	-	B	240659-3	PIN, CAM ROLLER	63
REF	REF	REF	REF	-	B	240658-1	ROLLER, CAM	62
REF	REF	REF	REF	-	B	454398-2	ROD, FEED	61
REF	REF	REF	REF	-	A	454178-1	GUIDE, FEED ROD	60
REF	REF	REF	REF	-	C	454220-1	CAP, RAM	59
REF	REF	REF	REF	-	D	454485-1	HOUSING	58
1	1	1	1	-	B	458537-2	PAWL, FEED	56
REF	REF	REF	REF	-	B	240624-1	PIN, FEED FINGER	55
REF	REF	REF	REF	-	B	691499-1	SPRING, FEED FINGER	54
REF	REF	REF	REF	-	B	690541-1	HOLDER, FEED FINGER	53
REF	REF	REF	REF	-	A	455679-2	LEVER, TERMINAL FEED ARM	52
1	1	1	1	-	A	811242-2	BUMPER, HOLDDOWN	51
1	1	1	1	-	A	690753-1	SPACER, TONKER	50
1	-	-	-	-	B	690602-6	CAM, PRE-FEED 1 5/8 ST	49
-	1	-	-	-	B	690602-5	CAM, PRE-FEED 1 1/8 ST	48
-	-	-	-	-	B	690501-4	CAM, POST-FEED 1 5/8 ST	47
1	1	1	1	-	B	459456-2	APPLICATOR, BASIC (SUBASSY)	46
1	1	1	1	-	A	690191-1	PLUG, NYLON	45
1	1	1	1	-	C	455673-1	RAM	44
1	1	1	1	-	A	690125-1	WASHER, LAMINATED	43
1	1	1	1	-	A	690124-1	WASHER, RAM	42
1	1	1	1	-	A	7-21002-9	BOLT, CRIMPER (5/16x1.00)	41
1	1	1	1	-	A	23241-6	BALL, STEEL	40
1	1	1	1	-	A	690170-1	SPRING, COMPRESSION	39
1	1	1	1	-	C	690142-1	DISC, INSULATION	38
1	1	1	1	-	D	354777-1	WIRE DISC, PLASTIC	37
1	1	1	1	-	A	22480-5	WASHER, SPRING	36
1	1	1	1	-	B	690212-1	POST, RAM	35
1	1	1	1	-	B	690786-3	SUPPORT, TERMINAL	34
REF	REF	REF	REF	-	D	455675-1	PLATE, BASE	33
1	1	1	1	-	A	690432-3	SCREW, ADJUSTMENT	32
REF	REF	REF	REF	-	B	455689-1	BLOCK, STRIP GUIDE ADJ	30
1	1	1	1	-	C	455671-1	PLATE, STRIP GUIDE	29
1	1	1	1	-	C	1-455888-0	SPACER, FRONT SHEAR DEP	28
2	2	2	2	-	A	1-22284-0	SPRING, DRAG	27
1	1	1	1	-	B	690546-1	LEVER, DRAG RELEASE	26
1	1	1	1	-	B	240792-1	DRAG, TERMINAL	25
1	1	1	1	-	D	6-690504-8	GUIDE, STRIP (REAR)	24
1	1	1	1	-	A	690438-1	GUIDE, STRIP (FRONT)	23
-	-	-	-	-	B	690472-2	STRIPPER	22
REF	REF	REF	REF	-	A	4-22284-9	SPRING, FEED RETURN	21
1	1	1	1	-	B	690472-1	STRIPPER	20
1	1	1	1	-	B	318563-1	GUARD, CHIP, FRONT	16
1	1	1	1	-	A	5-22280-0	SPRING, SHEAR	12
1	1	1	1	-	B	690461-1	STOP, SHEAR	11
1	1	1	1	-	C	690459-1	HOLDER, SHEAR (FRONT)	10
1	1	1	1	-	C	1-454276-9	SHEAR, FLOAT (FRONT)	9
1	1	1	1	-	C	6-805887-8	ANVIL	8
1	1	1	1	-	C	1-455889-4	DEPRESSOR, SHEAR (FRONT)	5
1	1	1	1	-	B	238011-2	SPACER, BLOCK CRIMPER	4
1	1	1	1	-	C	4-456134-0	CRIMPER, INSULATION	3
1	1	1	1	-	C	455888-4	SPACER, CRIMPER	2
1	1	1	1	-	C	1-456405-3	CRIMPER, WIRE	1

THIS DRAWING IS A CONTROLLED DOCUMENT.

THIS DRAWING IS UNRELEASED. RELEASE FOR PUBLICATION BY AMP INCORPORATED. ALL RIGHTS RESERVED. 2002

1385457

REVISION OF EACH ASSY NO (WHEN BLANK, USE DWG REVISION)

QTY	REF	REF	REF	U/M	DWG SIZE	PART NO	DESCRIPTION	ITEM NO
-3	-2	-1						

DIMENSIONS IN INCHES. DO NOT SCALE PRINT. TOLERANCES UNLESS OTHERWISE SPECIFIED:  
 2 PLC DEC ±  
 3 PLC DEC ±  
 4 PLC DEC ±  
 ANGLES ±  
 SURF TEXTURE: ✓  
 REMOVE BURRS, BREAK SHARP EDGES R.015 MAX

MATL: - HT TR: - FIN: -

DR: B.HIGMAN 30JUL02 APP: T.ELBIN 30JUL02  
 CHK: - REL: -

AMP Incorporated Harrisburg, PA 17105-3608

NAME: SIDE FEED HDM APPLICATOR MACHINE REF: MINI APPL  
 SCALE: - DWG NO: 1385457 SHEET: 1 OF 1 REV: A

CASE CODE: 00779 CUSTOMER AND ASSEMBLY DRAWING