

REVISIONS					
P	LTR	DESCRIPTION	DATE	DWN	APVD
G1		REVISED PER ECN-23-199892	01MAR2023	RK	MZ

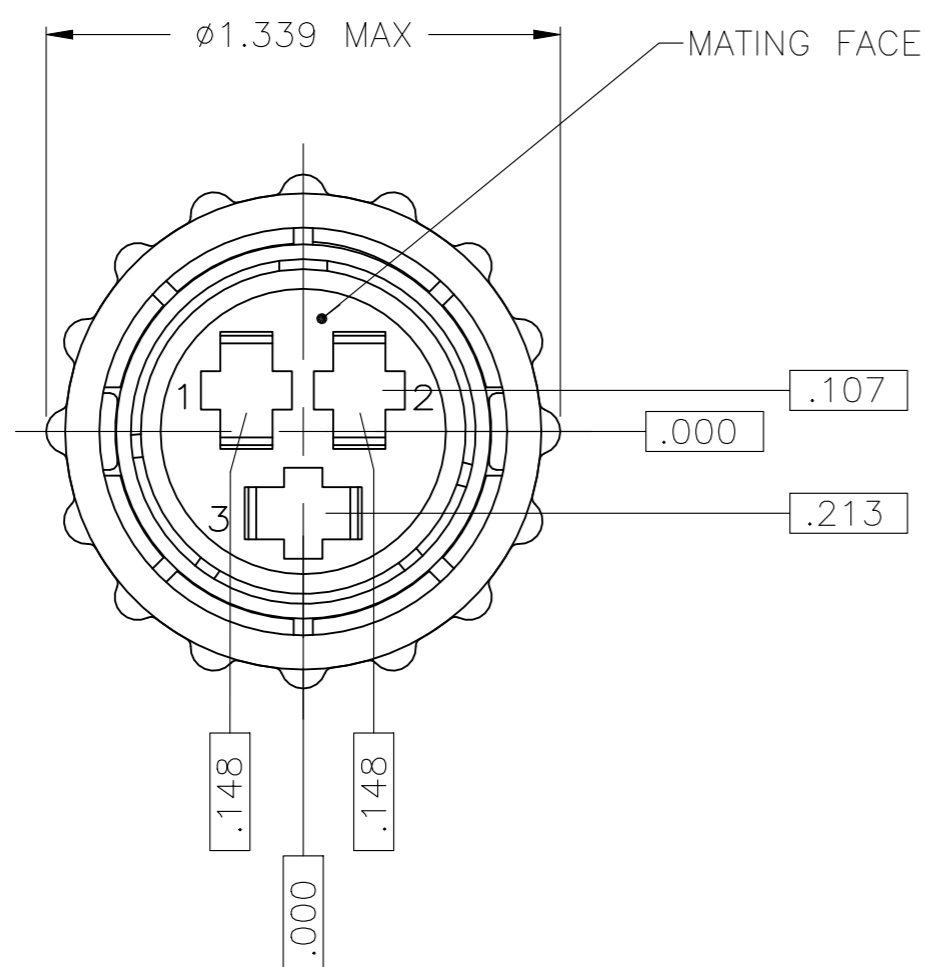

206426-1 & -2

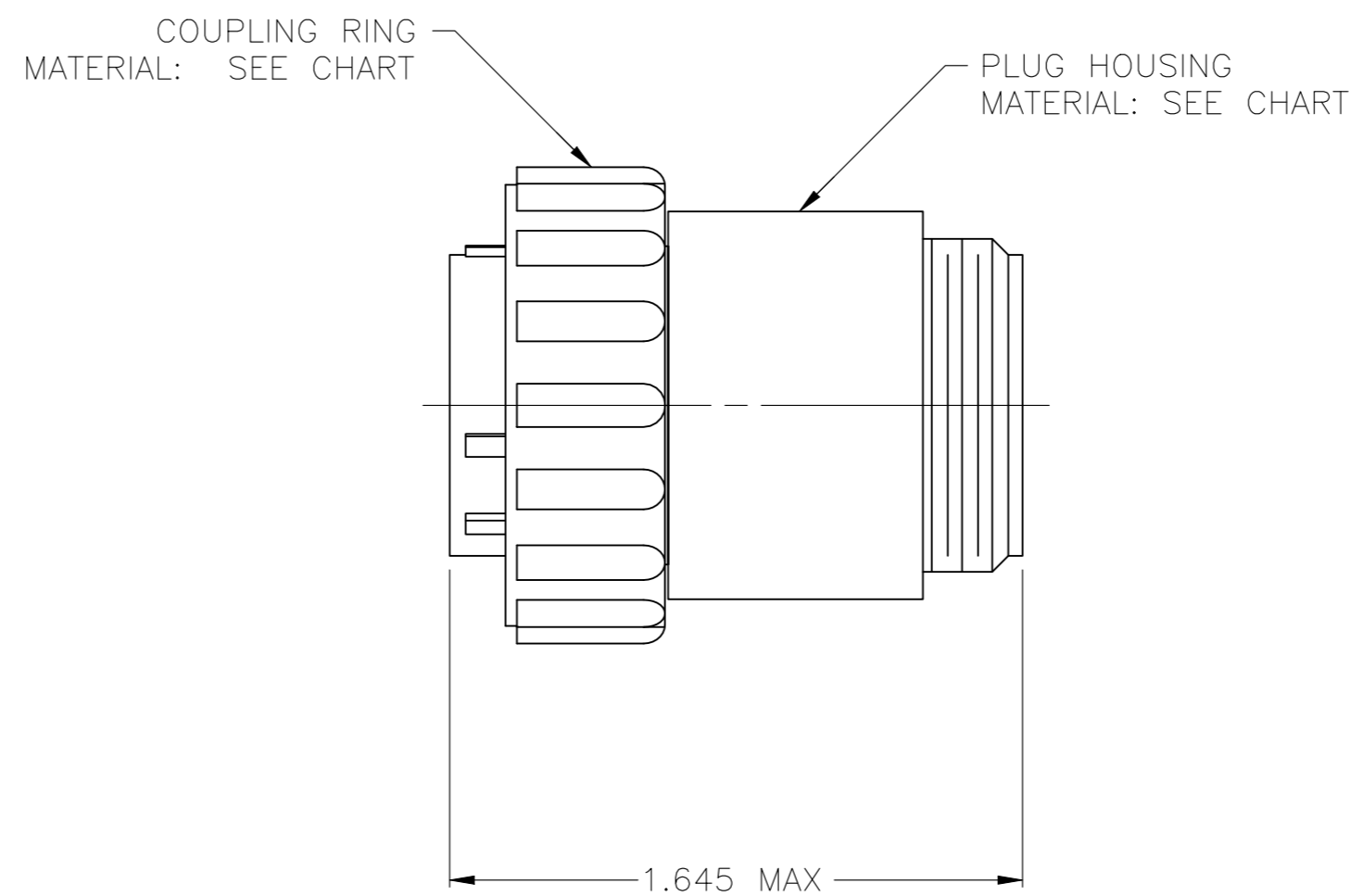

- 1 CONTACT CAVITIES IDENTIFIED BY CHARACTERS ON FRONT AND REAR FACES OF CONNECTOR.
- 2 WILL ACCEPT (3) TYPE XII PIN CONTACTS.

	A	POLYESTER, BLACK	POLYESTER, BLACK	206426-5
OBSOLETE	B	POLYESTER, BLACK	PA66, BLACK	206426-4
OBSOLETE	A	POLYESTER, GRAY	PA66, BLACK	206426-2
	A	POLYESTER, BLACK	PA66, BLACK	206426-1
	KEYING STYLE	COUPLING RING MATERIAL	PLUG HOUSING MATERIAL	PART NUMBER

THIS DRAWING IS A CONTROLLED DOCUMENT.		DWN S.RIDGLEY BG 8/2/90	TE TE Connectivity	
DIMENSIONS: INCHES		CHK R.STONE 04/26/91		
TOLERANCES UNLESS OTHERWISE SPECIFIED:		APVD -	NAME PLUG ASSEMBLY, SHELL SIZE 17, REVERSE SEX, SERIES 3, CPC	
0 PLC ± -		PRODUCT SPEC -	SIZE A2	
1 PLC ± -		APPLICATION SPEC -	CAGE CODE 00779	DRAWING NO C=206426
2 PLC ± -		WEIGHT -	RESTRICTED TO -	
3 PLC ± -		FINISH -	SCALE 2:1	SHEET 1 OF 1
4 PLC ± -		MATERIAL SEE	REV G1	
ANGLES ± -		CUSTOMER DRAWING		