

REVISIONS				
P	LTN	DESCRIPTION	DATE	APP'D
C		REVISED PER ECO-17-012537	25AUG2017	TX SH
D		REVISED PER ECO-18-014172	06SEP2018	TX SH
E		REVISED PER ECO-18-018343	22NOV2018	TX SH

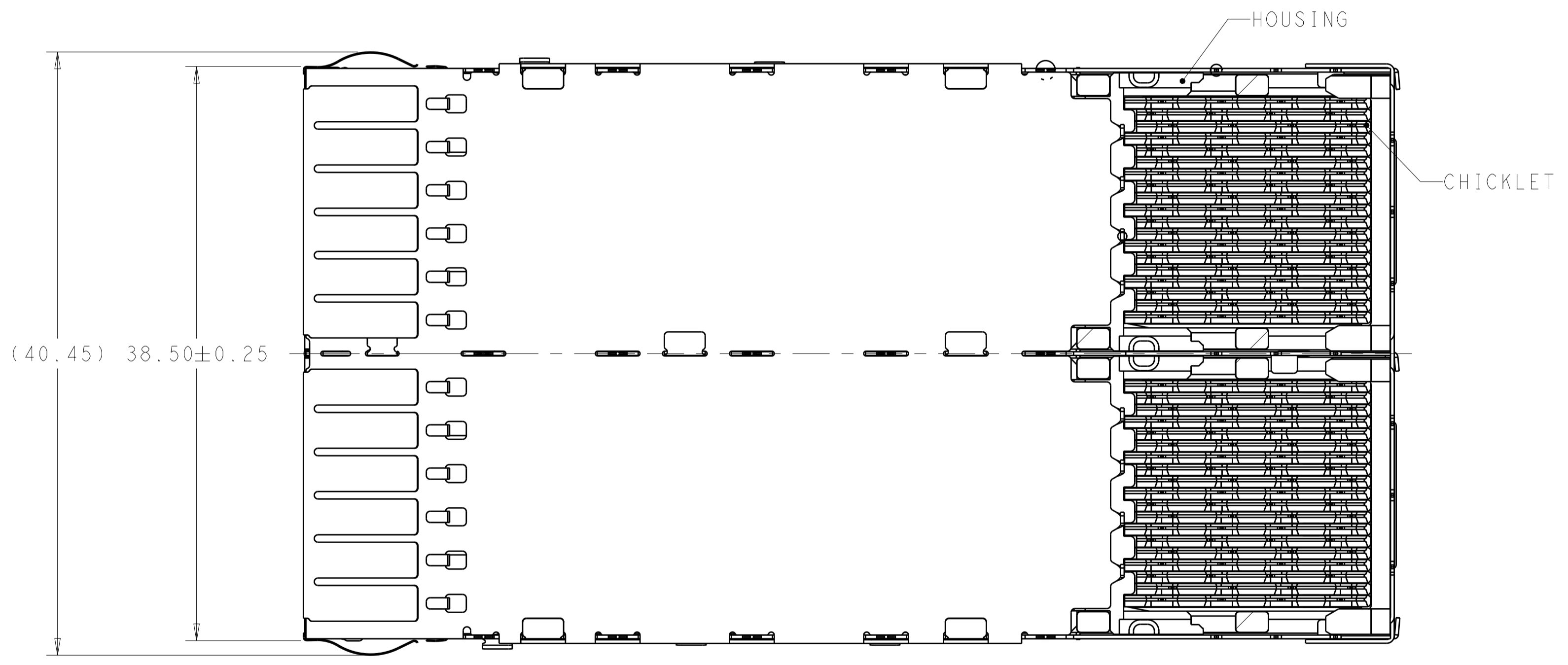
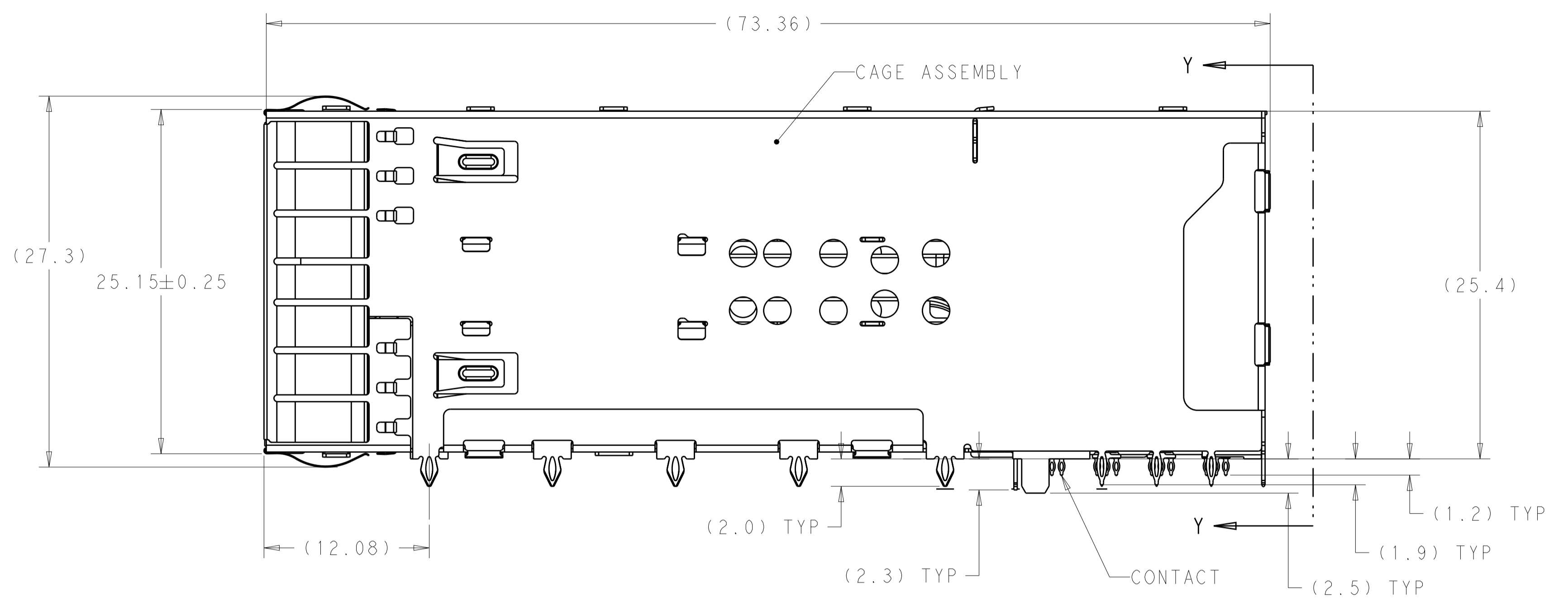
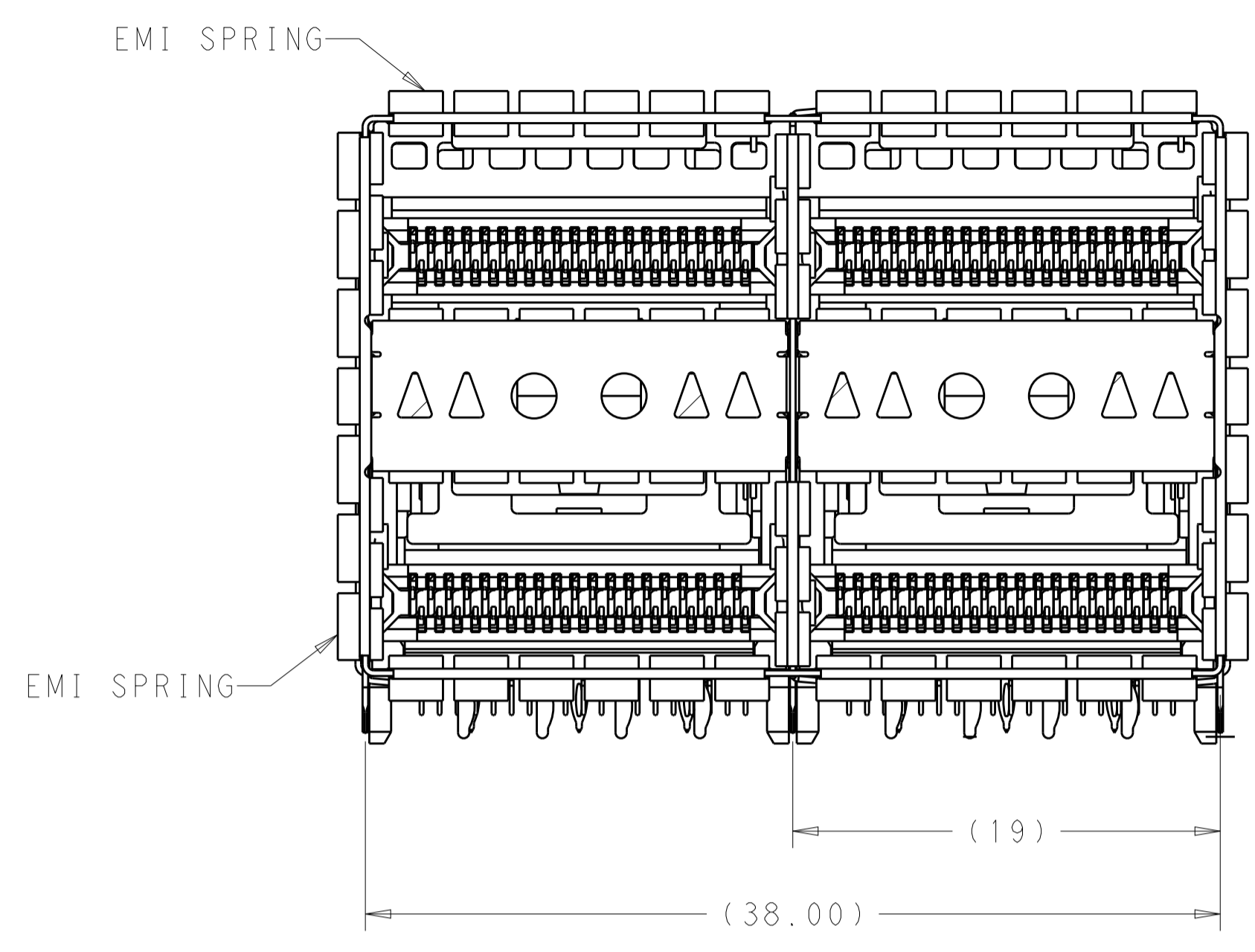

- MATERIALS:  
 CAGE ASSEMBLY- NICKEL SILVER ALLOY PER ASTM B 122.  
 EMI SPRING- COPPER ALLOY, NICKEL PLATED.  
 HOUSING- POLYESTER LCP WITH 94V-0.  
 CHICKLET- POLYESTER LCP WITH 94V-0.  
 CONTACT- COPPER ALLOY.  
 LIGHTPIPE- POLYCARBONATE WITH 94V-0.
- CONTACT FINISH: 0.76µm GOLD ON MATING AREA, 0.7-1.5µm MATT TIN ON COMPLIANT AREA, ALL OVER 1.27µm NICKEL.
- DATUM AND BASIC DIMENSION ESTABLISHED BY CUSTOMER.
- MINIMUM PCB THICKNESS OF 1.57.
- THE ENTIRE AREA OF THE CONNECTOR FOOTPRINT, INDICATED BY THE DASHED LINE, TO BE CONSIDERED THE KEEPOUT AREA FOR COMPONENTS AND TRACES.
- CROSS-HATCHED AREAS REPRESENT ZONES ON THE PCB THAT COME IN CONTACT WITH OR BE IN CLOSE PROXIMITY TO THE PLASTIC HOUSING OR THE CONNECTOR CAGE. INDICATED AREAS TO BE CONSIDERED TRACE FREE.
- PART NUMBER AND DATE CODE MADE IN APPROXIMATE AREA SHOWN.
- HATCHED AREA IS PLACEMENT ZONE FOR LED. LED SHOULD BE CENTERED WITHIN ZONE. RECOMMEND 0805 PACKAGE.
- CONTACT FINISH: 0.08µm MINIMUM GOLD OVER 0.68µm PALLADIUM-NICKEL ON MATING AREA, 0.7-1.5µm MATT TIN ON COMPLIANT AREA, ALL OVER 1.27µm NICKEL.
- REMOVE THE PCB HOLES FOR 2289129-5, 2289129-8 FOR BELLY TO BELLY APPLICATION.

CONTACT FINISH	DESCRIPTION	PART NUMBER
2	LEFT INDICATOR DOWN, 4LP	1-2289129-3
2	ALL INDICATOR UP, 4LP	1-2289129-1
2	ALL ROUND INDICATOR, 4LP	2289129-9
2	ALL ROUND INDICATOR, 4LP	2289129-8
2	LEFT INDICATOR UP, 2LP	2289129-7
2	ALL INDICATOR DOWN, 4LP	2289129-6
2	LEFT INDICATOR UP, 2LP	2289129-5
2	LEFT INDICATOR UP, 4LP	2289129-4
2	LEFT INDICATOR DOWN, 4LP	2289129-3
2	LEFT INDICATOR UP, 4LP	2289129-2
2	ALL INDICATOR UP, 4LP	2289129-1

THIS DRAWING IS A CONTROLLED DOCUMENT. DIMENSIONS: mm. TOLERANCES UNLESS OTHERWISE SPECIFIED: 0 PLC ±0.25, 1 PLC ±0.15, 2 PLC ±0.15, 3 PLC ±0.15, 4 PLC ±0.15, ANGLES ±0.15. MATERIAL: SEE NOTE 1. FINISH: SEE NOTE 2. CUSTOMER DRAWING. SCALE: 4:1. SHEET 1 OF 6. REV E.

OWN: TIM XUE 30NOV2014  
 CH: JASON YANG 30NOV2014  
 APVD: JASON YANG 30NOV2014  
 NAME: ZOSFP+ 2X2 WITH EMI SPRING FINGERS 4 INTERNAL LIGHT PIPES  
 PRODUCT SPEC: 108-60102  
 APPLICATION SPEC: 114-60015  
 SIZE: CAGE CODE DRAWING NO: A100779  
 WEIGHT: 2289129  
 RESTRICTED TO: CUSTOMER DRAWING

**STE** TE Connectivity

REVISIONS				
P.	LTN.	DESCRIPTION	DATE	APP'D.
-	-	SEE SHEET 1	-	-

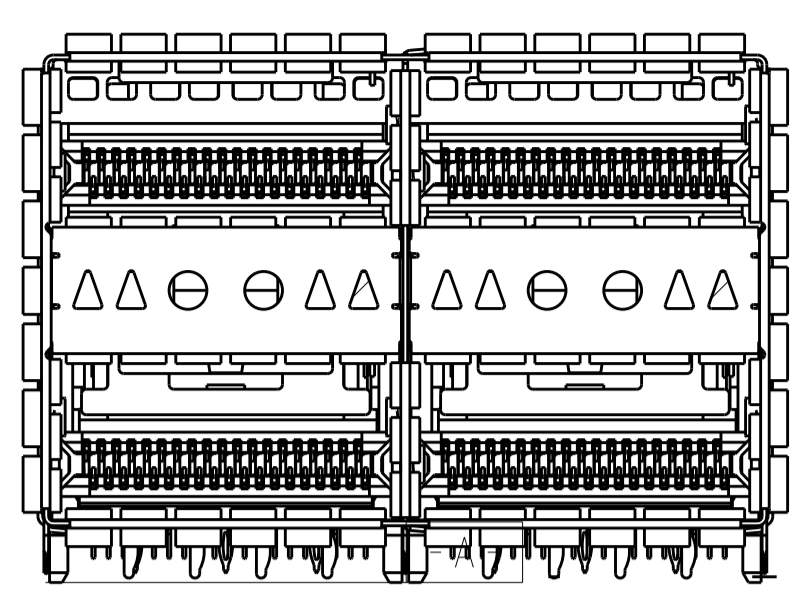

2289129-1  
ALL INDICATORS UP  
SCALE 5:2

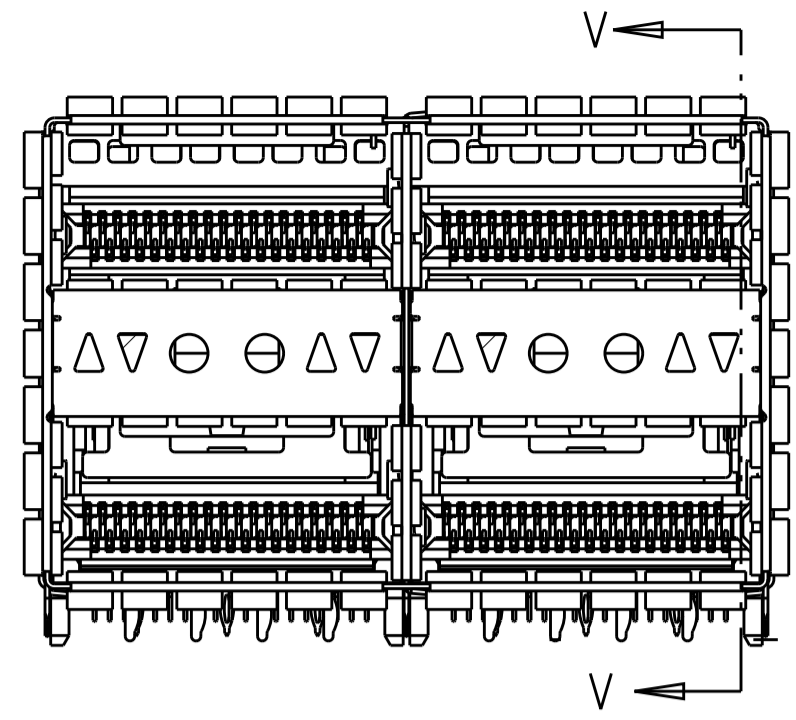

2289129-2  
LEFT INDICATOR UP  
SCALE 5:2

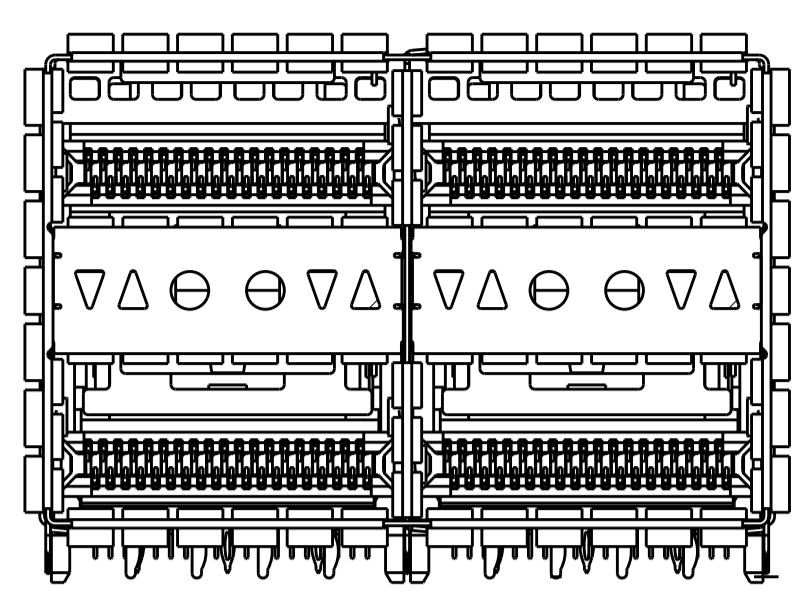

2289129-3  
LEFT INDICATOR DOWN  
SCALE 5:2

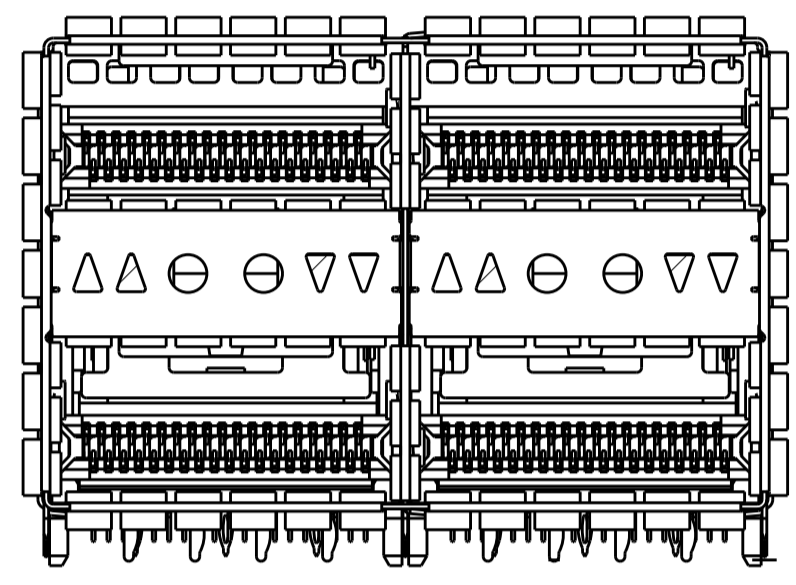

2289129-4  
LEFT INDICATOR UP  
SCALE 5:2

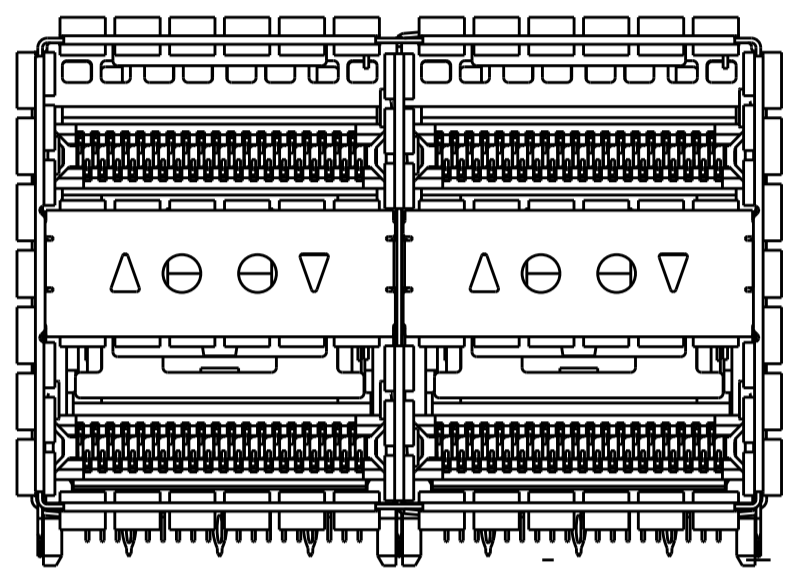

2289129-5  
2289129-7  
LEFT INDICATORS UP(2 LIGHT PIPES)  
SCALE 5:2

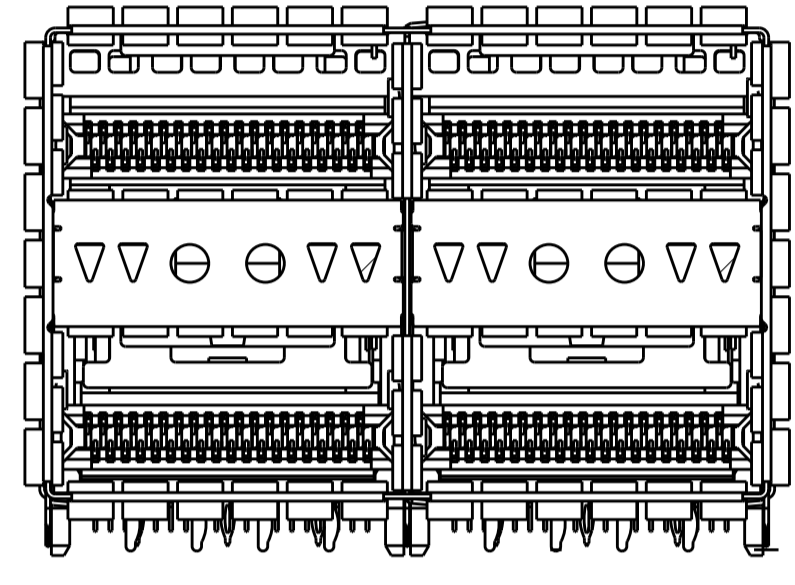

2289129-6  
ALL INDICATORS DOWN  
SCALE 5:2

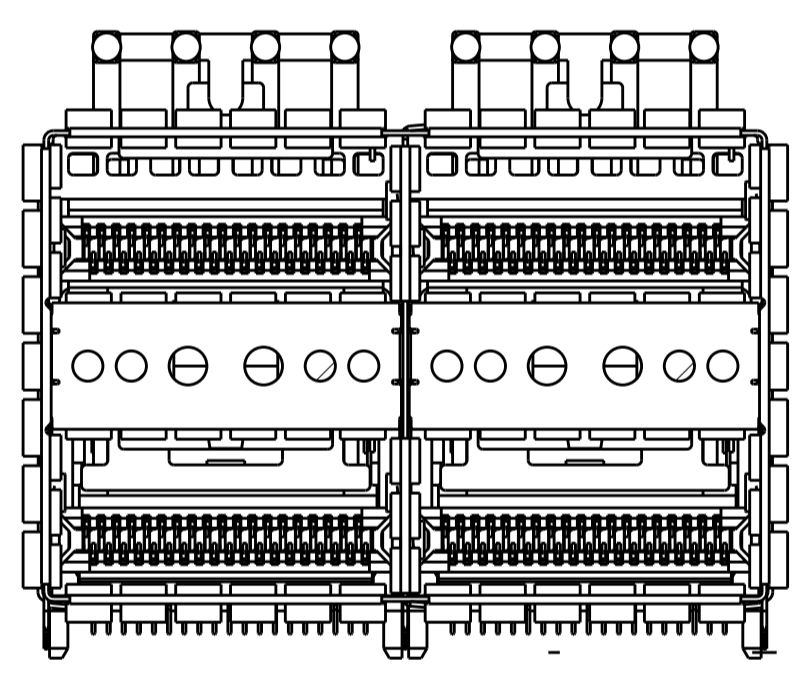

2289129-8  
SCALE 5:2

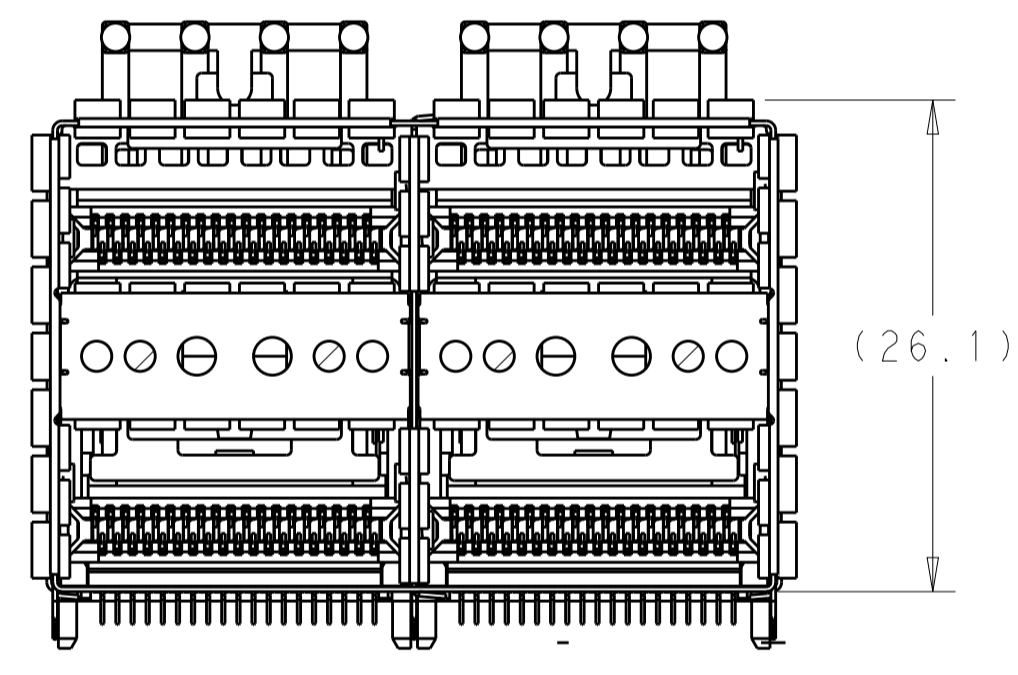

2289129-9 SAME TO 2289129-8  
EXCEPT REMOVE THE BOTTOM SPRINGS  
SCALE 5:2

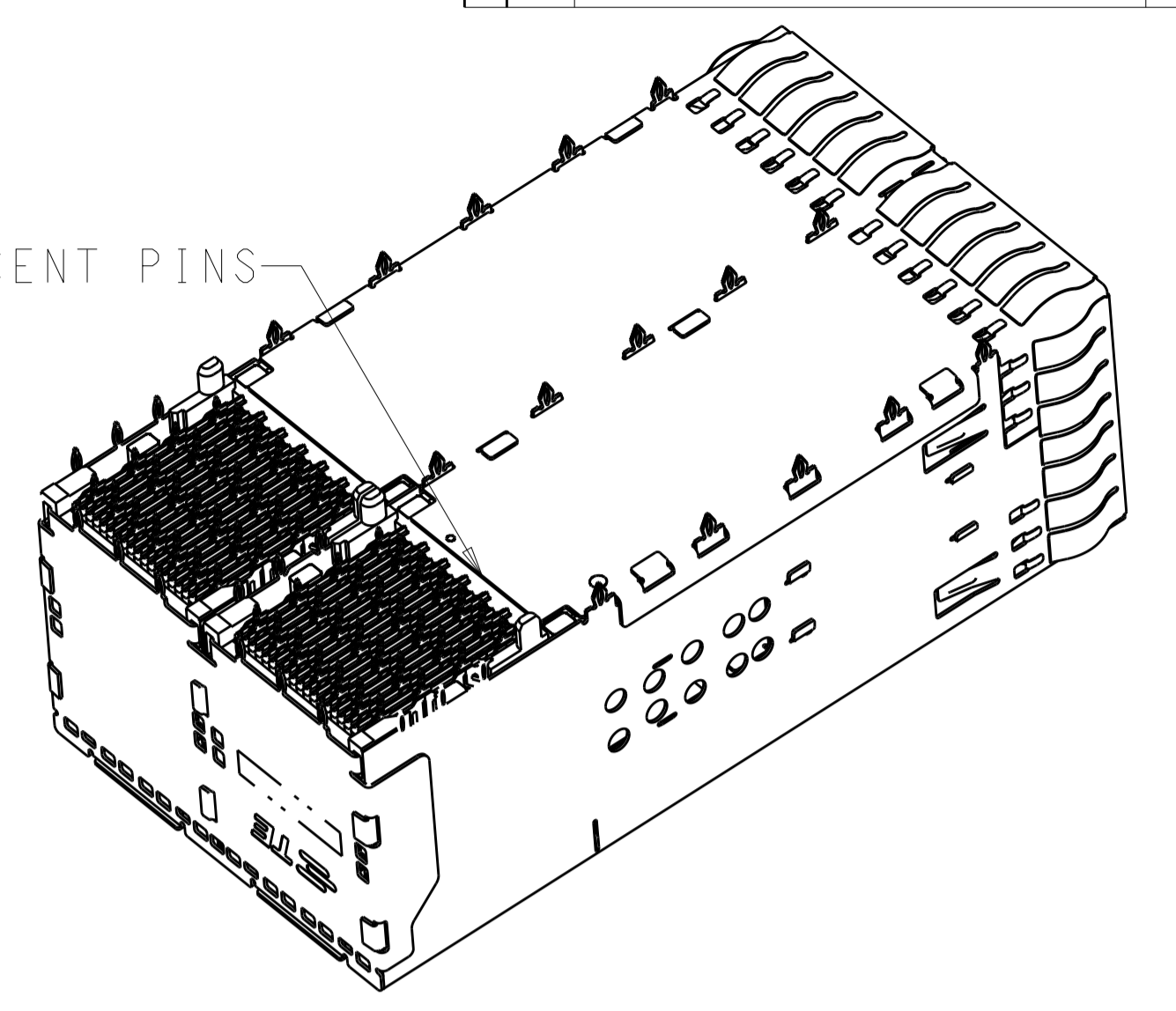

2289129-5, 2289129-7  
WITHOUT CRESCENT PINS AS SHOWN  
SCALE 2:1

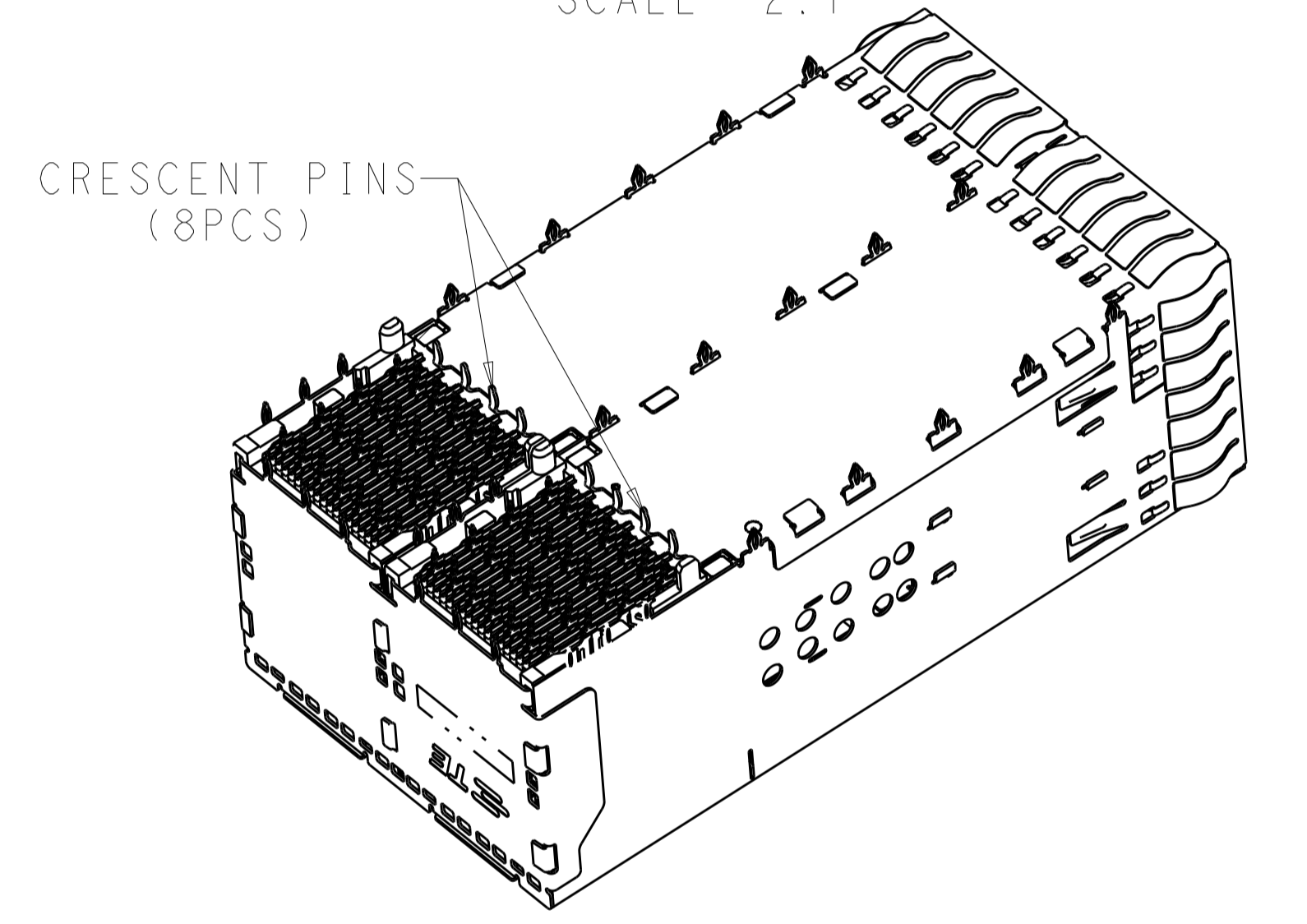

2289129-1 TO 2289129-4 & 2289129-6  
WITH CRESCENT PINS AS SHOWN  
SCALE 2:1

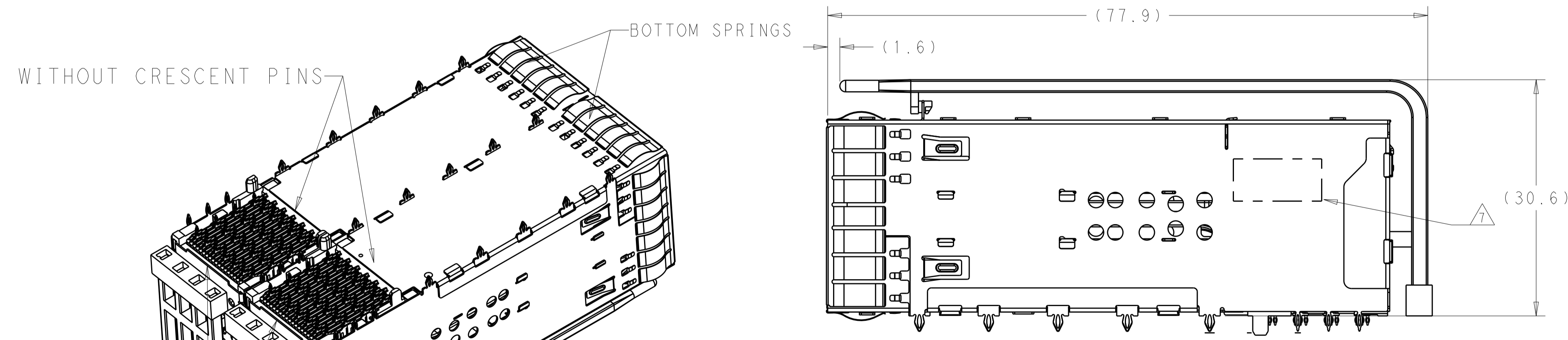

2289129-8  
2289129-9 WITHOUT BOTTOM SPRINGS  
SCALE 5:2

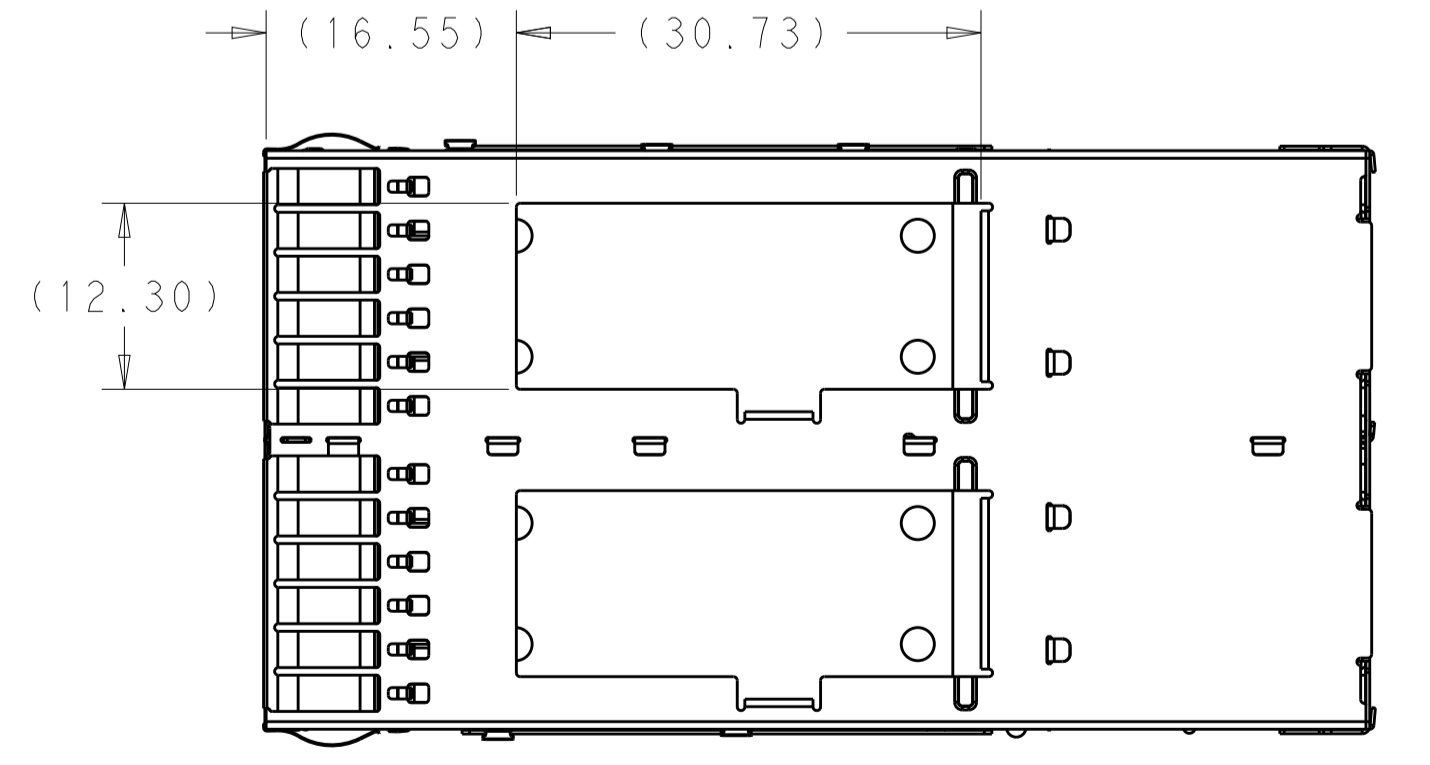

2289129-7 AS SHOWN WITH TOP SLOTS  
SCALE 2:1

WITHOUT 3 EONS PER PORT

2289129-8  
SCALE 2:1

THIS DRAWING IS A CONTROLLED DOCUMENT.		OWN: TIM XUE 30NOV2014	TE Connectivity
DIMENSIONS: mm		CHK: JASON YANG 30NOV2014	
TOLERANCES UNLESS OTHERWISE SPECIFIED:		APP'D: JASON YANG 30NOV2014	NAME: ZOSFP+ 2X2 WITH EMI SPRING FINGERS 4 INTERNAL LIGHT PIPES
0 PLC ±		PRODUCT SPEC: 108-60102	SIZE: CAGE CODE DRAWING NO: 114-60015
1 PLC ±0.25		APPLICATION SPEC: 114-60015	RESTRICTED TO: A100779C=2289129
2 PLC ±0.15		WEIGHT: CUSTOMER DRAWING	SCALE: 4:1 SHEET 2 OF 6 REV E
3 PLC ±			
4 PLC ±			
ANGLES ±			
FINISH: SEE NOTE 1			
SEE NOTE 2			

REVISIONS				
P.	LTN.	DESCRIPTION	DATE	APVD.
-	-	SEE SHEET 1	-	-

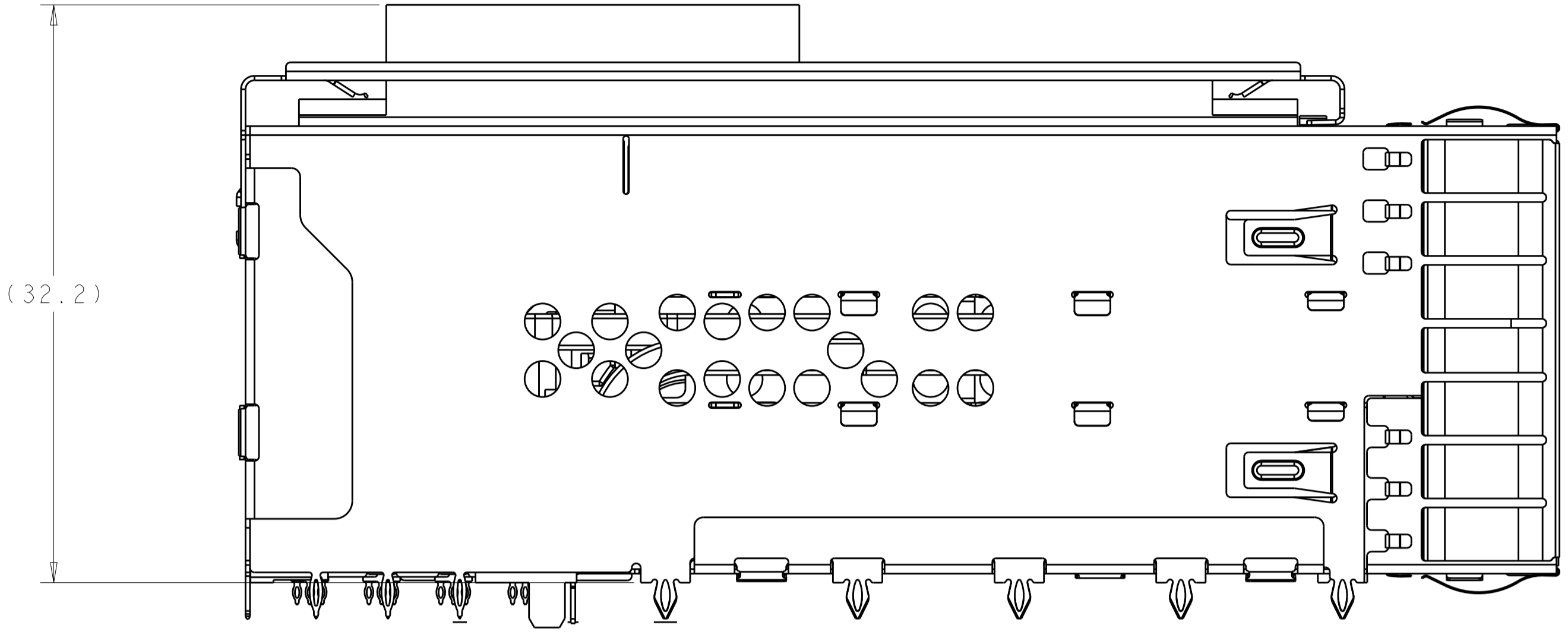

1-2289129-3  
SCALE 4:1

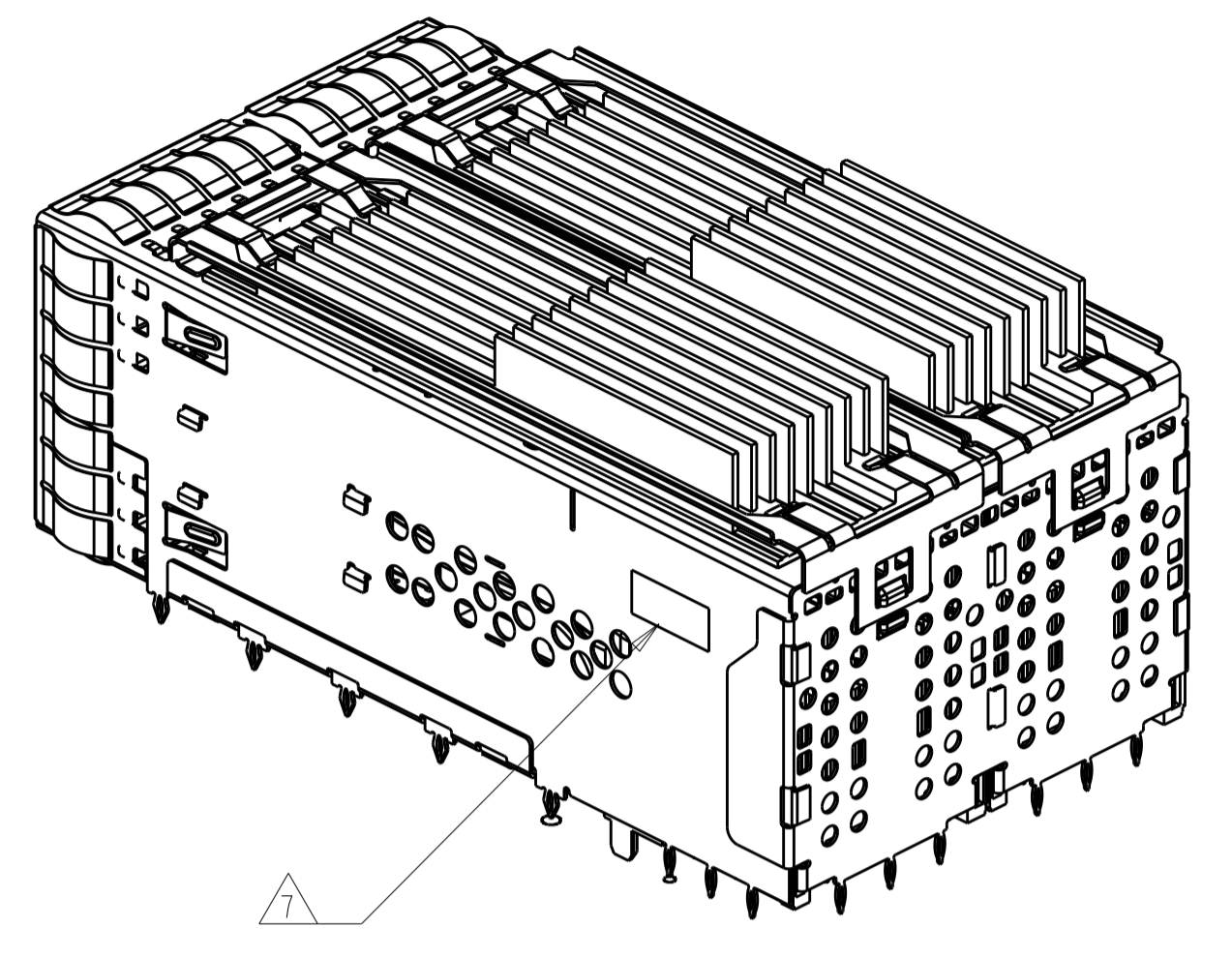
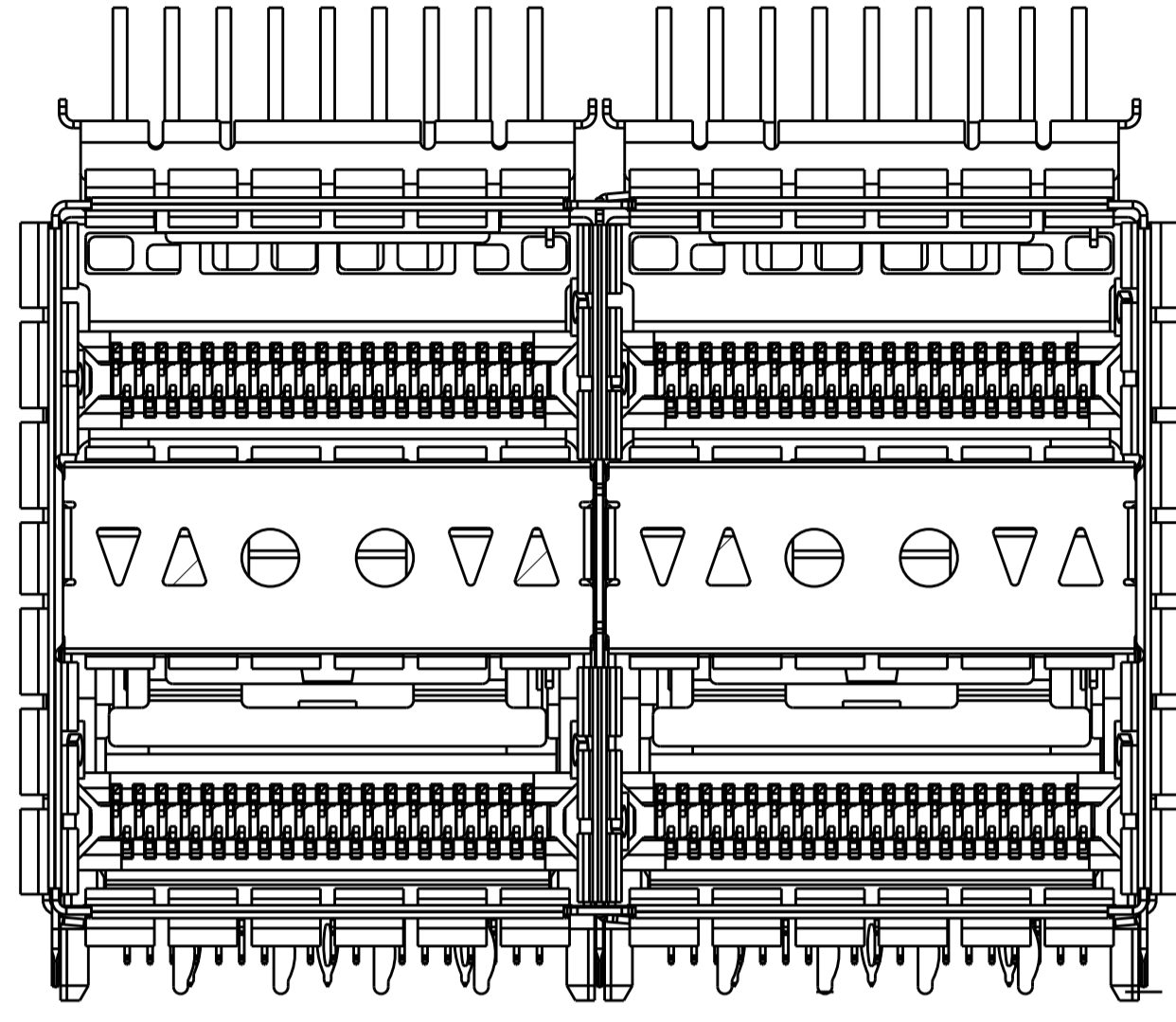

1-2289129-3  
SCALE 2:1

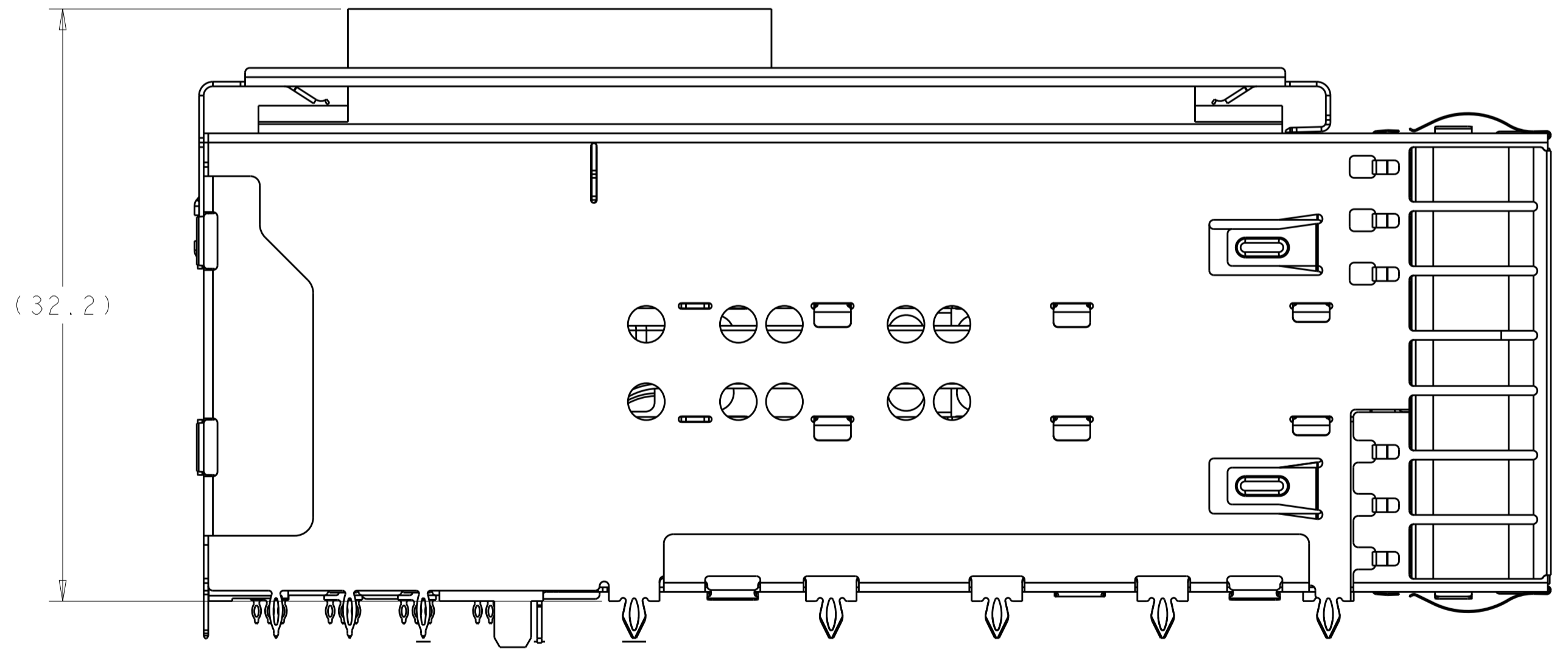

1-2289129-1  
SCALE 4:1

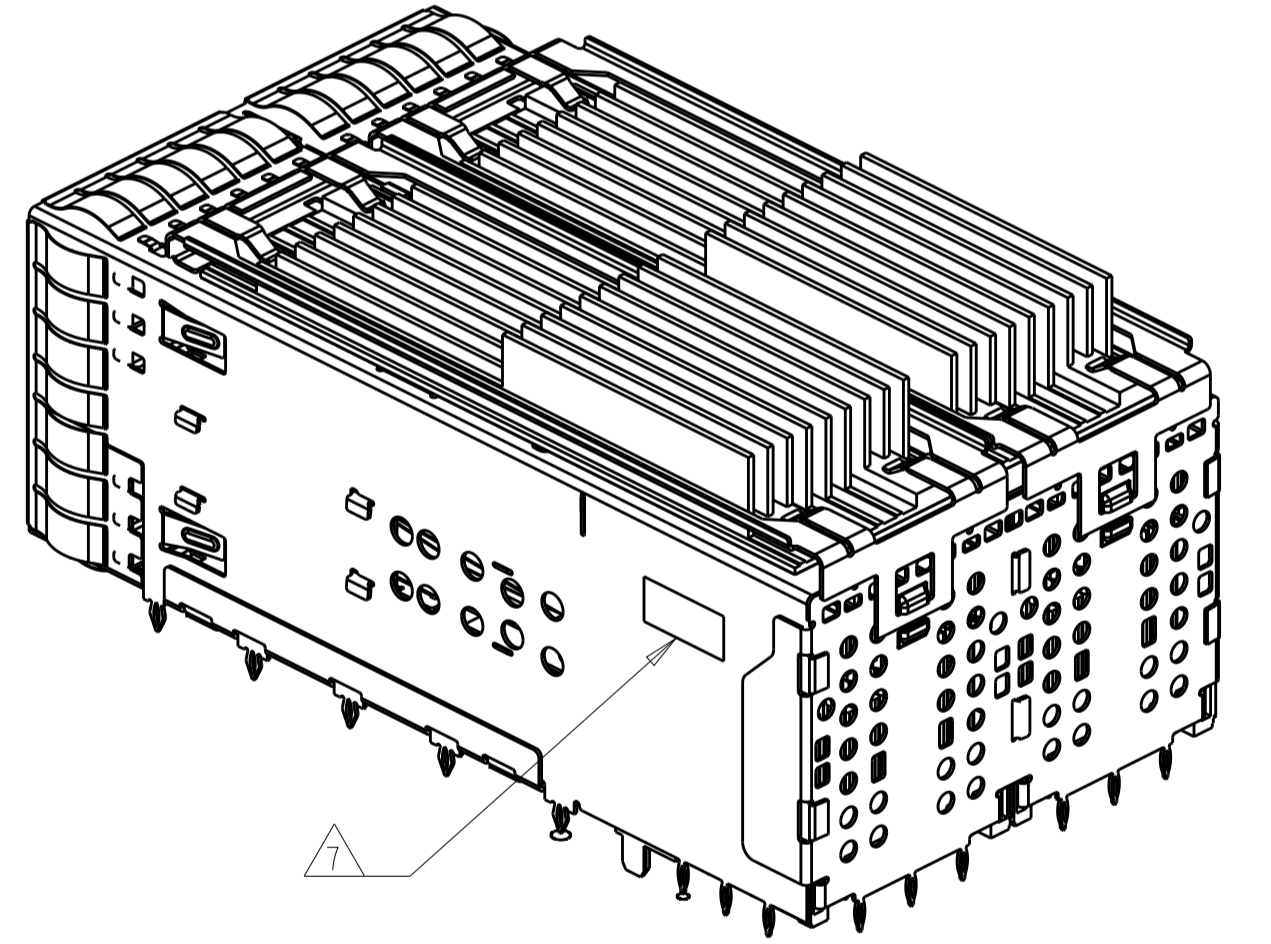
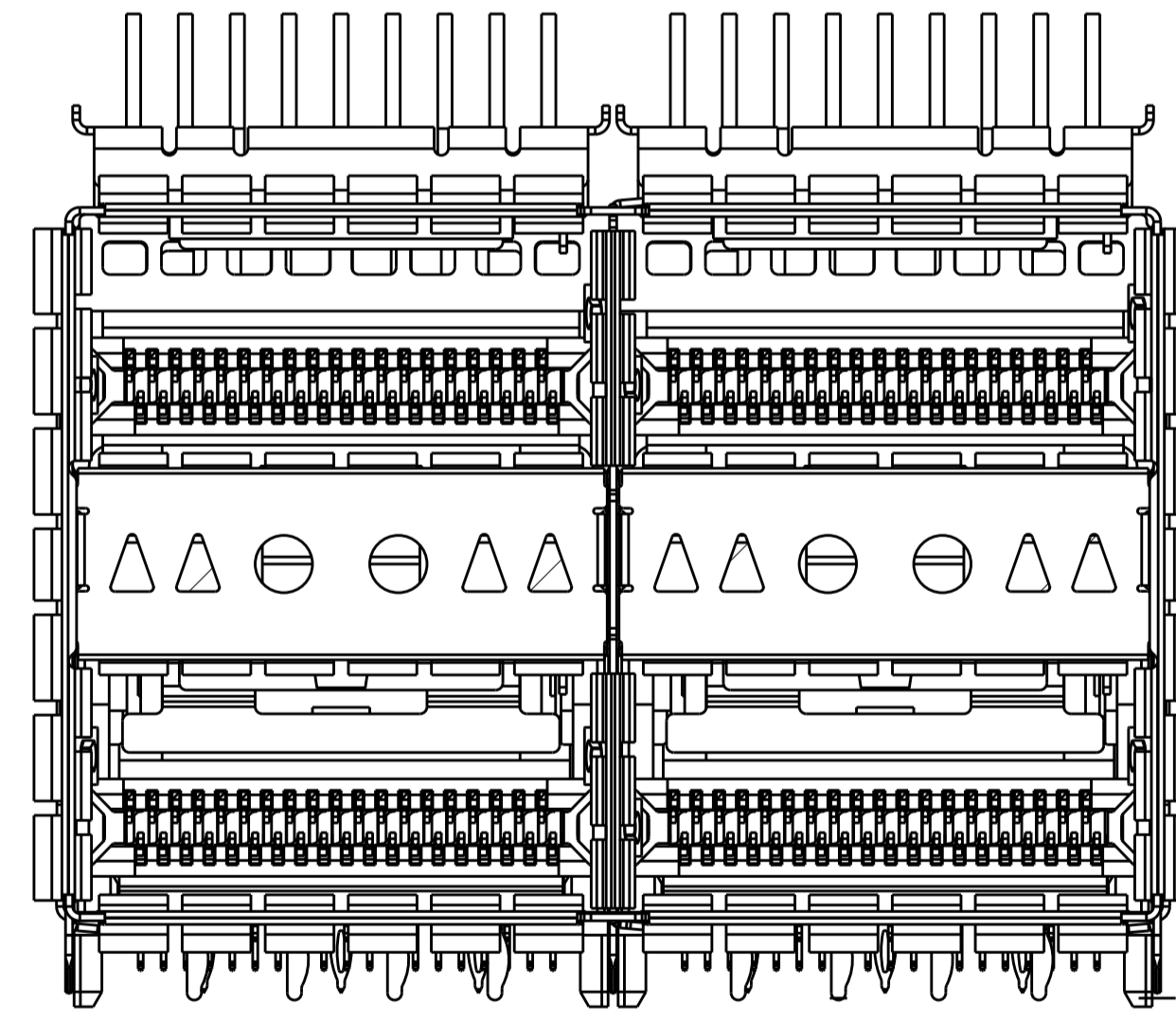

1-2289129-1  
SCALE 2:1

THIS DRAWING IS A CONTROLLED DOCUMENT.		DWN: TIM XUE 30NOV2014	
DIMENSIONS: mm		CHK: JASON YANG 30NOV2014	
		APVD: JASON YANG 30NOV2014	NAME: ZOSFP+ 2X2 WITH EMI SPRING FINGERS 4 INTERNAL LIGHT PIPES
TOLERANCES UNLESS OTHERWISE SPECIFIED:		PRODUCT SPEC: 108-60102	SIZE: A1
0 PLC ±		APPLICATION SPEC: 114-60015	CAGE CODE: C=2289129
1 PLC ±0.25		WEIGHT: -	RESTRICTED TO: -
2 PLC ±0.15		FINISH: -	SCALE: 4:1
3 PLC ±		MATERIAL: -	SHEET 3 OF 6
4 PLC ±		SEE NOTE 1	REV E
ANGLES ±		SEE NOTE 2	
MATERIAL: -		CUSTOMER DRAWING	

REVISIONS				
P.	LTN.	DESCRIPTION	DATE	APVD.
-	-	SEE SHEET 1	-	-

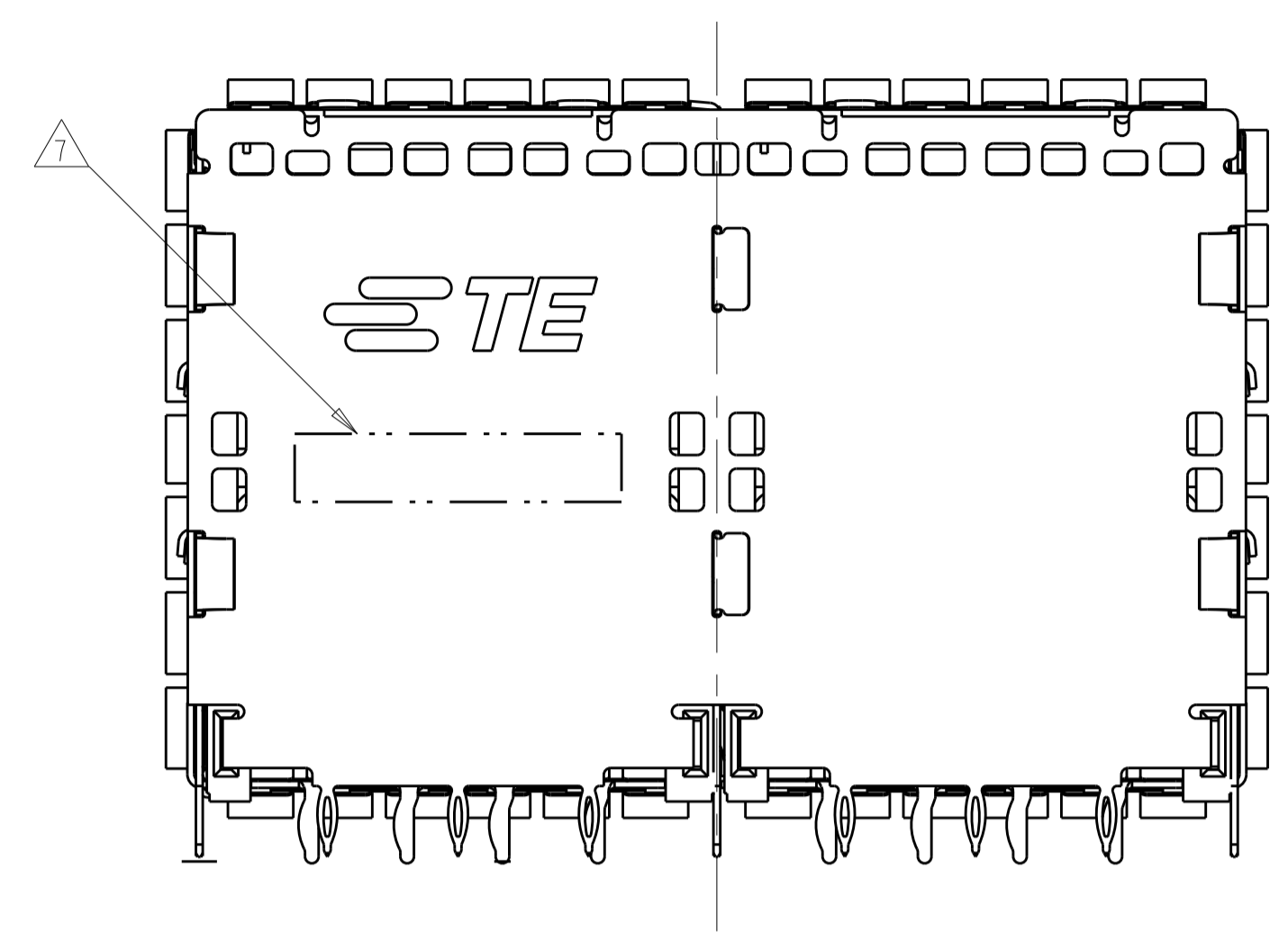

VIEW Y-Y

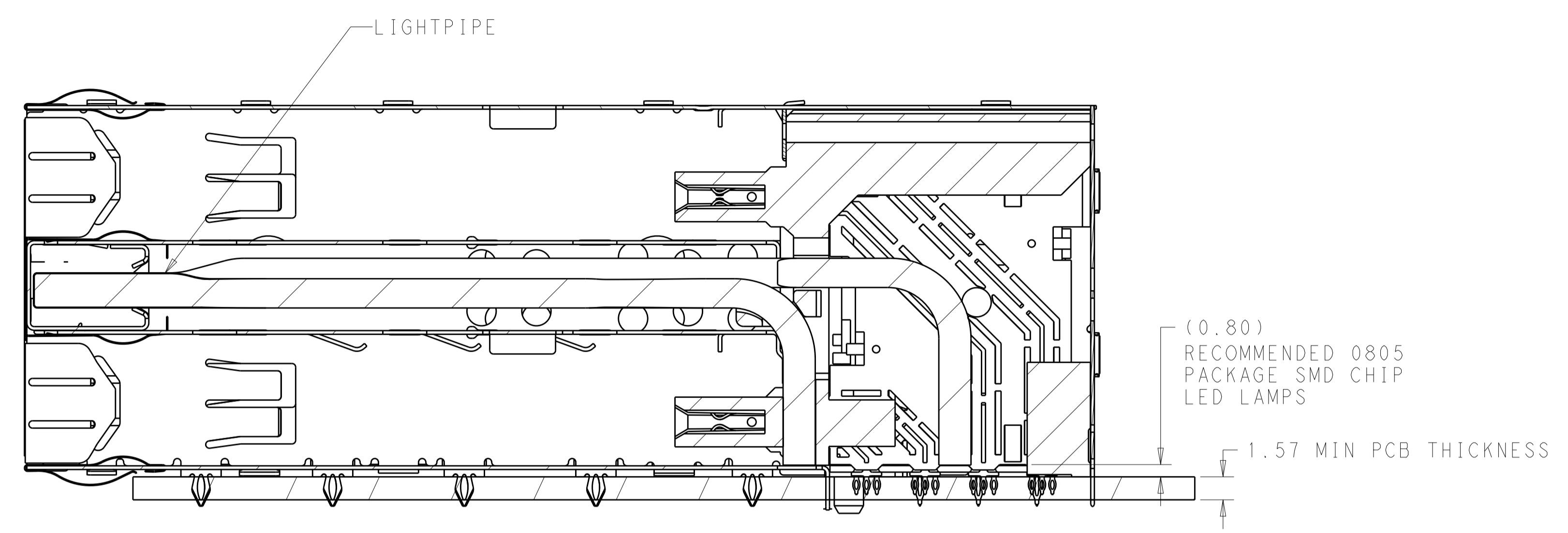

SECTION V-V  
SCALE 4:1

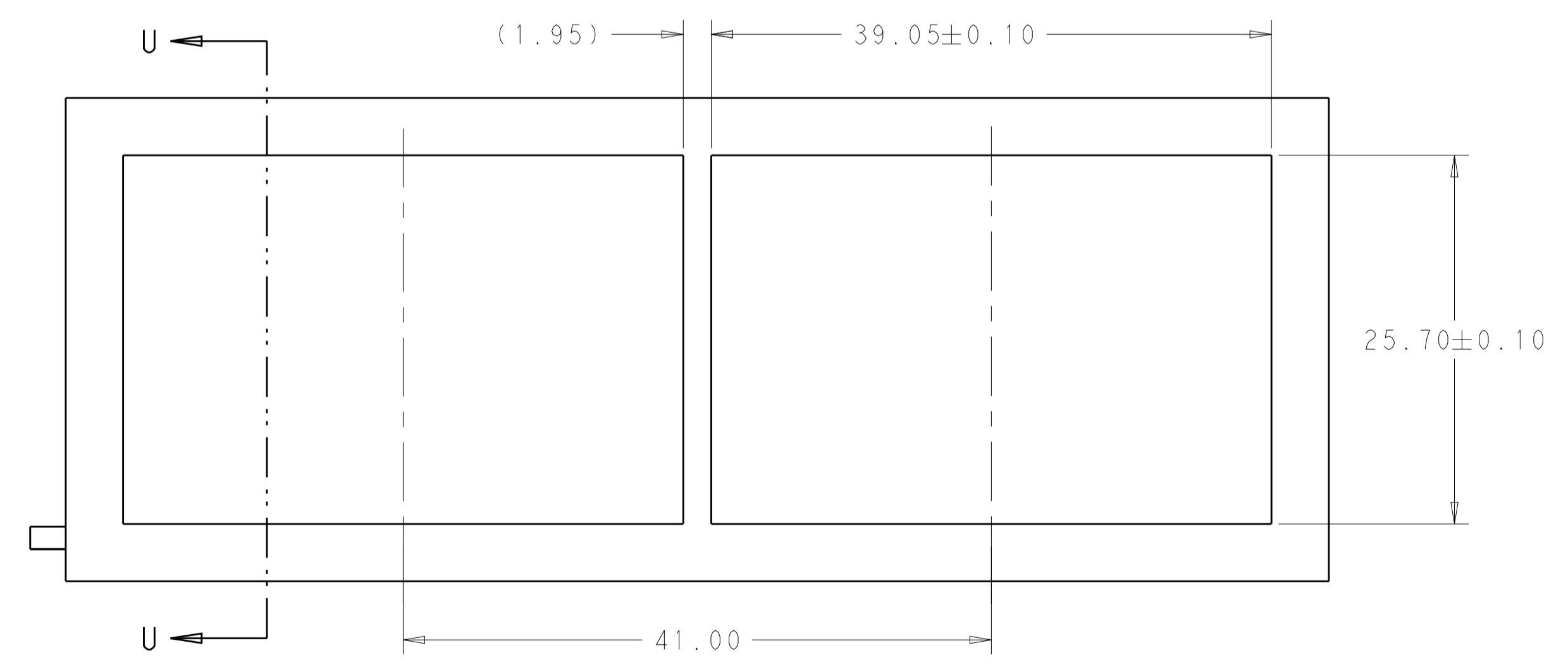

RECOMMENDED PANEL CUTOUT  
AND PC BOARD, PANEL POSITION  
SCALE 3:1

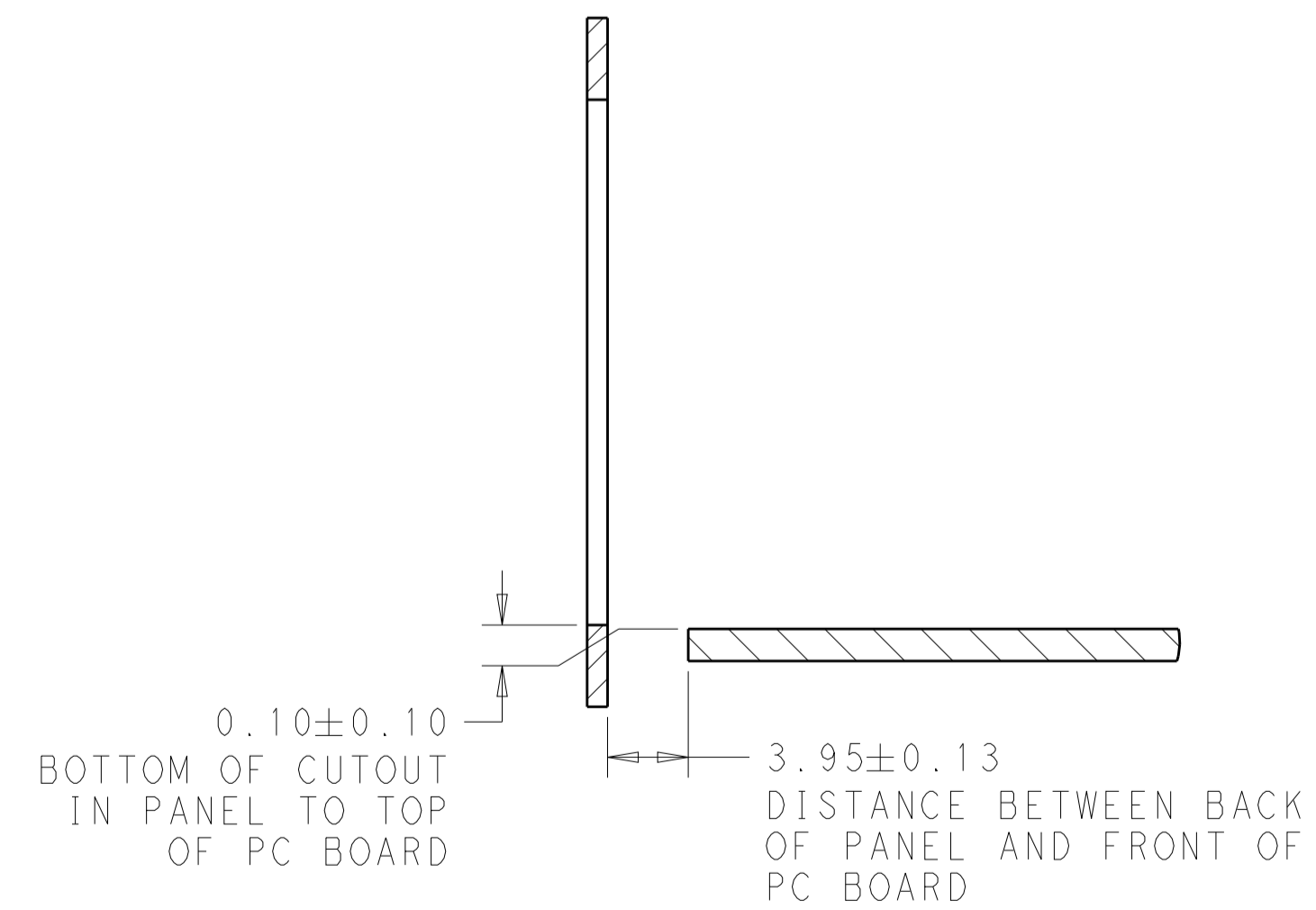

SECTION U-U

THIS DRAWING IS A CONTROLLED DOCUMENT.		OWN: TIM XUE 30NOV2014	TE Connectivity
DIMENSIONS: mm		CHK: JASON YANG 30NOV2014	
TOLERANCES UNLESS OTHERWISE SPECIFIED:		APVD: JASON YANG 30NOV2014	NAME: ZOSFP+ 2X2 WITH EMI SPRING FINGERS 4 INTERNAL LIGHT PIPES
0 PLC ±	1 PLC ±0.25	PRODUCT SPEC: 108-60102	SIZE: A1
2 PLC ±0.15	3 PLC ±	APPLICATION SPEC: 114-60015	CAGE CODE: 2289129
4 PLC ±	ANGLES ±	WEIGHT: -	RESTRICTED TO: -
MATERIAL: -	FINISH: -	CUSTOMER DRAWING	SCALE: 4:1 SHEET: 4 OF 6 REV: E
SEE NOTE 1	SEE NOTE 2		

REVISIONS				
P.	LTN.	DESCRIPTION	DATE	APP'D.
-	-	SEE SHEET 1	-	-

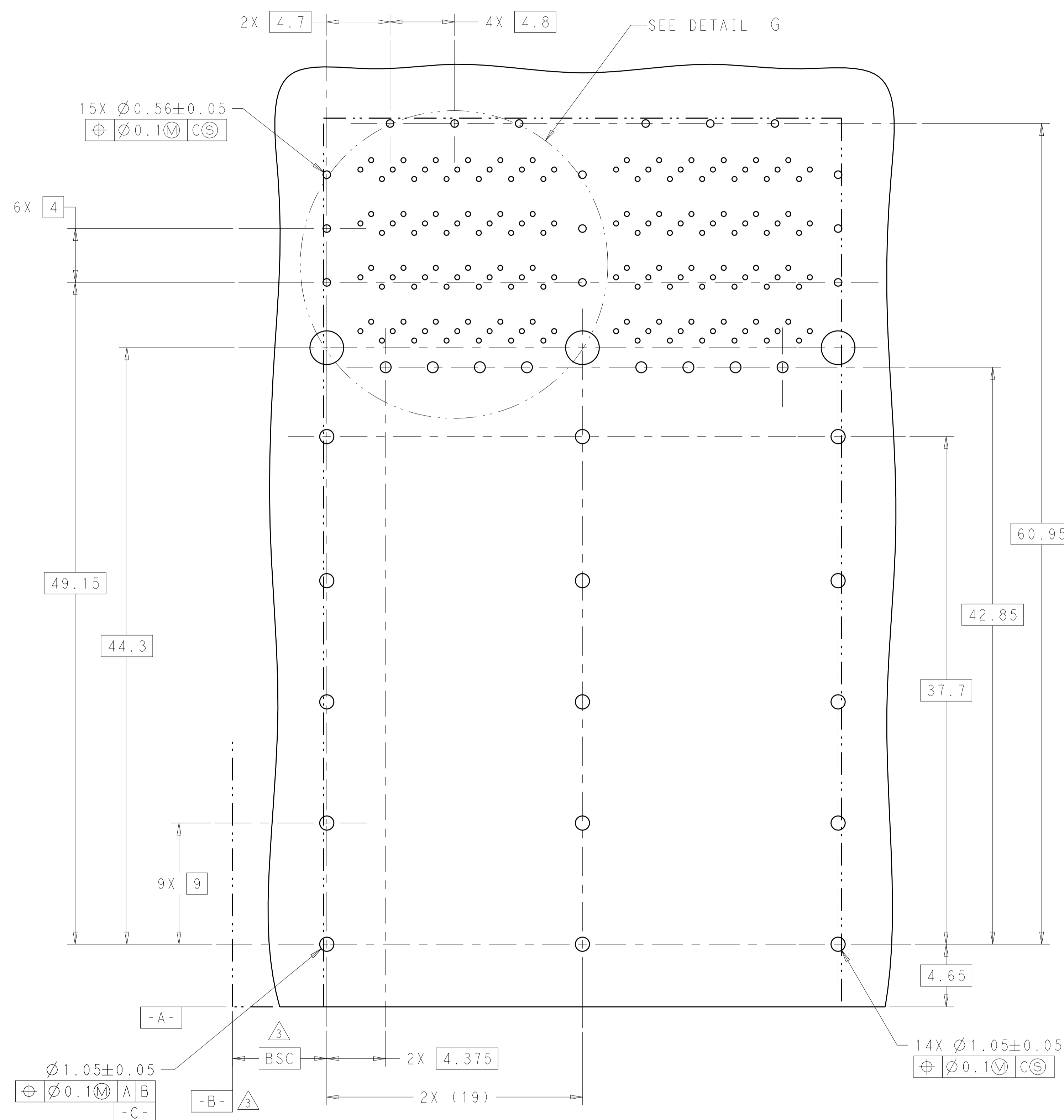

RECOMMENDED PC BOARD LAYOUT  
COMPONENT SIDE OF BOARD  
(PCB TOLERANCE ±0.05)  
SCALE 5:1

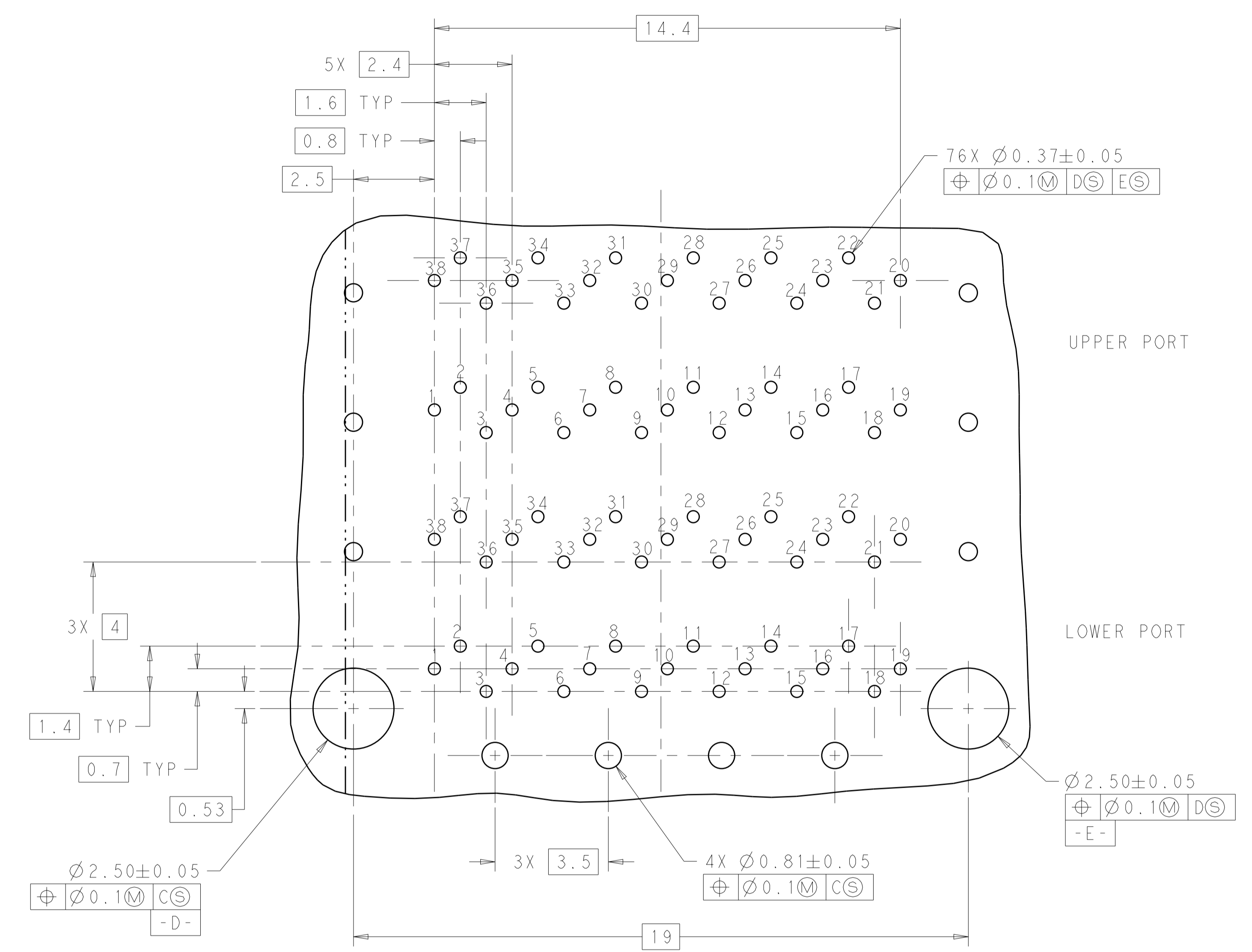

DETAIL G  
SCALE 10:1

THIS DRAWING IS A CONTROLLED DOCUMENT.		DWN: TIM XUE 30NOV2014 CHN: JASON YANG 30NOV2014 APVD: JASON YANG 30NOV2014	TE Connectivity
DIMENSIONS: mm		PRODUCT SPEC: 108-60102 APPLICATION SPEC: 114-60015	
TOLERANCES UNLESS OTHERWISE SPECIFIED:		0 PLC ±0.25 1 PLC ±0.15 2 PLC ±0.15 3 PLC ±0.15 4 PLC ±0.15 ANGLES ±0.15	RESTRICTED TO: - SCALE: 1:1 SHEET: 5 OF 6 REV: E
MATERIAL: SEE NOTE 1		FINISH: SEE NOTE 2	
CUSTOMER DRAWING			

REVISIONS				
P.	LTN.	DESCRIPTION	DATE	APPD.
-	-	SEE SHEET 1	-	-

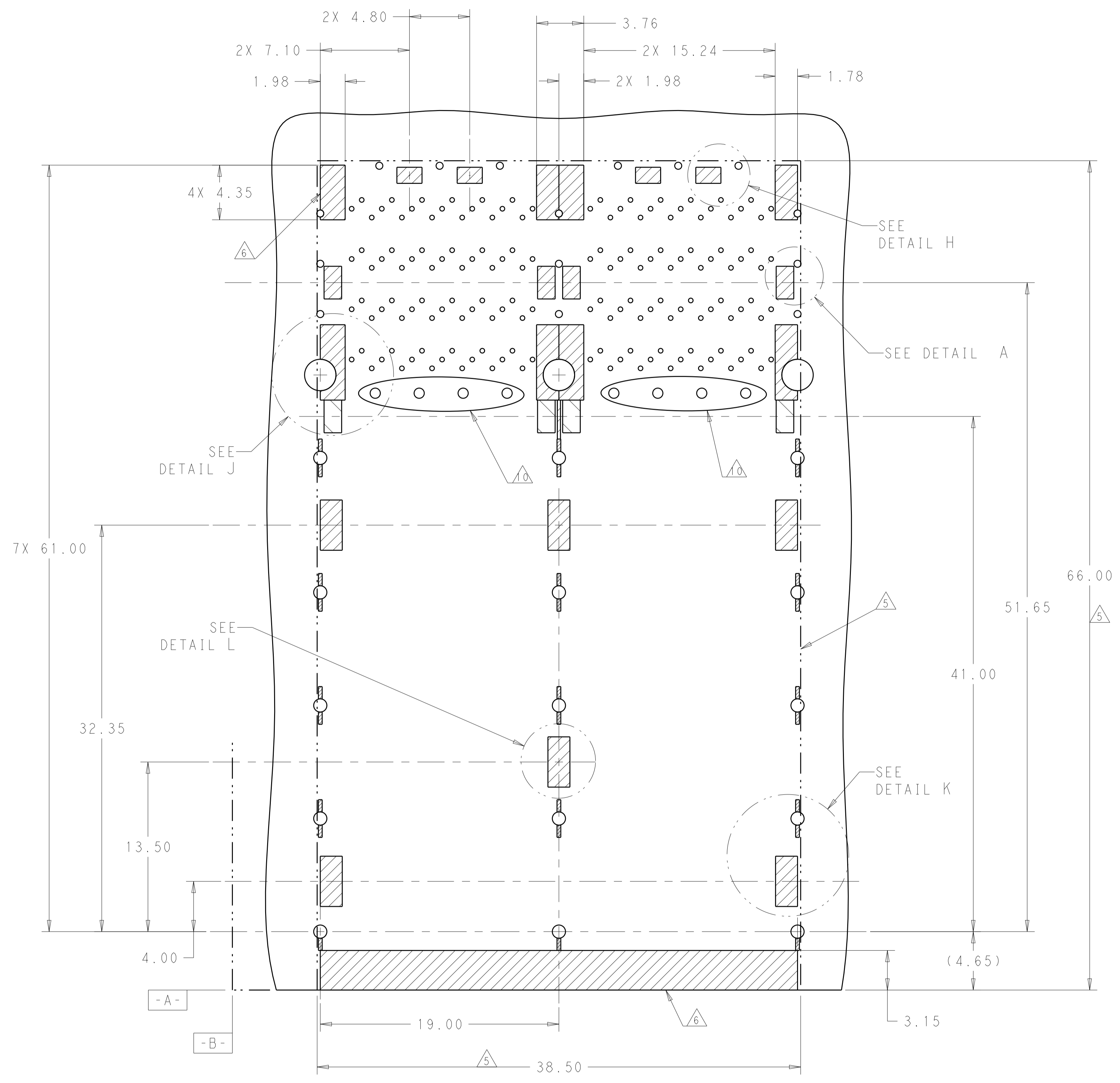

KEEPOUT AREAS  
COMPONENT SIDE OF BOARD  
(PCB TOLERANCE ±0.05)  
SCALE 5:1

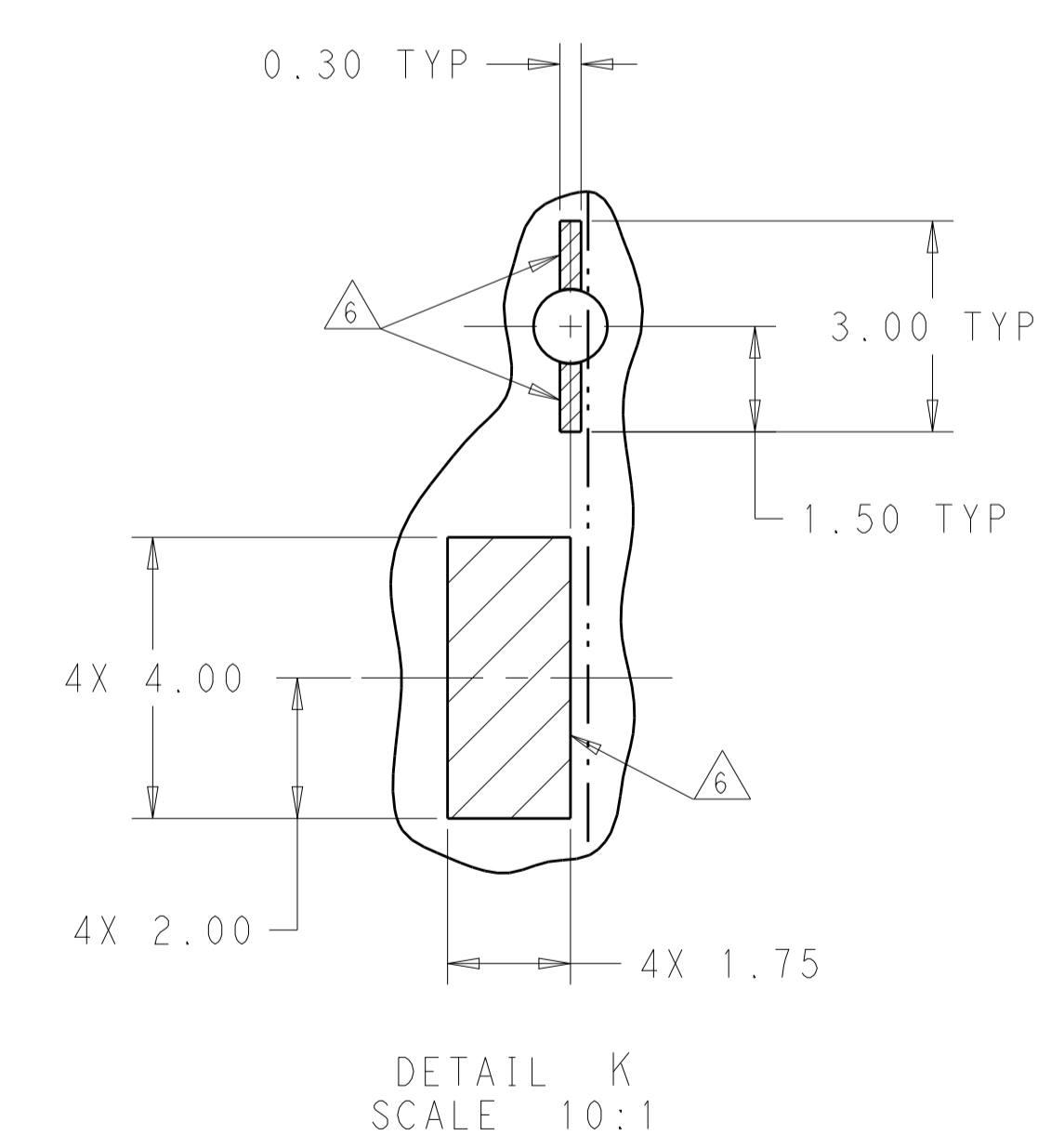
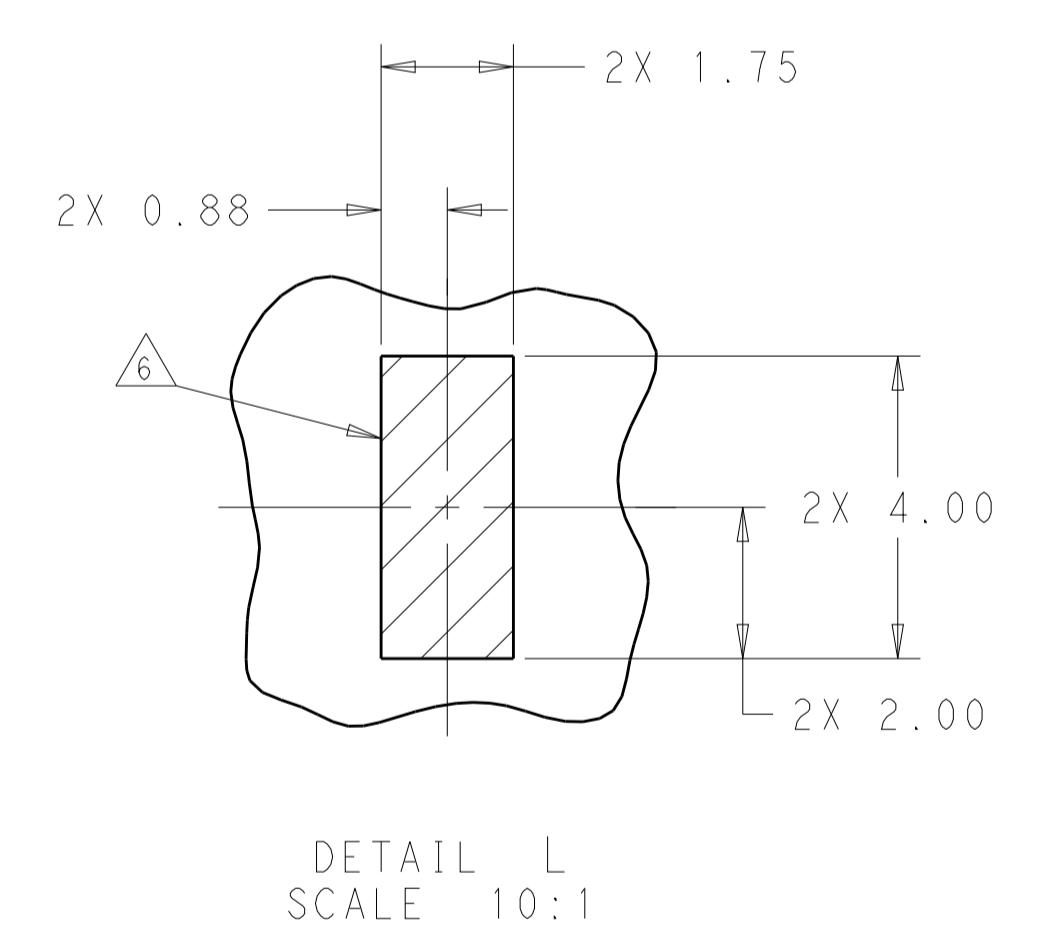
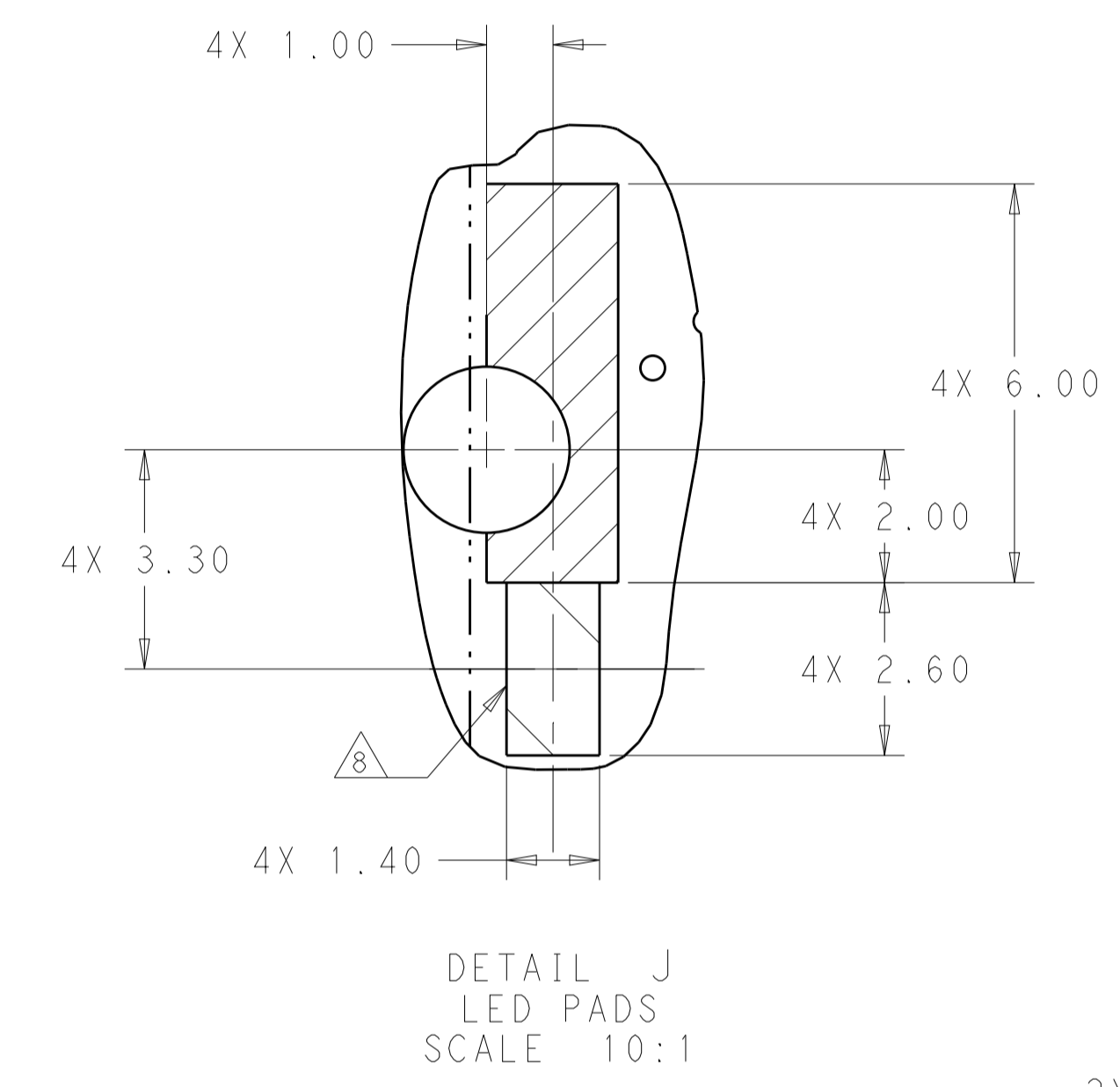
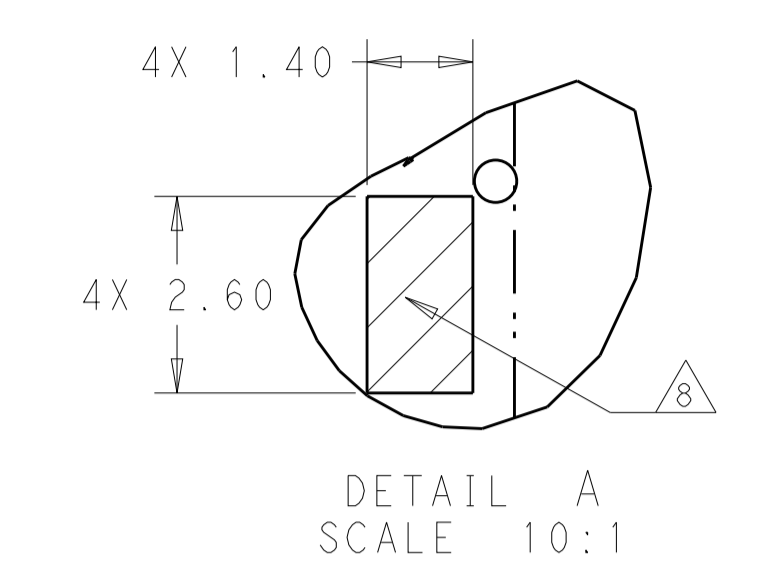
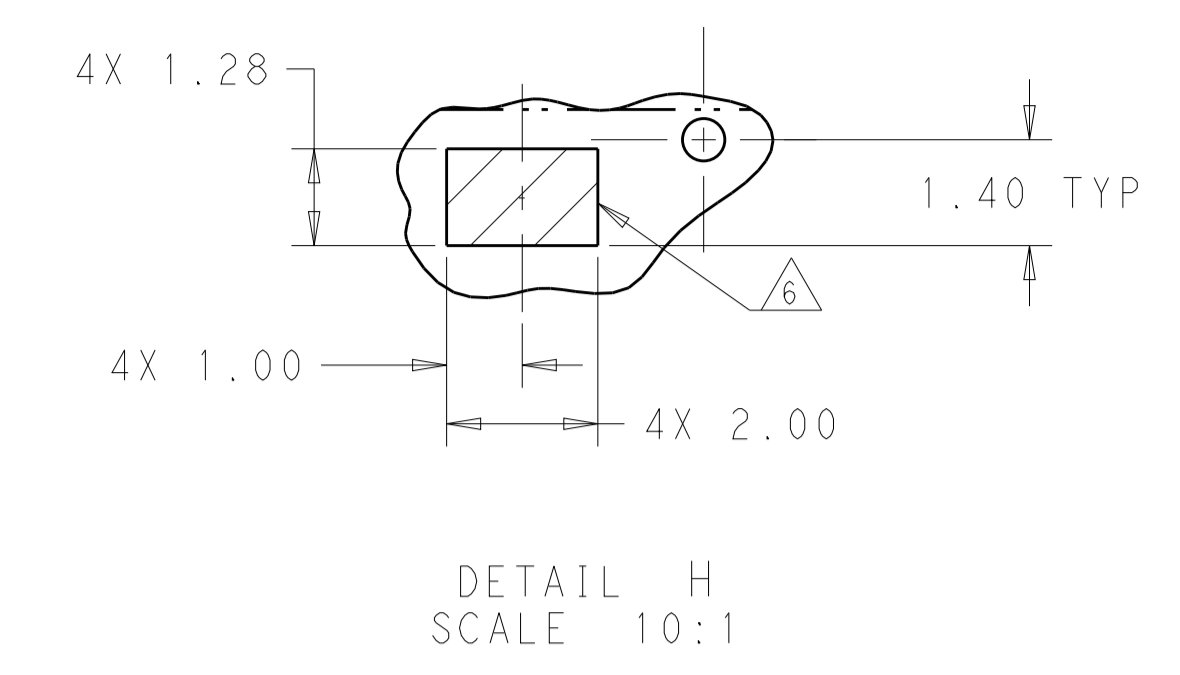

THIS DRAWING IS A CONTROLLED DOCUMENT.		OWN: TIM XUE 30NOV2014	 TE Connectivity
DIMENSIONS: mm		CHK: JASON YANG 30NOV2014	
TOLERANCES UNLESS OTHERWISE SPECIFIED:		APVD: JASON YANG 30NOV2014	NAME: ZOSFP+ 2X2 WITH EMI SPRING FINGERS 4 INTERNAL LIGHT PIPES
0 PLC ±0.25	1 PLC ±0.15	PRODUCT SPEC: 108-60102	SIZE: 114-60015
2 PLC ±0.15	3 PLC ±0.15	APPLICATION SPEC: 114-60015	RESTRICTED TO: A100779C=2289129
4 PLC ±0.15	ANGLES ±0.15	WEIGHT: -	SCALE: 1:1 SHEET 6 OF 6 REV E
MATERIAL: -	FINISH: -	CUSTOMER DRAWING	