

250 V to 600 V, 1.5 A to 2.5 A
High Voltage 3-phase Motor Driver ICs
SLA/SMA6820MH Series



Data Sheet

Description

SLA/SMA6820MH series are high voltage 3-phase motor driver ICs in which transistors, pre-driver ICs (MICs), and bootstrap circuits (diodes and resistors) are highly integrated.

You can select from the fully-molded type or the heatsink-type ZIP24 package according to your mounting condition.

SLA/SMA6820MH series are optimal for the inverting control of small to middle power motors.

Features

- Built-in Bootstrap Diodes with Current Limiting Resistors (22 Ω)
- CMOS-compatible Input (3.3 or 5 V)
- Fault Signal Output (FO pin)
- 7.5 V Regulator Output
- Bare lead frame: Pb-free (RoHS compliant)
- Protections
 - Undervoltage Lockout for Power Supply
 - High-side (UVLO_VB): Auto-restart
 - Low-side (UVLO_VCC): Auto-restart
 - Thermal Detection (TD): Fault Signal Output

Packages

ZIP24
 Fully Molded Type
 (SMA682xMH)

Heatsink Type
 (SLA6826MH)



LF No. 2451



LF No. 2175



LF No. 2452

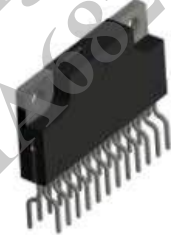

LF No. 2171
 Not to scale

Typical Application

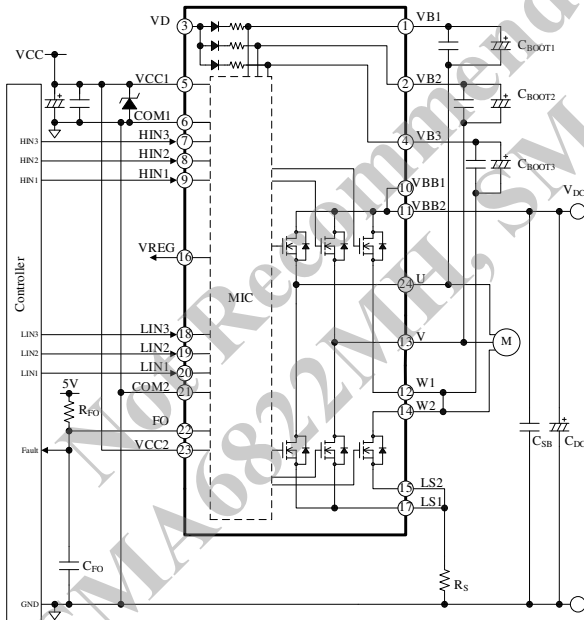

Selection Guide

● Packages

Package	Part Number
Fully Molded Type	SMA682xMH
Heatsink Type	SLA6826MH

● Output Characteristic

V _{DSS}	I _O	Part Number
250 V	2.0 A	SLA6826MH
		SMA6821MH
500 V	1.5 A	SMA6822MH
	2.5 A	SMA6823MH
600 V	1.5 A	SMA6824MH

Applications

- Washing Machine Fan Motor and Pump Motor
- Air Conditioner Fan Motor
- Air Cleaner Fan Motor
- Fan Motor for Electric Stand Fan

Contents

Description	1
Contents	2
1. Absolute Maximum Ratings.....	3
2. Recommended Operating Conditions	4
3. Electrical Characteristics	4
3.1. Characteristics of Control Parts.....	4
3.2. Bootstrap Diode Characteristics	5
3.3. Thermal Resistance Characteristics	5
3.4. Transistor Characteristics.....	6
3.4.1. SLA6826MH	6
3.4.2. SMA6821MH.....	7
3.4.3. SMA6822MH.....	7
3.4.4. SMA6823MH.....	8
3.4.5. SMA6824MH.....	8
4. Truth Table.....	9
5. Block Diagram	10
6. Pin Configuration Definitions.....	11
7. Typical Application	12
8. Timing Chart in Protection Operation.....	13
9. Physical Dimensions	15
9.1. ZIP24 (Fully Molded Type)	15
9.2. ZIP24 (Heatsink Type)	16
10. Marking Diagrams	17
10.1. ZIP24 (Full Molded Type).....	17
10.2. ZIP24 (Heatsink Type).....	17
Important Notes.....	18

Not Recommended for New Designs!
SMA6822MH, SMA6823MH, SMA6824MH

SLA/SMA6820MH Series

1. Absolute Maximum Ratings

Current polarities are defined as follows: a current flow going into the IC (sinking) is positive current (+); and a current flow coming out of the IC (sourcing) is negative current (-).

Unless specifically noted, $T_A = 25^\circ\text{C}$, COM1 = COM2 that is called COM.

Characteristic	Symbol	Conditions	Rating	Unit	Remarks
MOSFET Breakdown Voltage	V_{DSS}	$I_D = 100 \mu\text{A}$ $V_{INx} = 0 \text{ V}$	250	V	SLA6826MH SMA6821MH
			500		SMA6822MH SMA6823MH
			600		SMA6824MH
Logic Supply Voltage	V_{CC}	VCC1-COM VCC2-COM	20	V	
Bootstrap Supply Voltage	V_{BS}	VB1-U VB2-V VB3-W1	20	V	
Output Current (DC)	I_O	$T_C = 25^\circ\text{C}$	1.5	A	SMA6822MH SMA6824MH
			2.0		SLA6826MH SMA6821MH
			2.5		SMA6823MH
Output Current (Pulse)	I_{OP}	$T_C = 25^\circ\text{C}$, $P_W \leq 100 \mu\text{s}$, Duty = 1%	2.25	A	SMA6822MH SMA6824MH
			3.0		SLA6826MH SMA6821MH
			3.75		SMA6823MH
Regulator Output Current	I_{REG}		35	mA	
Input Voltage	V_{IN}	HIN1-COM HIN2-COM HIN3-COM LIN1-COM LIN2-COM LIN3-COM	-0.5 to 7	V	
Power Dissipation	P_D	$T_C = 25^\circ\text{C}$	28	W	SMA682xMH
			32		SLA6826MH
Operating Case Temperature	$T_{C(OP)}$		-30 to 100	$^\circ\text{C}$	
Junction Temperature	T_j		150	$^\circ\text{C}$	
Storage Temperature	T_{stg}		-40 to 150	$^\circ\text{C}$	

SLA/SMA6820MH Series

2. Recommended Operating Conditions

Unless specifically noted, $T_A = 25^\circ\text{C}$, COM1 = COM2 that is called COM.

Characteristic	Symbol	Conditions	Min.	Typ.	Max.	Unit	Remarks
Main Supply Voltage	V_{DC}	VBB-LS1 VBB-LS2	—	150	200	V	SLA6826MH SMA6821MH
			—	300	400	V	SMA6822MH SMA6823MH
			—	300	450	V	SMA6824MH
Logic Supply Voltage	V_{CC}	VCC1-COM VCC2-COM	13.5	—	16.5	V	
Dead Time of Input Signal	t_{DEAD}	$T_J = -25$ to 150°C	1.5	—	—	Ms	
Minimum Input Pulse Width	$t_{IN_MIN(ON)}$	$T_J = -25$ to 150°C	0.5	—	—	μs	
	$t_{IN_MIN(OFF)}$	$T_J = -25$ to 150°C	0.5	—	—	μs	

3. Electrical Characteristics

Current polarities are defined as follows: a current flow going into the IC (sinking) is positive current (+); and a current flow coming out of the IC (sourcing) is negative current (-).

Unless specifically noted, $V_{CC} = 15\text{ V}$, $T_A = 25^\circ\text{C}$, COM1 = COM2 that is called COM.

3.1. Characteristics of Control Parts

Characteristic	Symbol	Conditions	Min.	Typ.	Max.	Unit	Remarks
Logic Supply Current	I_{CC}	$I_{REG} = 0\text{ A}$	—	4	6	mA	
Input Voltage	V_{IH}		—	2.0	2.5	V	All transistors on state.
	V_{IL}		1.0	1.5	—	V	All transistors off state.
	V_{HYS}		—	0.5	—	V	
Input Current	I_{IH}	$I_{N_x} = 5\text{ V}$	—	50	100	μA	
	I_{IL}	$I_{N_x} = 0\text{ V}$	—	—	2	μA	
Undervoltage Lockout for Power Supply (High side)	V_{UVHL}	VB1-U	9.0	10.0	11.0	V	
	V_{UVHH}	VB2-V	9.5	10.5	11.5	V	
	V_{UV_HYS}	VB3-W1	—	0.5	—	V	
Undervoltage Lockout for Power Supply (Low side)	V_{UVLL}	VCC1-COM	10.0	11.0	12.0	V	
	V_{UVLH}	VCC2-COM	10.5	11.5	12.5	V	
	V_{UV_HYS}		—	0.5	—	V	
FO Pin Output Voltage	V_{FOL}		0	—	1.0	V	
	V_{FOH}		4.0	—	5.5	V	
Thermal Detection Threshold Temperature	T_{DH}	$I_{REG} = 0\text{ mA}$, No heatsink	135	150	165	$^\circ\text{C}$	
	T_{DL}		105	120	135	$^\circ\text{C}$	
	T_{D_HYS}		—	30	—	$^\circ\text{C}$	
Regulator Output Voltage	V_{REG}	$I_{REG} = 0$ to 35 mA	6.75	7.5	8.25	V	

SLA/SMA6820MH Series

3.2. Bootstrap Diode Characteristics

Characteristic	Symbol	Conditions	Min.	Typ.	Max.	Unit	Remarks
Bootstrap Diode Forward Voltage	V_{FB}	$I_{FB} = 0.15 \text{ A}$	—	1.1	1.3	V	
Bootstrap Diode Leakage Current	I_{LBD}	$V_R = 250 \text{ V}$	—	—	10	μA	SLA6826MH SMA6821MH
		$V_R = 500 \text{ V}$	—	—	10		SMA6822MH SMA6823MH
		$V_R = 600 \text{ V}$	—	—	10		SMA6824MH
Bootstrap Diode Series Resistor	R_B		17.6	22.0	26.4	Ω	

3.3. Thermal Resistance Characteristics

Characteristic	Symbol	Conditions	Min.	Typ.	Max.	Unit	Remarks
Junction-to-Case Thermal Resistance	R_{J-C}	All transistors operation	—	—	4.46	$^{\circ}\text{C/W}$	SMA682xMH
			—	—	3.8		SLA6826MH
Junction-to-Ambient Thermal Resistance	R_{J-A}	All transistors operation	—	—	31.25	$^{\circ}\text{C/W}$	SMA682xMH

3.4. Transistor Characteristics

Figure 3-1 shows the definition of switching characteristics.

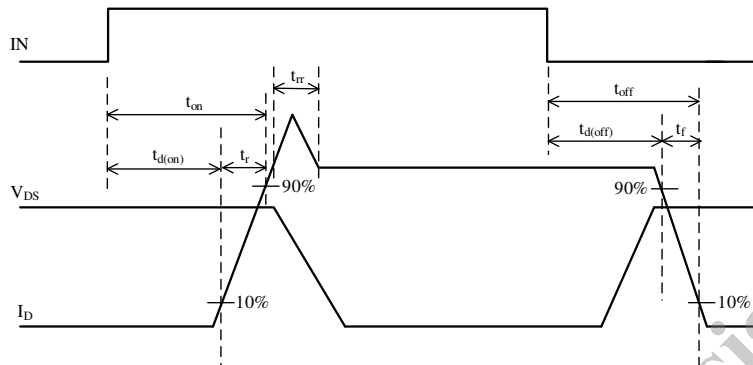

Figure 3-1. Switching Characteristics Definitions

3.4.1. SLA6826MH

Characteristic	Symbol	Conditions	Min.	Typ.	Max.	Unit
Drain-to-Source Leakage Current	I_{DSS}	$V_{DS} = 250 \text{ V}, V_{IN} = 0 \text{ V}$	—	—	100	μA
Drain-to-Source Saturation Voltage	$R_{DS(ON)}$	$I_D = 1.0 \text{ A}, V_{IN} = 5 \text{ V}$	—	1.25	1.5	Ω
Source-to-Drain Diode Forward Voltage	V_{SD}	$I_{SD} = 1.0 \text{ A}, V_{IN} = 0 \text{ V}$	—	1.1	1.5	V
High-side Switching						
Source-to-Drain Diode Reverse Recovery Time	t_{rr}	$V_{DC} = 150 \text{ V}, I_D = 2.0 \text{ A}, V_{IN} = 0 \sim 5 \text{ V}, T_J = 25 \text{ }^\circ\text{C},$ inductive load	—	65	—	ns
Turn-on Delay Time	$t_{d(on)}$		—	430	—	ns
Rise Time	t_r		—	55	—	ns
Turn-off Delay Time	$t_{d(off)}$		—	355	—	ns
Fall Time	t_f		—	20	—	ns
Low-side Switching						
Source-to-Drain Diode Reverse Recovery Time	t_{rr}	$V_{DC} = 150 \text{ V}, I_D = 2.0 \text{ A}, V_{IN} = 0 \sim 5 \text{ V}, T_J = 25 \text{ }^\circ\text{C},$ inductive load	—	65	—	ns
Turn-on Delay Time	$t_{d(on)}$		—	505	—	ns
Rise Time	t_r		—	60	—	ns
Turn-off Delay Time	$t_{d(off)}$		—	495	—	ns
Fall Time	t_f		—	20	—	ns

SLA/SMA6820MH Series

3.4.2. SMA6821MH

Characteristic	Symbol	Conditions	Min.	Typ.	Max.	Unit
Drain-to-Source Leakage Current	I_{DSS}	$V_{DS} = 250 \text{ V}, V_{IN} = 0 \text{ V}$	—	—	100	μA
Drain-to-Source Saturation Voltage	$R_{DS(ON)}$	$I_D = 1.0 \text{ A}, V_{IN} = 5 \text{ V}$	—	1.25	1.5	Ω
Source-to-Drain Diode Forward Voltage	V_{SD}	$I_{SD} = 1.0 \text{ A}, V_{IN} = 0 \text{ V}$	—	1.1	1.5	V
High-side Switching						
Source-to-Drain Diode Reverse Recovery Time	t_{rr}	$V_{DC} = 150 \text{ V}, I_D = 2.0 \text{ A}, V_{IN} = 0 \sim 5 \text{ V}, T_J = 25 \text{ }^\circ\text{C},$ inductive load	—	65	—	ns
Turn-on Delay Time	$t_{d(on)}$		—	430	—	ns
Rise Time	t_r		—	55	—	ns
Turn-off Delay Time	$t_{d(off)}$		—	355	—	ns
Fall Time	t_f		—	20	—	ns
Low-side Switching						
Source-to-Drain Diode Reverse Recovery Time	t_{rr}	$V_{DC} = 150 \text{ V}, I_D = 2.0 \text{ A}, V_{IN} = 0 \sim 5 \text{ V}, T_J = 25 \text{ }^\circ\text{C},$ inductive load	—	65	—	ns
Turn-on Delay Time	$t_{d(on)}$		—	505	—	ns
Rise Time	t_r		—	60	—	ns
Turn-off Delay Time	$t_{d(off)}$		—	495	—	ns
Fall Time	t_f		—	20	—	ns

3.4.3. SMA6822MH

Characteristic	Symbol	Conditions	Min.	Typ.	Max.	Unit
Drain-to-Source Leakage Current	I_{DSS}	$V_{DS} = 500 \text{ V}, V_{IN} = 0 \text{ V}$	—	—	100	μA
Drain-to-Source Saturation Voltage	$R_{DS(ON)}$	$I_D = 0.75 \text{ A}, V_{IN} = 5 \text{ V}$	—	3.2	4.0	Ω
Source-to-Drain Diode Forward Voltage	V_{SD}	$I_{SD} = 0.75 \text{ A}, V_{IN} = 0 \text{ V}$	—	1.1	1.5	V
High-side Switching						
Source-to-Drain Diode Reverse Recovery Time	t_{rr}	$V_{DC} = 300 \text{ V}, I_D = 1.5 \text{ A}, V_{IN} = 0 \sim 5 \text{ V}, T_J = 25 \text{ }^\circ\text{C},$ inductive load	—	120	—	ns
Turn-on Delay Time	$t_{d(on)}$		—	485	—	ns
Rise Time	t_r		—	85	—	ns
Turn-off Delay Time	$t_{d(off)}$		—	420	—	ns
Fall Time	t_f		—	30	—	ns
Low-side Switching						
Source-to-Drain Diode Reverse Recovery Time	t_{rr}	$V_{DC} = 300 \text{ V}, I_D = 1.5 \text{ A}, V_{IN} = 0 \sim 5 \text{ V}, T_J = 25 \text{ }^\circ\text{C},$ inductive load	—	130	—	ns
Turn-on Delay Time	$t_{d(on)}$		—	620	—	ns
Rise Time	t_r		—	100	—	ns
Turn-off Delay Time	$t_{d(off)}$		—	585	—	ns
Fall Time	t_f		—	25	—	ns

SLA/SMA6820MH Series

3.4.4. SMA6823MH

Characteristic	Symbol	Conditions	Min.	Typ.	Max.	Unit
Drain-to-Source Leakage Current	I_{DSS}	$V_{DS} = 500\text{ V}, V_{IN} = 0\text{ V}$	—	—	100	μA
Drain-to-Source Saturation Voltage	$R_{DS(ON)}$	$I_D = 1.25\text{ A}, V_{IN} = 5\text{ V}$	—	2.0	2.4	Ω
Source-to-Drain Diode Forward Voltage	V_{SD}	$I_{SD} = 1.25\text{ A}, V_{IN} = 0\text{ V}$	—	1.1	1.5	V
High-side Switching						
Source-to-Drain Diode Reverse Recovery Time	t_{rr}	$V_{DC} = 300\text{ V}, I_D = 2.5\text{ A}, V_{IN} = 0 \sim 5\text{ V}, T_J = 25\text{ }^\circ\text{C},$ inductive load	—	170	—	ns
Turn-on Delay Time	$t_{d(on)}$		—	700	—	ns
Rise Time	t_r		—	165	—	ns
Turn-off Delay Time	$t_{d(off)}$		—	580	—	ns
Fall Time	t_f		—	40	—	ns
Low-side Switching						
Source-to-Drain Diode Reverse Recovery Time	t_{rr}	$V_{DC} = 300\text{ V}, I_D = 2.5\text{ A}, V_{IN} = 0 \sim 5\text{ V}, T_J = 25\text{ }^\circ\text{C},$ inductive load	—	170	—	ns
Turn-on Delay Time	$t_{d(on)}$		—	800	—	ns
Rise Time	t_r		—	180	—	ns
Turn-off Delay Time	$t_{d(off)}$		—	690	—	ns
Fall Time	t_f		—	35	—	ns

3.4.5. SMA6824MH

Characteristic	Symbol	Conditions	Min.	Typ.	Max.	Unit
Drain-to-Source Leakage Current	I_{DSS}	$V_{DS} = 600\text{ V}, V_{IN} = 0\text{ V}$	—	—	100	μA
Drain-to-Source Saturation Voltage	$R_{DS(ON)}$	$I_D = 0.75\text{ A}, V_{IN} = 5\text{ V}$	—	2.9	3.5	Ω
Source-to-Drain Diode Forward Voltage	V_{SD}	$I_{SD} = 0.75\text{ A}, V_{IN} = 0\text{ V}$	—	1.0	1.5	V
High-side Switching						
Source-to-Drain Diode Reverse Recovery Time	t_{rr}	$V_{DC} = 300\text{ V}, I_D = 1.5\text{ A}, V_{IN} = 0 \sim 5\text{ V}, T_J = 25\text{ }^\circ\text{C},$ inductive load	—	155	—	ns
Turn-on Delay Time	$t_{d(on)}$		—	685	—	ns
Rise Time	t_r		—	115	—	ns
Turn-off Delay Time	$t_{d(off)}$		—	555	—	ns
Fall Time	t_f		—	55	—	ns
Low-side Switching						
Source-to-Drain Diode Reverse Recovery Time	t_{rr}	$V_{DC} = 300\text{ V}, I_D = 1.5\text{ A}, V_{IN} = 0 \sim 5\text{ V}, T_J = 25\text{ }^\circ\text{C},$ inductive load	—	155	—	ns
Turn-on Delay Time	$t_{d(on)}$		—	740	—	ns
Rise Time	t_r		—	130	—	ns
Turn-off Delay Time	$t_{d(off)}$		—	670	—	ns
Fall Time	t_f		—	35	—	ns

4. Truth Table

Table 4-1 is a truth table that provides the logic level definitions of operation modes.

In the case where HINx and LINx signals in each phase are high at the same time, both the high-side and low-side transistors are set on (simultaneous on-state). You must set the input signals so that the simultaneous on-state is not occurred.

After recovering from a UVLO_VCC condition, the high-side and low-side transistors resume switching according to the input logic levels of the next HINx and LINx signals (level-triggered).

After recovering from a UVLO_VB condition, the high-side transistors resume switching at the next rising edge of an HIN signal (edge-triggered).

Table 4-1. Truth Table for Operation Modes

Mode	HINx	LINx	High-side Transistors	Low-side Transistors
Normal Operation	L	L	OFF	OFF
	H	L	ON	OFF
	L	H	OFF	ON
	H	H	ON	ON
High-side Undervoltage Lockout for Power Supply (UVLO_VB)	L	L	OFF	OFF
	H	L	OFF	OFF
	L	H	OFF	ON
	H	H	OFF	ON
Low-side Undervoltage Lockout for Power Supply (UVLO_VCC)	L	L	OFF	OFF
	H	L	OFF	OFF
	L	H	OFF	OFF
	H	H	OFF	OFF
Thermal Detection (TD)	L	L	OFF	OFF
	H	L	ON	OFF
	L	H	OFF	ON
	H	H	ON	ON

5. Block Diagram

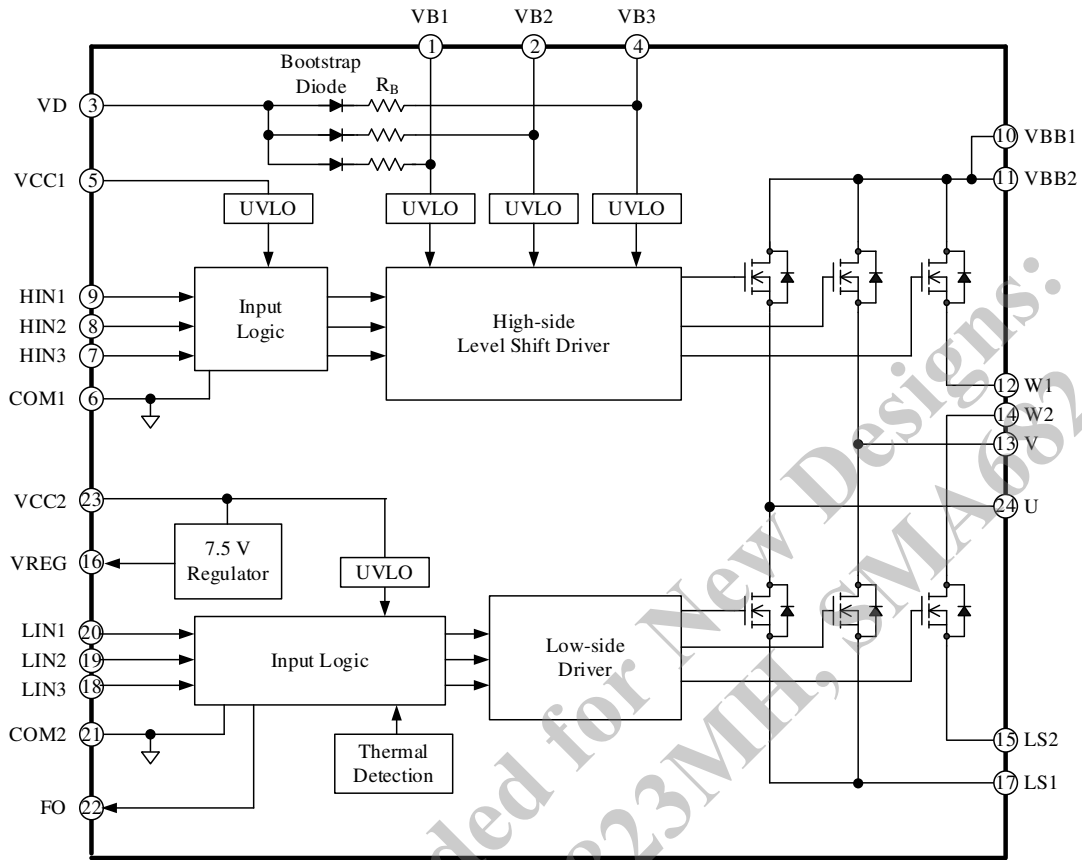

SLA/SMA6820MH Series

6. Pin Configuration Definitions

SMA682xMH

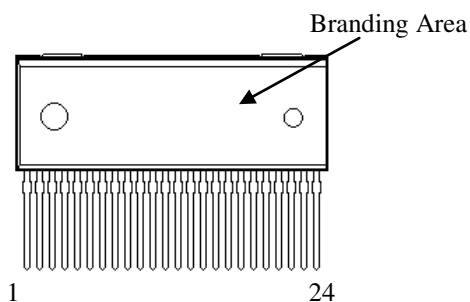

SLA6826MH

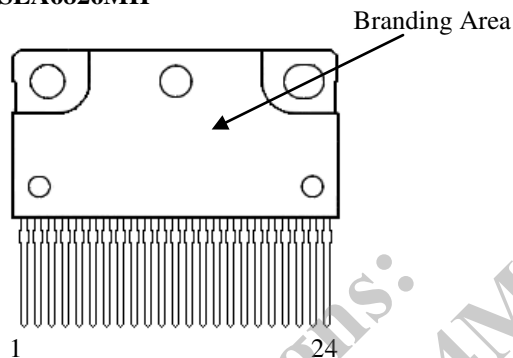

Pin Number	Pin Name	Functions
1	VB1	U-phase high-side floating supply voltage input
2	VB2	V-phase high-side floating supply voltage input
3	VD	Anode of bootstrap diodes
4	VB3	W-phase high-side floating supply voltage input
5	VCC1	High side logic supply voltage input
6	COM1	High side logic ground
7	HIN3	Logic input for W-phase high-side gate driver
8	HIN2	Logic input for V-phase high-side gate driver
9	HIN1	Logic input for U-phase high-side gate driver
10	VBB1	Positive DC bus supply voltage (be connected to VBB2 by PCB trace)
11	VBB2	Positive DC bus supply voltage (be connected to VBB2 by PCB trace)
12	W1	W-phase output (be connected to W2 by PCB trace)
13	V	V-phase output
14	W2	W-phase output (be connected to W1 by PCB trace)
15	LS2	U and V-phase power MOSFET Source (be connected to LS1 by PCB trace)
16	VREG	Regulator output
17	LS1	W-phase power MOSFET Source (be connected to LS2 by PCB trace)
18	LIN3	Logic input for W-phase low-side gate driver
19	LIN2	Logic input for V-phase low-side gate driver
20	LIN1	Logic input for U-phase low-side gate driver
21	COM2	Low side logic ground
22	FO	Fault signal output for thermal detection and UVLO, active high
23	VCC2	Low side logic supply voltage input
24	U	U-phase output

7. Typical Application

Capacitors should be placed near the IC. If the circuit noise is large, connect the noise reduction ceramic capacitor to the electrolytic capacitor in parallel.

Pull down resistance (about 100 kΩ) is built-in the HINx pin and the LINx pin. If the unstable signal or noisy signal may be input, connect the resistor in external to the HINx pin and the LINx pin.

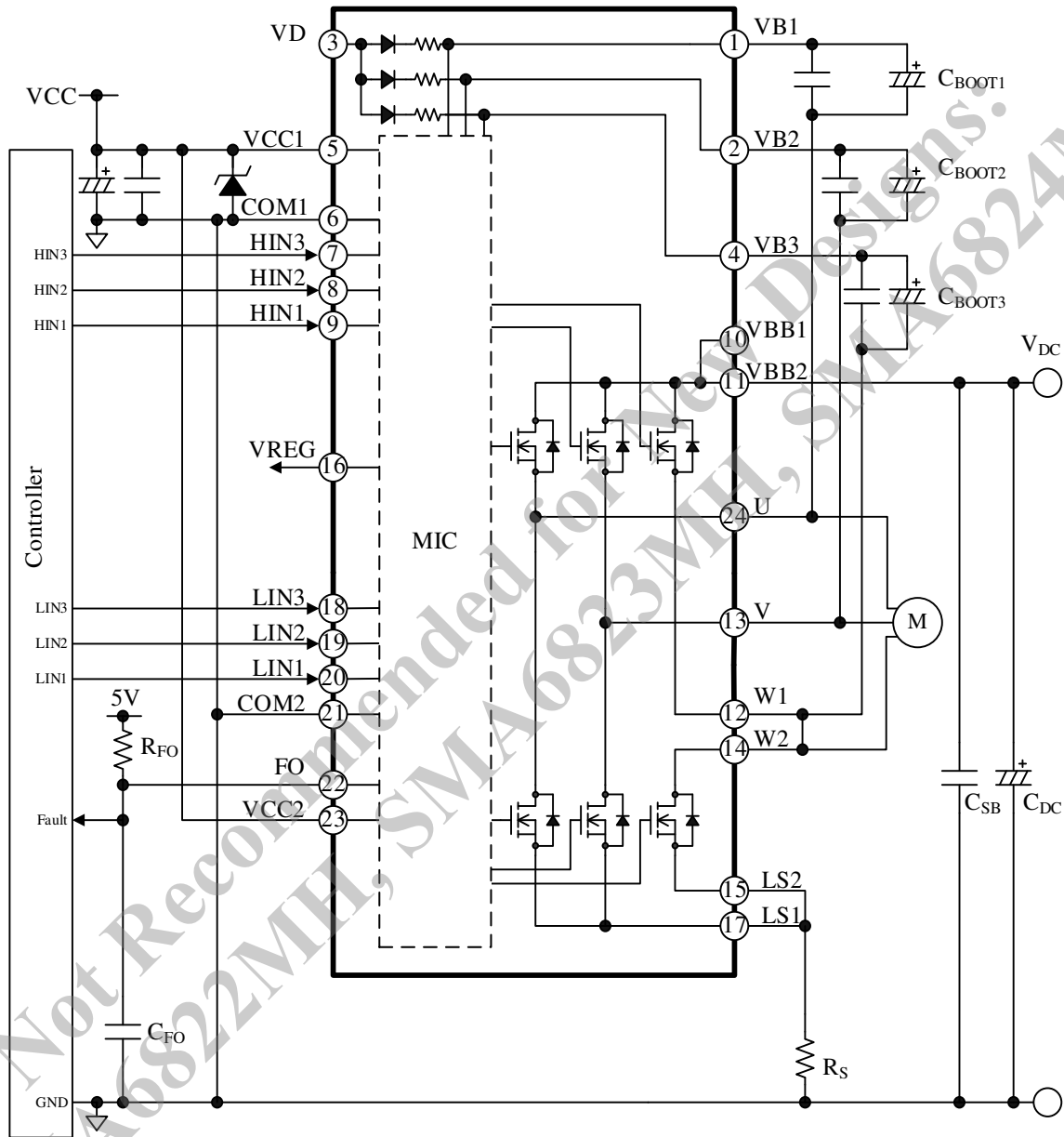

Figure 7-1. Typical Application

8. Timing Chart in Protection Operation

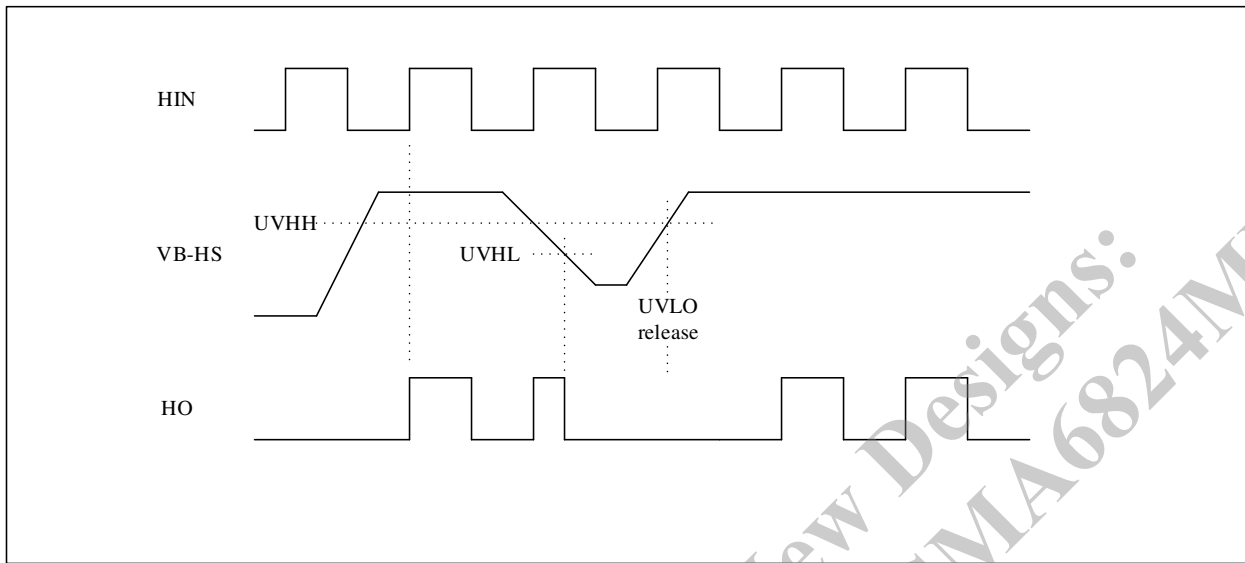

Figure 8-1. High-side Undervoltage Lockout for Power Supply (UVLO_VB)

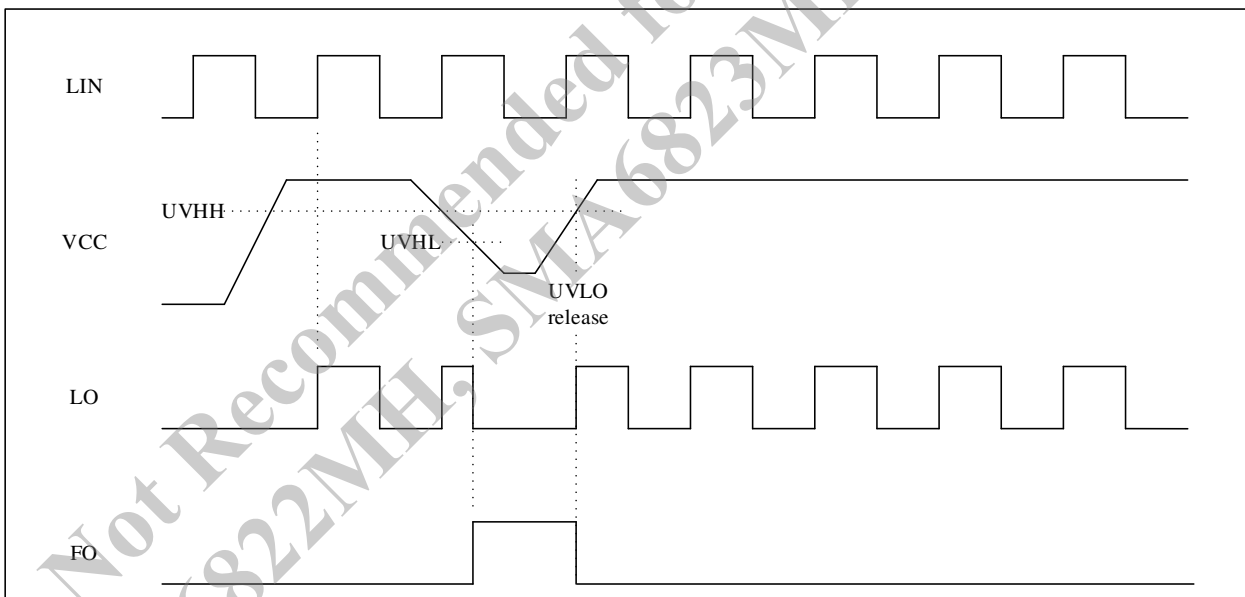

Figure 8-2. Low-side Undervoltage Lockout for Power Supply (UVLO_VCC)

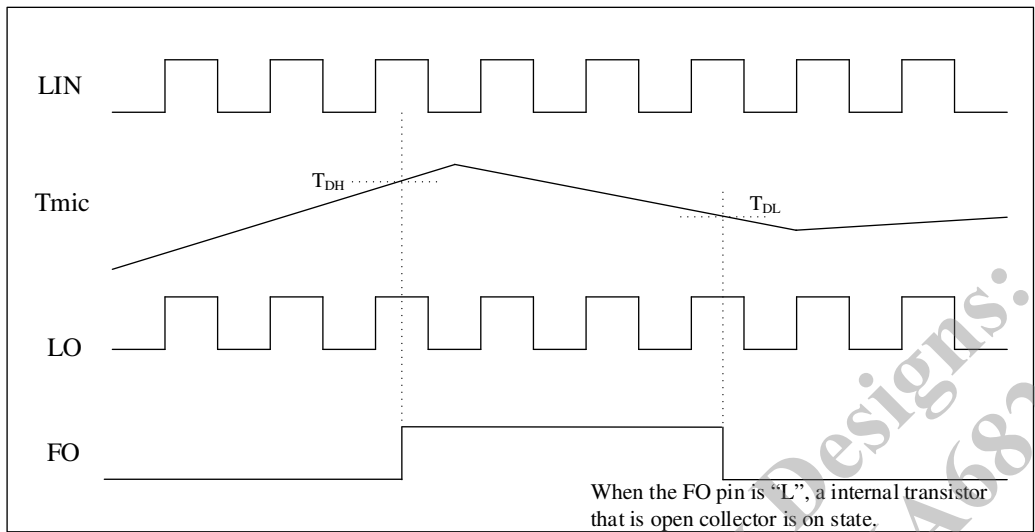

Figure 8-3. Thermal Detection (TD)

Not Recommended for New Designs:
SMA6822MH, SMA6823MH, SMA6824MH

10. Marking Diagrams

10.1. ZIP24 (Full Molded Type)

The marking diagrams of ZIP24 package is either in follows:

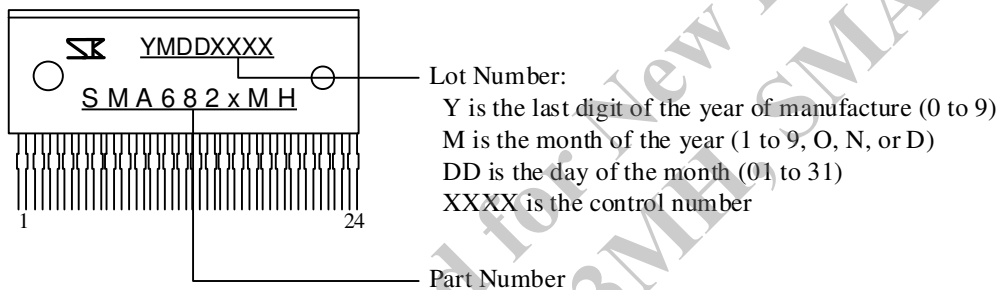
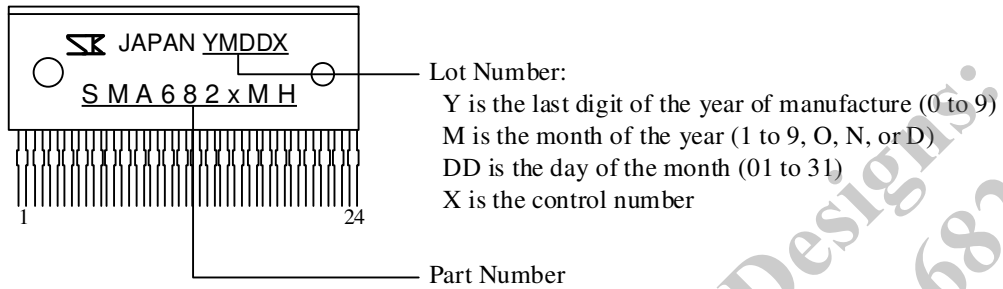

10.2. ZIP24 (Heatsink Type)

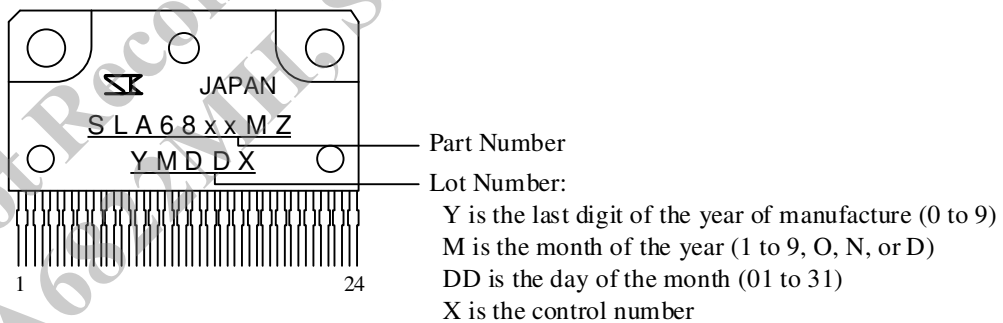

Important Notes

- All data, illustrations, graphs, tables and any other information included in this document as to Sanken's products listed herein (the "Sanken Products") are current as of the date this document is issued. All contents in this document are subject to any change without notice due to improvement of the Sanken Products, etc. Please make sure to confirm with a Sanken sales representative that the contents set forth in this document reflect the latest revisions before use.
- The Sanken Products are intended for use as components of general purpose electronic equipment or apparatus (such as home appliances, office equipment, telecommunication equipment, measuring equipment, etc.). Prior to use of the Sanken Products, please put your signature, or affix your name and seal, on the specification documents of the Sanken Products and return them to Sanken. When considering use of the Sanken Products for any applications that require higher reliability (such as transportation equipment and its control systems, traffic signal control systems or equipment, disaster/crime alarm systems, various safety devices, etc.), you must contact a Sanken sales representative to discuss the suitability of such use and put your signature, or affix your name and seal, on the specification documents of the Sanken Products and return them to Sanken, prior to the use of the Sanken Products. The Sanken Products are not intended for use in any applications that require extremely high reliability such as: aerospace equipment; nuclear power control systems; and medical equipment or systems, whose failure or malfunction may result in death or serious injury to people, i.e., medical devices in Class III or a higher class as defined by relevant laws of Japan (collectively, the "Specific Applications"). Sanken assumes no liability or responsibility whatsoever for any and all damages and losses that may be suffered by you, users or any third party, resulting from the use of the Sanken Products in the Specific Applications or in manner not in compliance with the instructions set forth herein.
- In the event of using the Sanken Products by either (i) combining other products or materials therewith or (ii) physically, chemically or otherwise processing or treating the same, you must duly consider all possible risks that may result from all such uses in advance and proceed therewith at your own responsibility.
- Although Sanken is making efforts to enhance the quality and reliability of its products, it is impossible to completely avoid the occurrence of any failure or defect in semiconductor products at a certain rate. You must take, at your own responsibility, preventative measures including using a sufficient safety design and confirming safety of any equipment or systems in/for which the Sanken Products are used, upon due consideration of a failure occurrence rate or derating, etc., in order not to cause any human injury or death, fire accident or social harm which may result from any failure or malfunction of the Sanken Products. Please refer to the relevant specification documents and Sanken's official website in relation to derating.
- No anti-radioactive ray design has been adopted for the Sanken Products.
- No contents in this document can be transcribed or copied without Sanken's prior written consent.
- The circuit constant, operation examples, circuit examples, pattern layout examples, design examples, recommended examples, all information and evaluation results based thereon, etc., described in this document are presented for the sole purpose of reference of use of the Sanken Products and Sanken assumes no responsibility whatsoever for any and all damages and losses that may be suffered by you, users or any third party, or any possible infringement of any and all property rights including intellectual property rights and any other rights of you, users or any third party, resulting from the foregoing.
- All technical information described in this document (the "Technical Information") is presented for the sole purpose of reference of use of the Sanken Products and no license, express, implied or otherwise, is granted hereby under any intellectual property rights or any other rights of Sanken.
- Unless otherwise agreed in writing between Sanken and you, Sanken makes no warranty of any kind, whether express or implied, including, without limitation, any warranty (i) as to the quality or performance of the Sanken Products (such as implied warranty of merchantability, or implied warranty of fitness for a particular purpose or special environment), (ii) that any Sanken Product is delivered free of claims of third parties by way of infringement or the like, (iii) that may arise from course of performance, course of dealing or usage of trade, and (iv) as to any information contained in this document (including its accuracy, usefulness, or reliability).
- In the event of using the Sanken Products, you must use the same after carefully examining all applicable environmental laws and regulations that regulate the inclusion or use of any particular controlled substances, including, but not limited to, the EU RoHS Directive, so as to be in strict compliance with such applicable laws and regulations.
- You must not use the Sanken Products or the Technical Information for the purpose of any military applications or use, including but not limited to the development of weapons of mass destruction. In the event of exporting the Sanken Products or the Technical Information, or providing them for non-residents, you must comply with all applicable export control laws and regulations in each country including the U.S. Export Administration Regulations (EAR) and the Foreign Exchange and Foreign Trade Act of Japan, and follow the procedures required by such applicable laws and regulations.
- Sanken assumes no responsibility for any troubles, which may occur during the transportation of the Sanken Products including the falling thereof, out of Sanken's distribution network.
- Although Sanken has prepared this document with its due care to pursue the accuracy thereof, Sanken does not warrant that it is error free and Sanken assumes no liability whatsoever for any and all damages and losses which may be suffered by you resulting from any possible errors or omissions in connection with the contents included herein.
- Please refer to the relevant specification documents in relation to particular precautions when using the Sanken Products, and refer to our official website in relation to general instructions and directions for using the Sanken Products.
- All rights and title in and to any specific trademark or tradename belong to Sanken or such original right holder(s).

DSGN-CEZ-16002