

DATE	REV	ECN	APP'D. BY
3-24-03	A4	5942	RGC

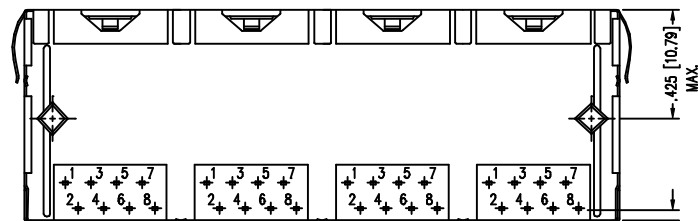

(.087 [2.46]) TYP.

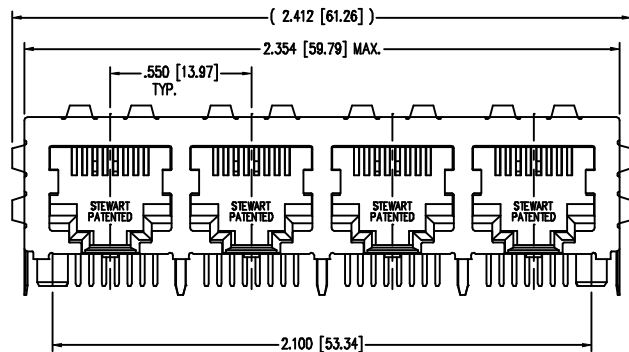
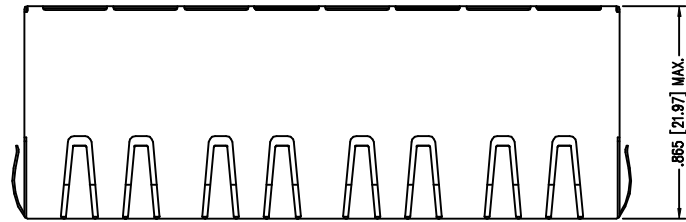
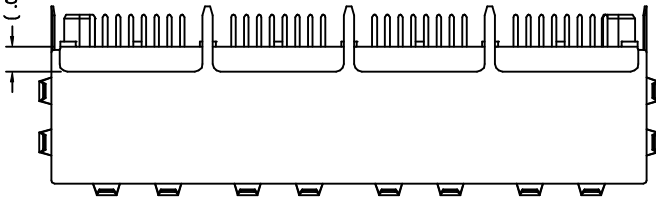

(.041 [1.03]) TYP.

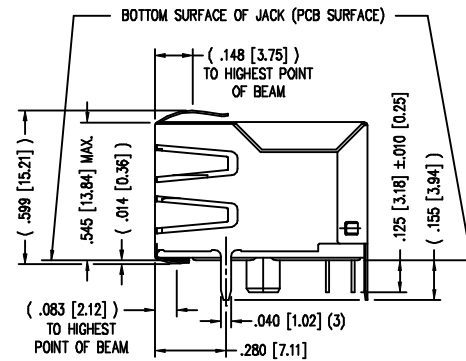

NOTES:

- CONNECTOR MATERIALS:
HOUSING: THERMOPLASTIC UL94 V-0
CONTACTS/SHIELD: COPPER ALLOY
SHIELD PLATING: NICKEL OR TIN
CONTACT PLATING: SELECTIVE GOLD IN CONTACT AREA
SEE CHART FOR PART NUMBER
- PRODUCT DESIGNED FOR CATEGORY 5 APPLICATIONS.
- TOLERANCES COMPLY WITH F.C.C. DIMENSION REQUIREMENTS.
- THE SUGGESTED PANEL OPENING IS INTENDED TO GIVE USER THE ABILITY TO HAVE REASONABLE JACK/PANEL CLEARANCES, YET MAINTAIN GROUNDING CAPABILITY. THESE VARIABLES CAN BE ADJUSTED IN EITHER DIRECTION BUT MAY CARRY SOME CONSEQUENCES IN THE FORM OF LOWER MATING FORCES OR TIGHTER ASSEMBLY TOLERANCES.

50 MICRO-INCHES [1.27um]	SS-718804S-A-PG4-AC-50
30 MICRO-INCHES [0.76um]	SS-718804S-A-PG4-AC
CONTACT PLATING IN MATING AREA	PART NUMBER

THIRD ANGLE PROJECTION

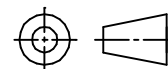

DO NOT SCALE DRAWING
DRAWING IS SUBJECT TO
CHANGE WITHOUT NOTICE

DIMENSIONS: INCHES [METRIC]
UNLESS OTHERWISE SPECIFIED
TOLERANCES ARE ±.005 [0.13]
ANGLES ARE ± 1°

SHEET NO. 1 OF 2

Stewart Connector

<http://www.stewartconnector.com>

11118 Susquehanna Trail South
Glen Rock, PA 17327-9199
(717) 235-7512 Fax: (717) 235-7954

TITLE: 4 PORT HARMONICA JACK PAC, EMI-RFI ENHANCED SHIELD
ESD GROUNDED

DRN BY: DAB	DATE 3-24-03
CKD BY: TRM	DATE 3-24-03
APPD BY: RGC	DATE 3-24-03
DWG NO. CT710031	REV. A4

THIS DRAWING AND THE SUBJECT MATTER SHOWN THEREON ARE CONFIDENTIAL AND THE PROPRIETARY PROPERTY OF STEWART CONNECTOR ("SCS") AND SHALL NOT BE REPRODUCED, COPIED OR USED IN ANY MANNER WITHOUT PRIOR WRITTEN CONSENT OF "SCS". THE SUBJECT MATTER MAY BE PATENTED OR A PATENT MAY BE PENDING. © SCS

DATE	REV	ECN	APP'D. BY
3-24-03	A4	5942	RGC

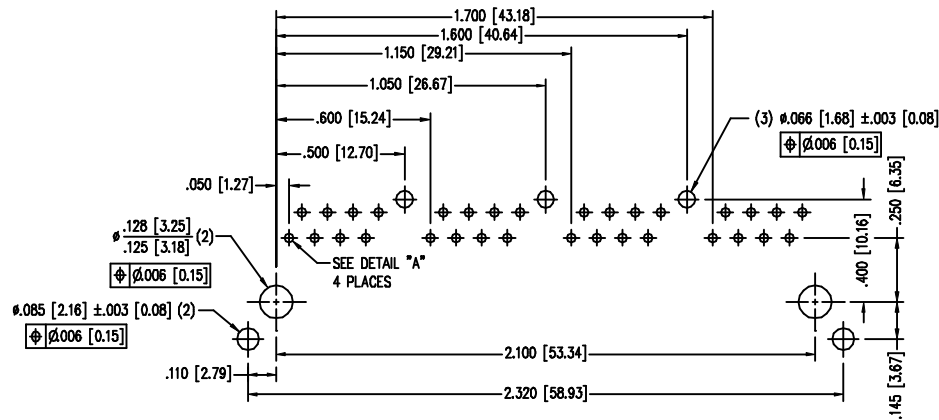

P.C.B. RECOMMENDED HOLE LAYOUT
SEEN FROM COMPONENT SIDE
ALL CENTERLINE DIMENSIONS ARE BASIC.

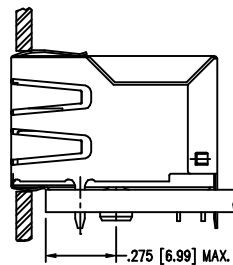
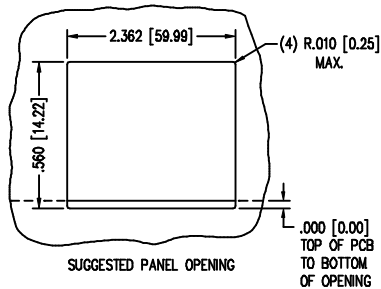
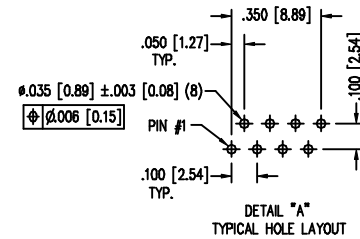

THIRD ANGLE PROJECTION		<h1>Stewart Connector</h1> <p>11118 Susquehanna Trail South Glen Rock, PA 17327-9199 (717) 235-7512 Fax: (717) 235-7954</p> <p>http://www.stewartconnector.com</p>	
DO NOT SCALE DRAWING DRAWING IS SUBJECT TO CHANGE WITHOUT NOTICE		TITLE: 4 PORT HARMONICA JACK PAC, EMI-RFI ENHANCED SHIELD ESD GROUNDED	
DIMENSIONS: INCHES [METRIC] UNLESS OTHERWISE SPECIFIED TOLERANCES ARE ±.005 [0.13] ANGLES ARE ± 1°		DRN BY: DAB DATE 3-24-03 CKD BY: TRM DATE 3-24-03 APPD BY: RGC DATE 3-24-03	
SHEET NO. 2 OF 2		DWG NO. CT710031 REV. A4	

THIS DRAWING AND THE SUBJECT MATTER SHOWN THEREON ARE CONFIDENTIAL AND THE PROPRIETARY PROPERTY OF STEWART CONNECTOR ("SCS") AND SHALL NOT BE REPRODUCED, COPIED OR USED IN ANY MANNER WITHOUT PRIOR WRITTEN CONSENT OF "SCS". THE SUBJECT MATTER MAY BE PATENTED OR A PATENT MAY BE PENDING. © SCS