

APPLICATIONS

4" Recessed downlight retrofit solution with integrated LED power supply and thermal management system combined in a single compact unit designed to fit most standard 4" recessed cans.

ILLUMINATION

- Long Life LEDs with up to 50,000 hours at 70% lumen maintenance.
- Choice of 2700K, 3000K, 4000K or 5000K color temperature with 80 CRI.
- Produces 550 - 730 lumens output from luminaire.

ELECTRICAL

- Built-in LED driver.
- Includes Socket Adapter.
- Save 75% compared to incandescent sources.
- Down to 10% dimmable with most dimmers.
- Voltage: 120V, 50-60Hz.
- Operation temperature of -20°C - 40°C (-4°F - 104°F).
- Power Consumption: 8 Watts.

HOUSING

- Compatible with most 4" recessed cans.
- Durable thermoplastic construction.
- E26 medium screw-base Edison connector provides easy retrofit of incandescent housings.
- Compatible with insulated, non-insulated and air-tight ceilings.
- 4" square baffle snap-in (option) - use "SQT" in lieu of "RND" in part number.



MOUNTING

- Easy installation with integral clips.
- No tools required for installation.

WARRANTY/LISTING

- Tested in accordance with IESNA LM79 & LM80.
- ETL Listed for wet location.
- Energy Star qualified.
- Passes FCC Class B.
- Meets State of California Title 24 requirements.
- Five year warranty on all electronics and housing.

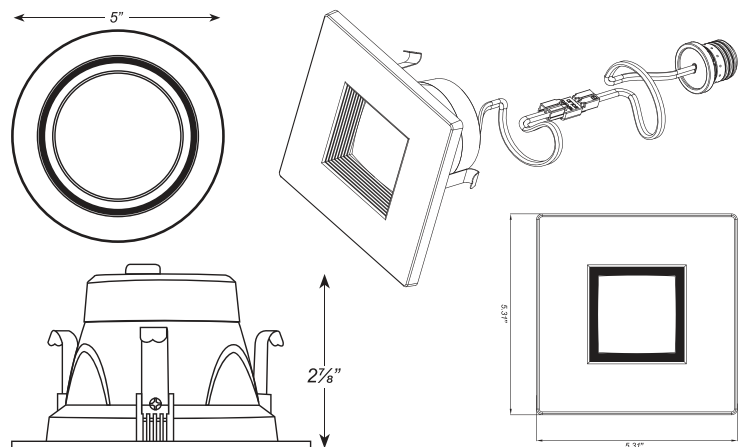

MODEL	WATT	LUMENS	COLOR TEMP	CRI
CLRDL4-827-RND	8	550	2700K	80
CLRDL4-830-RND	8	630	3000K	80
CLRDL4-840-RND	8	665	4000K	80
CLRDL4-850-RND	8	730	5000K	80

COMPATIBLE DIMMERS	MODEL NUMBERS
Lutron Maestro C-L	MACL-153MR
Lutron Skylark C-L	SCL-153P
Leviton Sureslide	6674
Lutron	PD-6WCL
Legrand Harmony	HCL453PTCCCV6