

## 200mA, 250V SMD Switching Diode

### FEATURES

- Low power loss, high efficiency
- Ideal for automated placement
- High surge current capability
- Moisture sensitivity level: level 1, per J-STD-020
- RoHS Compliant
- Halogen-free according to IEC 61249-2-21

### APPLICATIONS

- Switching mode power supply (SMPS)

### MECHANICAL DATA

- Case: SOT-23
- Molding compound meets UL 94 V-0 flammability rating
- Terminal: Matte tin plated leads, solderable per J-STD-002
- Meet JESD 201 class 1A whisker test
- Weight:  $8 \pm 0.5$  mg (approximately)

KEY PARAMETERS		
PARAMETER	VALUE	UNIT
$I_F$	200	mA
$V_{RRM}$	250	V
$I_{FSM}$	1	A
$V_F$ at $I_F=200mA$	1.25	V
$T_{J\ MAX}$	150	°C
Package	SOT-23	



ABSOLUTE MAXIMUM RATINGS ( $T_A = 25^\circ\text{C}$ unless otherwise noted)						
PARAMETER	SYMBOL	BAS21	BAS21A	BAS21C	BSA21S	UNIT
Marking code on the device		JS	JS2	JS3	JS4	
Power dissipation	$P_D$	225				mW
Repetitive peak reverse voltage	$V_{RRM}$	250				V
Repetitive peak forward current	$I_{FRM}$	625				mA
Forward current	$I_F$	200				mA
Non-Repetitive peak forward surge current @ $t = 8.3ms$	$I_{FSM}$	1				A
Junction temperature range	$T_J$	-55 to +150				°C
Storage temperature range	$T_{STG}$	-55 to +150				°C

<b>THERMAL PERFORMANCE</b>			
<b>PARAMETER</b>	<b>SYMBOL</b>	<b>TYP</b>	<b>UNIT</b>
Junction-to-ambient thermal resistance	$R_{\theta JA}$	500	°C/W

<b>ELECTRICAL SPECIFICATIONS</b> ( $T_A = 25^\circ\text{C}$ unless otherwise noted)					
<b>PARAMETER</b>	<b>CONDITIONS</b>	<b>SYMBOL</b>	<b>MIN</b>	<b>MAX</b>	<b>UNIT</b>
Forward voltage per diode <sup>(1)</sup>	$I_F = 100\text{mA}, T_J = 25^\circ\text{C}$	$V_F$	-	1.00	V
	$I_F = 200\text{mA}, T_J = 25^\circ\text{C}$			1.25	
Reverse voltage	$I_R = 100 \mu\text{A}, T_J = 25^\circ\text{C}$	$V_R$	250	-	V
Reverse current @ rated $V_R$ per diode <sup>(2)</sup>	$V_R = 200 \text{V}, T_J = 25^\circ\text{C}$	$I_R$	-	0.1	$\mu\text{A}$
Junction capacitance	$f=1 \text{MHz}, V_R=1\text{V}$	$C_J$	-	5	pF
Reverse recovery time	$I_F=I_R= 30\text{mA}, R_L= 100\Omega,$ $I_{RR}= 1\text{mA}$	$t_{rr}$	-	50	ns

**Notes:**

1. Pulse test with PW=0.3 ms
2. Pulse test with PW=30 ms

<b>ORDERING INFORMATION</b>		
<b>ORDERING CODE</b>	<b>PACKAGE</b>	<b>PACKING</b>
BAS2xx RF	SOT-23	3K / 7" Reel
BAS2xx RFG	SOT-23	3K / 7" Reel
BAS2xx R5	SOT-23	10K / 13" Reel
BAS2xx R5G	SOT-23	10K / 13" Reel
BAS2xx-B0 RF	SOT-23	3K / 7" Reel
BAS2xx-B0 RFG	SOT-23	3K / 7" Reel
BAS2xx-B0 R5	SOT-23	10K / 13" Reel
BAS2xx-B0 R5G	SOT-23	10K / 13" Reel
BAS2xx-D0 RF	SOT-23	3K / 7" Reel
BAS2xx-D0 RFG	SOT-23	3K / 7" Reel
BAS2xx-D0 R5	SOT-23	10K / 13" Reel
BAS2xx-D0 R5G	SOT-23	10K / 13" Reel

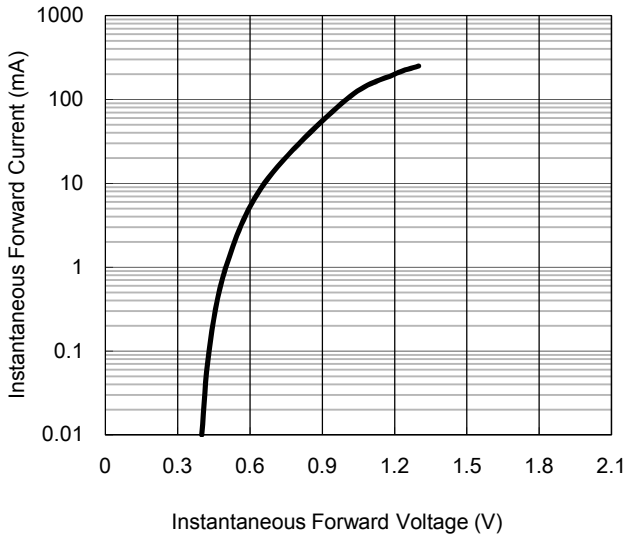
**Notes:**

1. "xx" is device code from "1" to "1S"
2. "G" means green compound (halogen free)

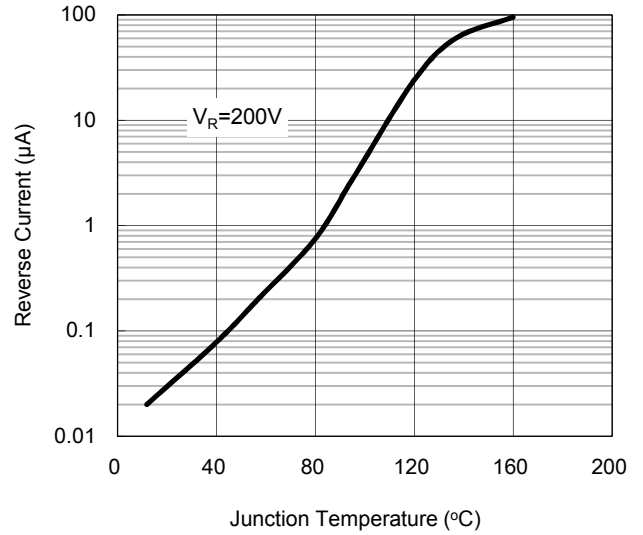
**CHARACTERISTICS CURVES**

( $T_A = 25^\circ\text{C}$  unless otherwise noted)

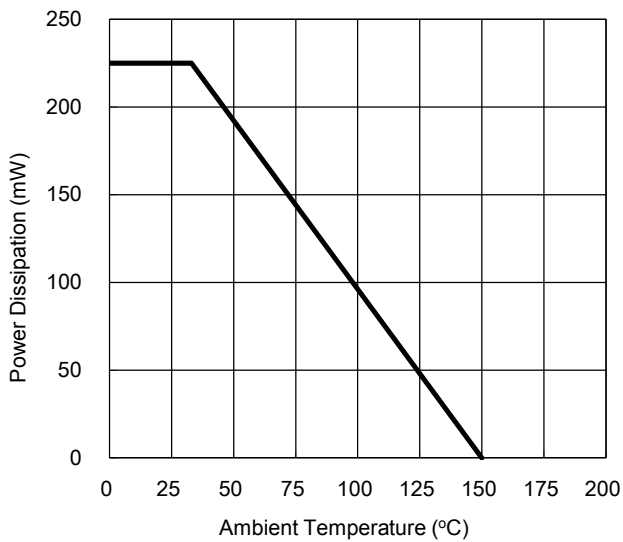
**Fig.1 Typical Forward Characteristics**



**Fig. 2 Reverse Current VS. Junction Temperature**

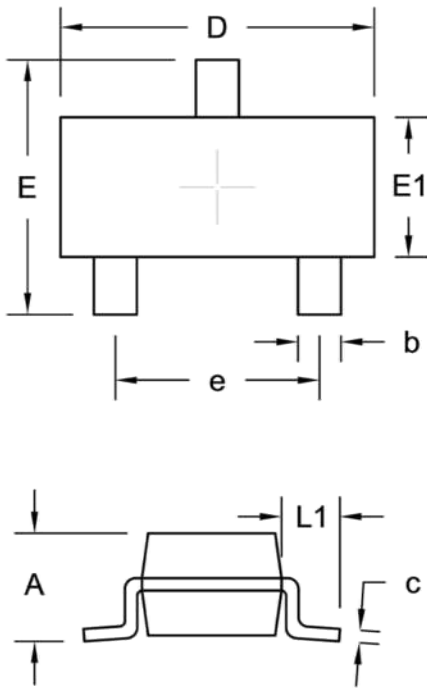


**Fig.3 Admissible Power Dissipation Curve**



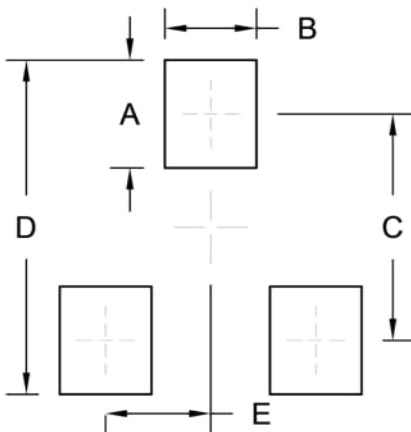
**PACKAGE OUTLINE DIMENSION**

SOT-23



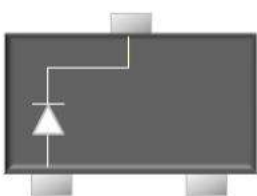
DIM.	Unit (mm)		Unit (inch)	
	Min.	Max.	Min.	Max.
A	0.89	1.12	0.035	0.044
b	0.30	0.50	0.012	0.020
c	0.08	0.20	0.003	0.008
D	2.80	3.04	0.110	0.120
E	2.10	2.64	0.083	0.104
E1	1.20	1.40	0.047	0.055
e	1.90 BSC		0.075 BSC	
L1	0.54 REF.		0.021 REF.	

**SUGGESTED PAD LAYOUT**

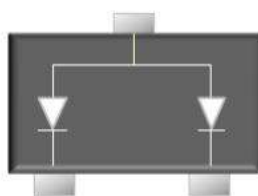


Symbol	Unit (mm)	Unit (inch)
A	1.00	0.039
B	0.85	0.033
C	2.10	0.083
D	3.10	0.122
E	0.98	0.039

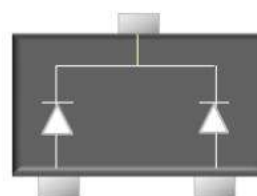
**PIN CONFIGURATION**



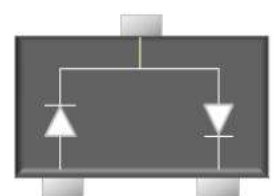
BAS21



BAS21A



BAS21C



BAS21S

## Notice

Specifications of the products displayed herein are subject to change without notice. TSC or anyone on its behalf, assumes no responsibility or liability for any errors or inaccuracies.

Purchasers are solely responsible for the choice, selection, and use of TSC products and TSC assumes no liability for application assistance or the design of Purchasers' products.

Information contained herein is intended to provide a product description only. No license, express or implied, to any intellectual property rights is granted by this document. Except as provided in TSC's terms and conditions of sale for such products, TSC assumes no liability whatsoever, and disclaims any express or implied warranty, relating to sale and/or use of TSC products including liability or warranties relating to fitness for a particular purpose, merchantability, or infringement of any patent, copyright, or other intellectual property right.

The products shown herein are not designed for use in medical, life-saving, or life-sustaining applications. Customers using or selling these products for use in such applications do so at their own risk and agree to fully indemnify TSC for any damages resulting from such improper use or sale.