

NOTES:

1. FOR WAVESOLDERING (SOLDER BATH TEMPERATURE 240°C FOR 5 SEC. AND SOLDER PREHEAT 120°C FOR 120 SEC.)
2. METALSHELLS: COPPER ALLOY; min. 315µm TIN over 40-80µm NICKEL
3. INSULATORS: PBT GF UL 94 V-0; BLACK
4. CONTACTS: COPPER ALLOY
PLATING (SEE PART NO):
 PLEASE ADD A for GOLD FLASH over NICKEL (PREFERRED TYPE)
 PLEASE ADD B for 20µm HARD GOLD over min. 50µm NICKEL
 PLEASE ADD C for 30µm HARD GOLD over min. 50µm NICKEL
5. METAL BRACKETS: ZINC DIE CAST;
300µm COPPER/40-120µm NICKEL/120-200µm TIN
6. THREADED INSERTS:
COPPER ALLOY; min. 200µm TIN over 80µm NICKEL
7. FRAME: ZINC DIE CAST, NICKEL PLATED
8. RUBBER GASKET: TPE
9. O-RING: SILICON; BLUE
10. SEALING COMPOUND: PUR; BLUE
11. HEXLOCKING SCREWS: STAINLESS STEEL
12. PCB HOLE DRILLINGS AND PANEL CUT-OUT ON SHEET 2
13. RECOMMENDED TORQUE FOR MOUNTING SCREW
35Ncm (3.1 in.LB/max.40Ncm (3.5 in.LB))
14. CONNECTOR IS PART MARKED: 6STD15P□U99R10X CONEC ABC (see note 4)

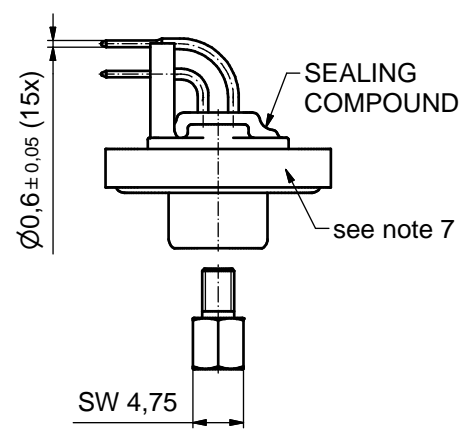
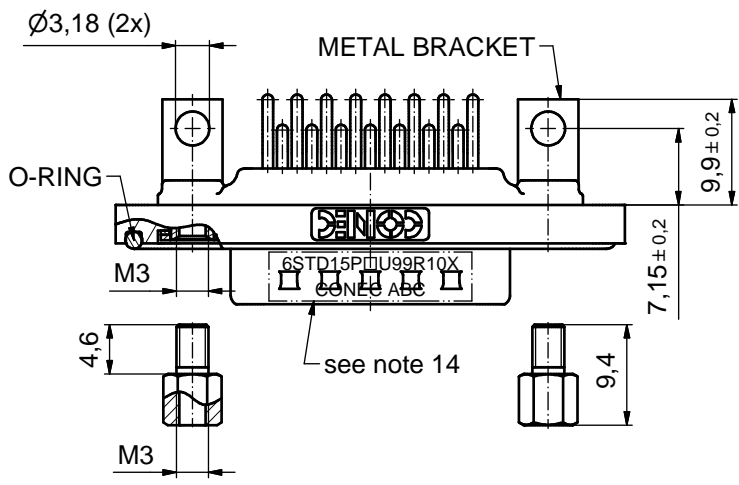
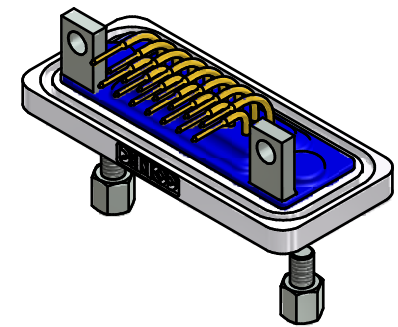
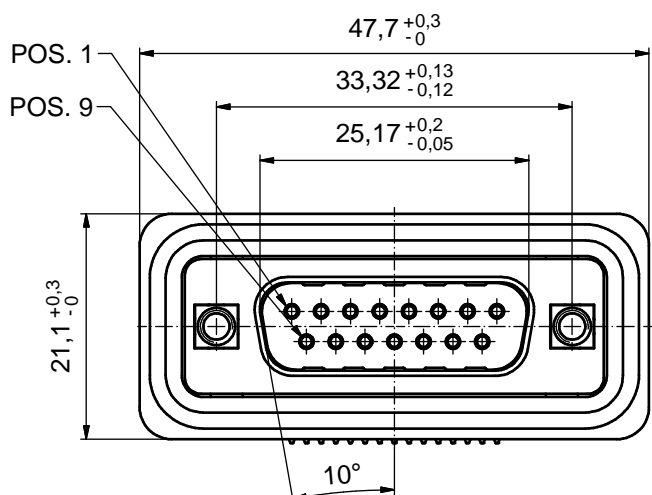
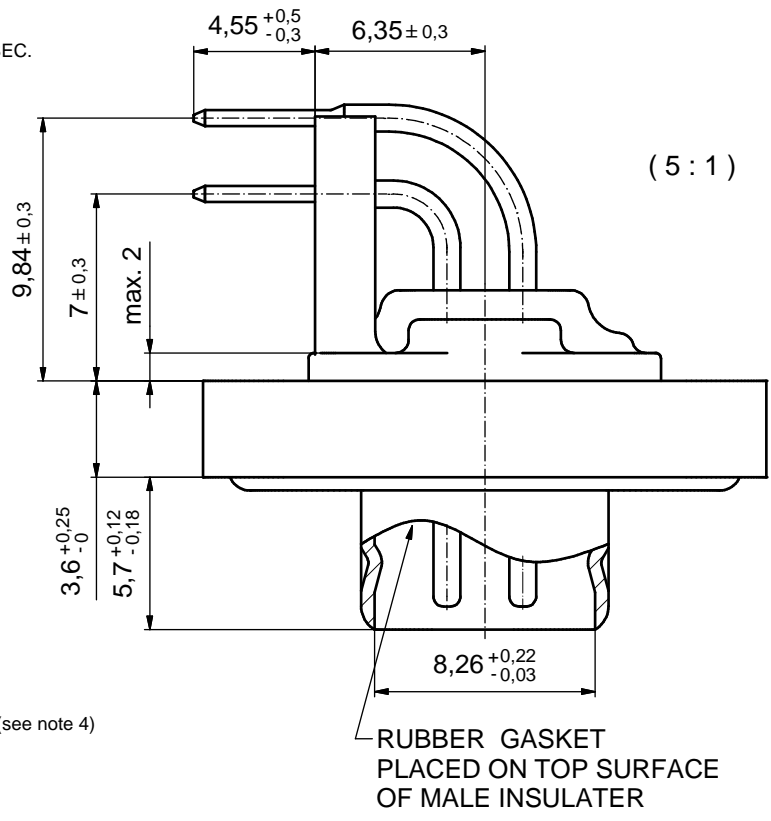

AT ALL TIMES WATER RESISTANT CONNECTORS NOT IN USE SHOULD BE COVERED WITH A CONEC WATER RESISTANT CAP OR WATER TIGHT HOOD.

Directive 2002/95/EC RoHS compliant

THIS DRAWING MAY NOT BE COPIED OR REPRODUCED IN ANY WAY, AND MAY NOT BE PASSED ON TO A THIRD PARTY WITHOUT WRITTEN PERMISSION. OWNERSHIP AND COPYRIGHT OF CONEC GmbH				tolerance		dim. in mm	scale:	2:1 (5:1)
DO NOT ALTER CAD DRAWING BY HAND				drawn	21.09.12	Schmidt	title: D-SUB MALE 90° 15pos. SOLDER PIN ANGLED with threaded insert, metal bracket, hex bolt dwg no: DIN-A3 15K1A1163 part no: 6STD15P□U99R10X (see note 4)	
				appd.	21.09.12	Fischer		
				norm				
				d-old				
a	Original							sh: 1
rev.	description	date	name					

