



# Aluminum electrolytic capacitors

## Snap-in capacitors

**Series/Type:** B43540  
**Date:** December 2013

## Long-life grade capacitors

### Applications

- Frequency converters
- Solar inverters
- Uninterruptible power supplies
- Professional power supplies
- Medical appliances
- Telecommunications

### Features

- Voltage derating ( $0.93 \cdot V_R$ ) enables 105 °C operation, more details available upon request
- Base cooling available upon request for case sizes 30 × 35 mm to 35 × 55 mm
- Long useful life
- High reliability
- Outstanding ripple current capability
- Extremely improved performance at high frequencies
- Outstanding low ESR at operating conditions above 50 °C
- High CV product, compact
- Optimized internal thermal resistance
- Different case sizes available for each capacitance value
- Capacitors with all insulation versions pass the needle flame test according to IEC 60695-11-5 for all flame exposure times up to 120 s
- RoHS-compatible

### Construction

- Charge/discharge-proof, polar
- Aluminum case, fully insulated with PVC
- Version with PET insulation available
- Version with additional PET insulation cap on terminal side available for insulating the capacitor from the PCB
- Snap-in solder pins to hold component in place on PC-board
- Minus pole marking on case surface
- Minus pole not insulated from case
- Overload protection by safety vent on the case wall

### Terminals

- Standard version with 2 terminals, 2 lengths available: 6.3 and 4.5 mm
- 3 terminals to ensure correct insertion: length 4.5 mm

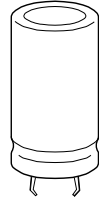

**Specifications and characteristics in brief**

Rated voltage $V_R$	200 ... 450 V DC										
Surge voltage $V_S$	$1.15 \cdot V_R$ (for $V_R \leq 250$ V DC) $1.10 \cdot V_R$ (for $V_R \geq 400$ V DC)										
Rated capacitance $C_R$	68 ... 2200 $\mu\text{F}$										
Capacitance tolerance	$\pm 20\% \triangleq \text{M}$										
Dissipation factor $\tan \delta$ (20 °C, 120 Hz)	$V_R \leq 400$ V DC: $\tan \delta \leq 0.15$ $V_R = 450$ V DC: $\tan \delta \leq 0.20$										
Leakage current $I_{\text{leak}}$ (5 min, 20 °C)	$I_{\text{leak}} \leq 0.3 \mu\text{A} \cdot \left( \frac{C_R}{\mu\text{F}} \cdot \frac{V_R}{\text{V}} \right)^{0.7} + 4 \mu\text{A}$										
Self-inductance ESL	Approx. 20 nH										
Useful life <sup>1)</sup>		Requirements:									
85 °C; $V_R$ ; $I_{\text{AC,R}}$	> 10000 h	$\Delta\text{C}/\text{C} \leq \pm 20\%$ of initial value									
40 °C; $V_R$ ; $1.15 \cdot I_{\text{AC,R}}$	> 250000 h	$\tan \delta \leq 2$ times initial specified limit									
		$I_{\text{leak}} \leq$ initial specified limit									
Voltage endurance test 85 °C; $V_R$	5000 h	Post test requirements:									
		$\Delta\text{C}/\text{C} \leq \pm 10\%$ of initial value									
		$\tan \delta \leq 1.3$ times initial specified limit									
		$I_{\text{leak}} \leq$ initial specified limit									
Vibration resistance test	To IEC 60068-2-6, test Fc: Frequency range 10 Hz ... 55 Hz, displacement amplitude 0.35 mm, acceleration max. 5 g, duration $3 \times 2$ h. Capacitor mounted by its body which is rigidly clamped to the work surface.										
Characteristics at low temperature	Max. impedance ratio at 100 Hz	<table border="1"> <tr> <td><math>V_R</math></td> <td><math>\leq 400</math> V</td> <td>450 V</td> </tr> <tr> <td><math>Z_{-25\text{ °C}} / Z_{20\text{ °C}}</math></td> <td>3</td> <td>7</td> </tr> <tr> <td><math>Z_{-40\text{ °C}} / Z_{20\text{ °C}}</math></td> <td>7</td> <td>12</td> </tr> </table>	$V_R$	$\leq 400$ V	450 V	$Z_{-25\text{ °C}} / Z_{20\text{ °C}}$	3	7	$Z_{-40\text{ °C}} / Z_{20\text{ °C}}$	7	12
$V_R$	$\leq 400$ V	450 V									
$Z_{-25\text{ °C}} / Z_{20\text{ °C}}$	3	7									
$Z_{-40\text{ °C}} / Z_{20\text{ °C}}$	7	12									
IEC climatic category	To IEC 60068-1: $V_R \leq 400$ V DC: 40/085/56 (–40 °C/+85 °C/56 days damp heat test) $V_R = 450$ V DC: 25/085/56 (–25 °C/+85 °C/56 days damp heat test) The capacitors can be operated in the temperature range of –40 °C to +85 °C but the impedance at –40 °C should be taken into consideration.										
Detail specification	Similar to CECC 30301-811										
Sectional specification	IEC 60384-4										

1) Refer to chapter "General technical information, 5 Useful life" on how to interpret useful life.



B43540

Outstanding ripple current – 85 °C

## Dimensional drawings

### Snap-in capacitors with standard insulation (PVC or PET)

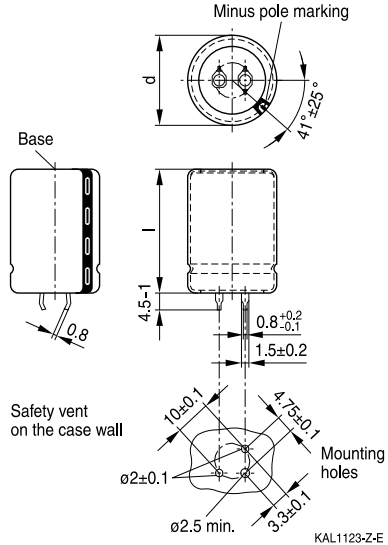
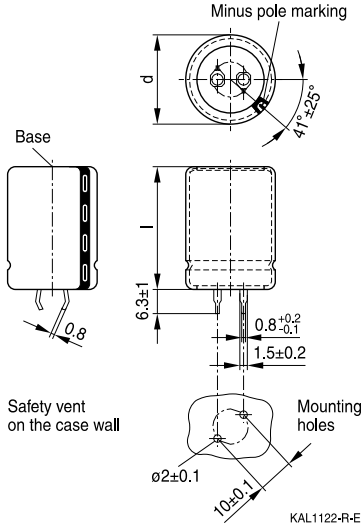

Snap-in terminals, length (6.3 ± 1) mm.  
Also available in a shorter version with a length of (4.5 – 1) mm. PET insulation is marked with label "PET" on the sleeve.

Snap-in capacitors are also available with 3 terminals (length (4.5 – 1) mm). PET insulation is marked with label "PET" on the sleeve.

Dimensions (mm)		Approx. weight (g)	Packing units (pcs.)
d +1	l ±2		
25	25	13	130
25	30	17	130
25	35	19	130
25	40	22	130
25	45	25	130
25	50	29	130
25	55	32	130

Dimensions (mm)		Approx. weight (g)	Packing units (pcs.)
d +1	l ±2		
30	25	17	80
30	30	23	80
30	35	29	80
30	40	36	80
30	45	41	80
30	50	46	80
30	55	53	80
35	25	22	60
35	30	29	60
35	35	36	60
35	40	41	60
35	45	56	60
35	50	70	60
35	55	81	60

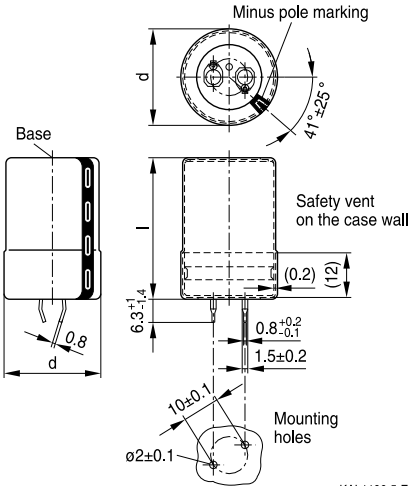
**Snap-in capacitors with PVC insulation and PET insulation cap on terminal side**

KAL1196-5-E

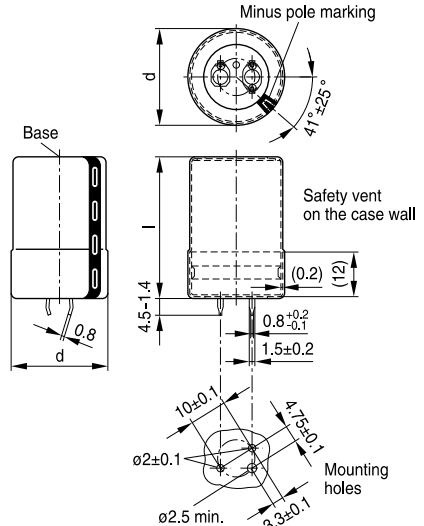

KAL1197-D-E

Snap-in terminals, length  $(6.3 + 1/-1.4)$  mm. Also available in a shorter version with a length of  $(4.5 - 1.4)$  mm. PET insulation cap is positioned under the insulation sleeve.

Snap-in capacitors are also available with 3 terminals (length  $(4.5 - 1.4)$  mm). PET insulation cap is positioned under the insulation sleeve.

Dimensions (mm)		Approx. weight (g)	Packing units (pcs.)
d +1.4	l +2.2/-2		
25	25	13	115
25	30	17	115
25	35	19	115
25	40	22	115
25	45	25	115
25	50	29	115
25	55	32	115

Dimensions (mm)		Approx. weight (g)	Packing units (pcs.)
d +1.4	l +2.2/-2		
30	25	17	80
30	30	23	80
30	35	29	80
30	40	36	80
30	45	41	80
30	50	46	80
30	55	53	80
35	25	22	60
35	30	29	60
35	35	36	60
35	40	41	60
35	45	56	60
35	50	70	60
35	55	81	60

**B43540**
**Outstanding ripple current – 85 °C**
**Packing of snap-in capacitors**

For ecological reasons the packing is pure cardboard. Components can be withdrawn (in full or in part) in the correct position for insertion.

**Ordering codes for terminal styles and insulation features**

Identification in 3rd block of ordering code

Snap-in capacitors

Terminal version	Insulation version		
	PVC	PET	PVC plus PET cap
Standard terminals 6.3 mm	M000	M060	M080
Short terminals 4.5 mm	M007	M067	M087
3 terminals 4.5 mm	M002	M062	M082

Ordering examples:

- B43540A5107M007 } snap-in capacitor with short terminals and standard PVC insulation
- B43540A5107M062 } snap-in capacitor with 3 terminals and PET insulation
- B43540A5107M080 } snap-in capacitor with standard terminals and PVC insulation with additional PET insulation cap on terminal side

**Overview of available types**

$V_R$ (V DC)	200	250	400	450
	Case dimensions $d \times l$ (mm)			
$C_R$ ( $\mu\text{F}$ )				
68				25 × 25
82				25 × 30
100			25 × 25	25 × 30 30 × 25
120			25 × 30	25 × 35 30 × 30
150			25 × 35 30 × 25	25 × 35 30 × 30 35 × 25
180			25 × 40 30 × 30 35 × 25	25 × 45 30 × 35 35 × 30
220			25 × 40 30 × 30 35 × 30	25 × 50 30 × 40 35 × 30
270		25 × 25	25 × 45 30 × 35 35 × 30	25 × 55 30 × 40 35 × 35
330	25 × 25	25 × 30	25 × 55 30 × 45 35 × 35	30 × 50 35 × 40
390	25 × 30 30 × 25	25 × 35 30 × 25	30 × 45 35 × 35	30 × 55 35 × 45
470	25 × 30 30 × 25	25 × 35 30 × 30	30 × 50 35 × 45	35 × 50
560	25 × 35 30 × 30	25 × 40 30 × 30 35 × 25	35 × 50	35 × 55
680	25 × 40 30 × 30 35 × 25	25 × 45 30 × 35 35 × 30	35 × 55	
820	25 × 45 30 × 35 35 × 30	25 × 55 30 × 40 35 × 35		

**B43540**
**Outstanding ripple current – 85 °C**

$V_R$ (V DC)	200	250	400	450
	Case dimensions $d \times l$ (mm)			
$C_R$ ( $\mu$ F)				
1000	25 × 50 30 × 40 35 × 35	30 × 45 35 × 35		
1200	30 × 45 35 × 35	30 × 55 35 × 40		
1500	30 × 50 35 × 40	35 × 50		
1800	35 × 45	35 × 55		
2200	35 × 55			

The capacitance and voltage ratings listed above are available in different cases upon request. Other voltage and capacitance ratings are also available upon request.

**Technical data and ordering codes**

$C_R$	Case dimensions	$ESR_{typ}$ 100 Hz	$ESR_{typ}$ 300 Hz	$Z_{max}$ 10 kHz	$I_{AC,max}$ 100 Hz	$I_{AC,R}^{1)}$ 100 Hz	Ordering code (composition see below)
100 Hz	d × l	20 °C	60 °C	20 °C	60 °C	85 °C	
μF	mm	mΩ	mΩ	mΩ	A	A	
<b><math>V_R = 200</math> V DC</b>							
330	25 × 25	270	110	340	3.11	1.59	B43540A2337M0*#
390	25 × 30	230	95	290	3.55	1.81	B43540A2397M0*#
390	30 × 25	220	80	270	3.69	1.88	B43540B2397M0*#
470	25 × 30	190	75	240	3.90	1.99	B43540A2477M0*#
470	30 × 25	180	70	230	4.05	2.06	B43540B2477M0*#
560	25 × 35	160	65	200	4.43	2.26	B43540A2567M0*#
560	30 × 30	150	55	190	4.62	2.36	B43540B2567M0*#
680	25 × 40	130	55	160	5.06	2.58	B43540A2687M0*#
680	30 × 30	120	45	160	5.10	2.60	B43540B2687M0*#
680	35 × 25	130	55	170	5.07	2.58	B43540C2687M0*#
820	25 × 45	110	45	140	5.73	2.92	B43540A2827M0*#
820	30 × 35	100	40	130	5.82	2.97	B43540B2827M0*#
820	35 × 30	110	45	140	6.32	3.22	B43540C2827M0*#
1000	25 × 50	90	36	110	6.51	3.32	B43540A2108M0*#
1000	30 × 40	85	32	110	7.24	3.69	B43540B2108M0*#
1000	35 × 35	90	38	110	7.26	3.70	B43540C2108M0*#
1200	30 × 45	70	26	90	8.18	4.17	B43540A2128M0*#
1200	35 × 35	75	32	100	7.95	4.05	B43540B2128M0*#
1500	30 × 50	55	22	70	9.41	4.80	B43540A2158M0*#
1500	35 × 40	60	24	75	9.20	4.69	B43540B2158M0*#
1800	35 × 45	50	20	65	10.3	5.30	B43540A2188M0*#
2200	35 × 55	40	17	50	12.10	6.17	B43540A2228M0*#
<b><math>V_R = 250</math> V DC</b>							
270	25 × 25	270	110	320	2.99	1.52	B43540E2277M0*#
330	25 × 30	220	90	260	3.46	1.76	B43540E2337M0*#
390	25 × 35	190	75	220	3.92	2.00	B43540E2397M0*#
390	30 × 25	180	65	210	3.91	1.99	B43540F2397M0*#
470	25 × 35	150	60	190	4.30	2.19	B43540E2477M0*#
470	30 × 30	150	55	180	4.49	2.29	B43540F2477M0*#
560	25 × 40	130	50	160	4.87	2.48	B43540E2567M0*#
560	30 × 30	120	45	150	4.90	2.50	B43540F2567M0*#
560	35 × 25	130	55	160	4.95	2.52	B43540G2567M0*#

**Composition of ordering code**

\* = Insulation feature

0 = PVC insulation

6 = PET insulation

8 = PVC insulation with additional PET insulation cap on terminal side

# = Terminal style

0 = snap-in standard terminals (6.3 mm)

2 = snap-in 3 terminals (4.5 mm)

7 = snap-in short terminals (4.5 mm)

 1) 120-Hz conversion factor of ripple current:  $I_{AC}(120\text{ Hz}) = 1.03 \cdot I_{AC}(100\text{ Hz})$

**B43540**
**Outstanding ripple current – 85 °C**
**Technical data and ordering codes**

$C_R$	Case dimensions	$ESR_{typ}$ 100 Hz	$ESR_{typ}$ 300 Hz	$Z_{max}$ 10 kHz	$I_{AC,max}$ 100 Hz	$I_{AC,R}^{(2)}$ 100 Hz	Ordering code (composition see below)
100 Hz	d × l	20 °C	60 °C	20 °C	60 °C	85 °C	
μF	mm	mΩ	mΩ	mΩ	A	A	
<b><math>V_R = 250</math> V DC</b>							
680	25 × 45	110	45	130	5.54	2.82	B43540E2687M0*#
680	30 × 35	100	40	120	5.62	2.87	B43540F2687M0*#
680	35 × 30	110	45	130	6.08	3.10	B43540G2687M0*#
820	25 × 55	90	36	110	6.42	3.27	B43540E2827M0*#
820	30 × 40	85	32	100	6.81	3.47	B43540F2827M0*#
820	35 × 35	90	36	110	6.93	3.54	B43540G2827M0*#
1000	30 × 45	70	26	85	7.76	3.96	B43540E2108M0*#
1000	35 × 35	75	30	90	7.66	3.90	B43540F2108M0*#
1200	30 × 55	60	22	70	8.97	4.58	B43540E2128M0*#
1200	35 × 40	60	26	75	8.68	4.43	B43540F2128M0*#
1500	35 × 50	50	20	60	10.2	5.25	B43540E2158M0*#
1800	35 × 55	40	17	50	11.5	5.89	B43540E2188M0*#
<b><math>V_R = 400</math> V DC</b>							
100	25 × 25	640	210	760	2.04	1.04	B43540A9107M0*#
120	25 × 30	510	170	600	2.34	1.19	B43540A9127M0*#
150	25 × 35	410	130	480	2.73	1.39	B43540A9157M0*#
150	30 × 25	420	130	490	2.72	1.39	B43540B9157M0*#
180	25 × 40	340	110	400	3.10	1.58	B43540A9187M0*#
180	30 × 30	330	110	390	3.12	1.59	B43540B9187M0*#
180	35 × 25	340	110	400	3.14	1.60	B43540C9187M0*#
220	25 × 40	290	100	340	3.43	1.75	B43540A9227M0*#
220	30 × 30	290	90	340	3.45	1.76	B43540B9227M0*#
220	35 × 30	280	95	330	3.86	1.97	B43540C9227M0*#
270	25 × 45	240	80	280	3.92	2.00	B43540A9277M0*#
270	30 × 35	230	75	270	3.98	2.03	B43540B9277M0*#
270	35 × 30	230	75	270	4.28	2.18	B43540C9277M0*#
330	25 × 55	190	65	230	4.58	2.33	B43540C9337M0*#
330	30 × 45	180	60	210	5.01	2.55	B43540A9337M0*#
330	35 × 35	190	60	220	4.92	2.51	B43540B9337M0*#
390	30 × 45	160	50	190	5.45	2.78	B43540A9397M0*#

**Composition of ordering code**

\* = Insulation feature

0 = PVC insulation

6 = PET insulation

8 = PVC insulation with additional PET insulation cap on terminal side

# = Terminal style

0 = snap-in standard terminals (6.3 mm)

2 = snap-in 3 terminals (4.5 mm)

7 = snap-in short terminals (4.5 mm)

 2) 120-Hz conversion factor of ripple current:  $I_{AC}(120\text{ Hz}) = 1.03 \cdot I_{AC}(100\text{ Hz})$

**Technical data and ordering codes**

$C_R$	Case dimensions	$ESR_{typ}$ 100 Hz	$ESR_{typ}$ 300 Hz	$Z_{max}$ 10 kHz	$I_{AC,max}$ 100 Hz	$I_{AC,R}^{(3)}$ 100 Hz	Ordering code (composition see below)
100 Hz	d × l	100 Hz	300 Hz	10 kHz	100 Hz	100 Hz	
20 °C	mm	20 °C	60 °C	20 °C	60 °C	85 °C	
μF		mΩ	mΩ	mΩ	A	A	
<b><math>V_R = 400</math> V DC</b>							
390	35 × 35	160	55	190	5.35	2.72	B43540B9397M0*#
470	30 × 50	130	40	160	6.15	3.14	B43540A9477M0*#
470	35 × 45	130	45	150	6.26	3.19	B43540B9477M0*#
560	35 × 50	110	36	130	7.03	3.58	B43540A9567M0*#
680	35 × 55	95	32	110	7.94	4.05	B43540A9687M0*#
<b><math>V_R = 450</math> V DC</b>							
68	25 × 25	1420	370	2030	1.56	0.80	B43540A5686M0*#
82	25 × 30	1180	310	1680	1.80	0.92	B43540A5826M0*#
100	25 × 30	970	250	1380	1.99	1.01	B43540A5107M0*#
100	30 × 25	960	250	1370	2.07	1.05	B43540B5107M0*#
120	25 × 35	810	210	1150	2.27	1.16	B43540A5127M0*#
120	30 × 30	800	210	1140	2.37	1.21	B43540B5127M0*#
150	25 × 35	710	190	1030	2.54	1.29	B43540A5157M0*#
150	30 × 30	640	160	910	2.65	1.35	B43540B5157M0*#
150	35 × 25	650	170	920	2.67	1.36	B43540C5157M0*#
180	25 × 45	540	140	770	2.97	1.51	B43540A5187M0*#
180	30 × 35	530	140	760	3.02	1.54	B43540B5187M0*#
180	35 × 30	540	140	770	3.32	1.69	B43540C5187M0*#
220	25 × 50	440	120	630	3.38	1.72	B43540A5227M0*#
220	30 × 40	440	110	620	3.76	1.92	B43540B5227M0*#
220	35 × 30	440	120	630	3.68	1.87	B43540C5227M0*#
270	25 × 55	400	100	570	3.85	1.96	B43540C5277M0*#
270	30 × 40	390	100	570	4.17	2.12	B43540A5277M0*#
270	35 × 35	360	100	510	4.23	2.16	B43540B5277M0*#
330	30 × 50	290	75	410	4.89	2.49	B43540A5337M0*#
330	35 × 40	290	80	420	4.84	2.47	B43540B5337M0*#
390	30 × 55	270	70	390	5.45	2.78	B43540B5397M0*#
390	35 × 45	250	65	350	5.43	2.77	B43540A5397M0*#
470	35 × 50	210	55	290	6.17	3.15	B43540A5477M0*#
560	35 × 55	190	50	280	6.86	3.50	B43540A5567M0*#

**Composition of ordering code**

\* = Insulation feature

0 = PVC insulation

6 = PET insulation

8 = PVC insulation with additional PET insulation cap on terminal side

# = Terminal style

0 = snap-in standard terminals (6.3 mm)

2 = snap-in 3 terminals (4.5 mm)

7 = snap-in short terminals (4.5 mm)

 3) 120-Hz conversion factor of ripple current:  $I_{AC}(120\text{ Hz}) = 1.03 \cdot I_{AC}(100\text{ Hz})$



**B43540**

**Outstanding ripple current – 85 °C**

**Useful life<sup>1)</sup>**

depending on ambient temperature  $T_A$  under ripple current operating conditions at  $V_R$

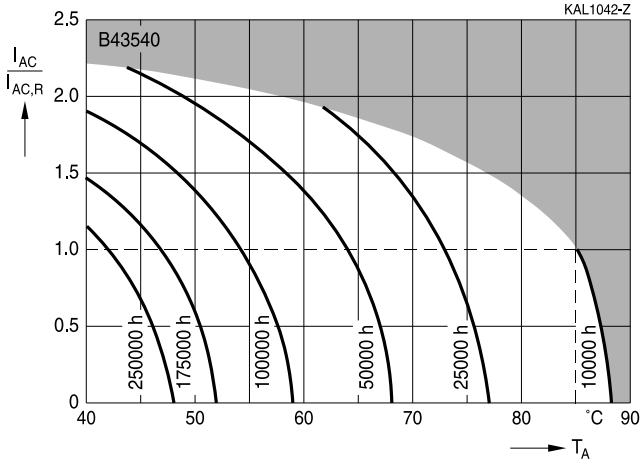

**Useful life<sup>1)</sup>**

depending on ambient temperature  $T_A$  under ripple current operating conditions at  $V_{op}$

$V_{op} \leq 0.93 \cdot V_R$

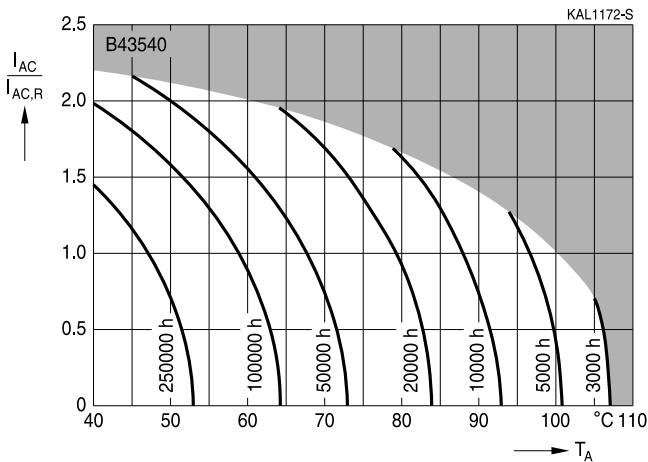

1) Refer to chapter "General technical information, 5 Useful life" on how to interpret useful life.



**Frequency factor of permissible ripple current  $I_{AC}$  versus frequency  $f$**

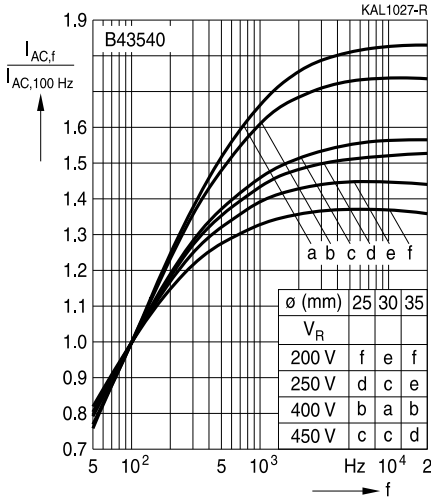

**Frequency characteristics of ESR**  
Typical behavior

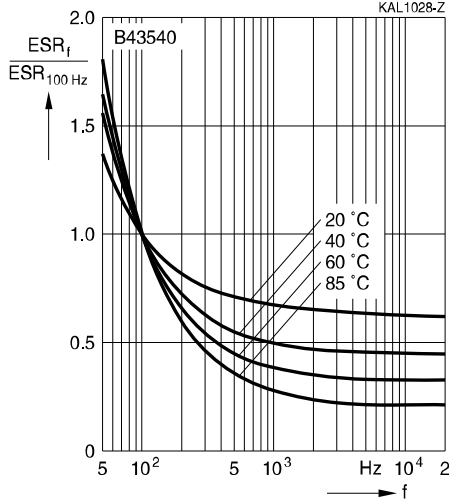

**Impedance  $Z$  versus frequency  $f$**   
Typical behavior at 20 °C

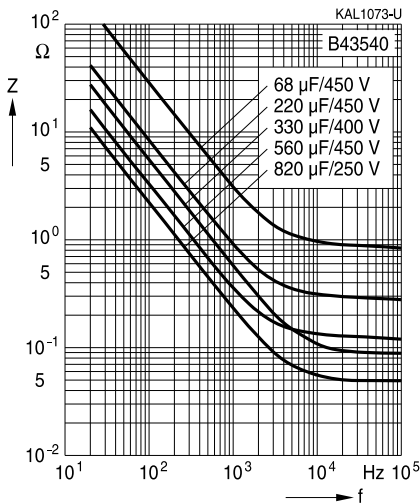



B43540

Outstanding ripple current – 85 °C

## Cautions and warnings

### Personal safety

The electrolytes used by EPCOS have been optimized both with a view to the intended application and with regard to health and environmental compatibility. They do not contain any solvents that are detrimental to health, e.g. dimethyl formamide (DMF) or dimethyl acetamide (DMAC).

Furthermore, some of the high-voltage electrolytes used by EPCOS are self-extinguishing.

As far as possible, EPCOS does not use any dangerous chemicals or compounds to produce operating electrolytes. However, in exceptional cases, such materials must be used in order to achieve specific physical and electrical properties because no alternative materials are currently known. However, the amount of dangerous materials used in our products is limited to an absolute minimum.

Materials and chemicals used in EPCOS aluminum electrolytic capacitors are continuously adapted in compliance with the EPCOS Corporate Environmental Policy and the latest EU regulations and guidelines such as RoHS, REACH/SVHC, GADSL, and ELV.

MDS (Material Data Sheets) are available on the EPCOS website for all types listed in the data book. MDS for customer specific capacitors are available upon request.

MSDS (Material Safety Data Sheets) are available for all of our electrolytes upon request.

Nevertheless, the following rules should be observed when handling aluminum electrolytic capacitors: No electrolyte should come into contact with eyes or skin. If electrolyte does come into contact with the skin, wash the affected areas immediately with running water. If the eyes are affected, rinse them for 10 minutes with plenty of water. If symptoms persist, seek medical treatment. Avoid inhaling electrolyte vapor or mists. Workplaces and other affected areas should be well ventilated. Clothing that has been contaminated by electrolyte must be changed and rinsed in water.



### Product safety

The table below summarizes the safety instructions that must be observed without fail. A detailed description can be found in the relevant sections of chapter "General technical information".

Topic	Safety information	Reference chapter "General technical information"
Polarity	Make sure that polar capacitors are connected with the right polarity.	1 "Basic construction of aluminum electrolytic capacitors"
Reverse voltage	Voltages polarity classes should be prevented by connecting a diode.	3.1.6 "Reverse voltage"
Mounting position of screw-terminal capacitors	Do not mount the capacitor with the terminals (safety vent) upside down.	11.1. "Mounting positions of capacitors with screw terminals"
Robustness of terminals	The following maximum tightening torques must not be exceeded when connecting screw terminals: M5: 2.5 Nm M6: 4.0 Nm	11.3 "Mounting torques"
Mounting of single-ended capacitors	The internal structure of single-ended capacitors might be damaged if excessive force is applied to the lead wires. Avoid any compressive, tensile or flexural stress. Do not move the capacitor after soldering to PC board. Do not pick up the PC board by the soldered capacitor. Do not insert the capacitor on the PC board with a hole space different to the lead space specified.	11.4 "Mounting considerations for single-ended capacitors"
Soldering	Do not exceed the specified time or temperature limits during soldering.	11.5 "Soldering"
Soldering, cleaning agents	Do not allow halogenated hydrocarbons to come into contact with aluminum electrolytic capacitors.	11.6 "Cleaning agents"
Upper category temperature	Do not exceed the upper category temperature.	7.2 "Maximum permissible operating temperature"
Passive flammability	Avoid external energy, such as fire or electricity.	8.1 "Passive flammability"

**B43540**
**Outstanding ripple current – 85 °C**

Topic	Safety information	Reference chapter "General technical information"
Active flammability	Avoid overload of the capacitors.	8.2 "Active flammability"
Maintenance	Make periodic inspections of the capacitors. Before the inspection, make sure that the power supply is turned off and carefully discharge the electricity of the capacitors. Do not apply any mechanical stress to the capacitor terminals.	10 "Maintenance"
Storage	Do not store capacitors at high temperatures or high humidity. Capacitors should be stored at +5 to +35 °C and a relative humidity of $\leq 75\%$ .	7.3 Storage conditions
		Reference chapter "Capacitors with screw terminals"
Breakdown strength of insulating sleeves	Do not damage the insulating sleeve, especially when ring clips are used for mounting.	"Screw terminals – accessories"

**Symbols and terms**

Symbol	English	German
C	Capacitance	Kapazität
$C_R$	Rated capacitance	Nennkapazität
$C_S$	Series capacitance	Serienkapazität
$C_{S,T}$	Series capacitance at temperature T	Serienkapazität bei Temperatur T
$C_f$	Capacitance at frequency f	Kapazität bei Frequenz f
d	Case diameter, nominal dimension	Gehäusedurchmesser, Nennmaß
$d_{max}$	Maximum case diameter	Maximaler Gehäusedurchmesser
ESL	Self-inductance	Eigeninduktivität
ESR	Equivalent series resistance	Ersatzserienwiderstand
$ESR_f$	Equivalent series resistance at frequency f	Ersatzserienwiderstand bei Frequenz f
$ESR_T$	Equivalent series resistance at temperature T	Ersatzserienwiderstand bei Temperatur T
f	Frequency	Frequenz
I	Current	Strom
$I_{AC}$	Alternating current (ripple current)	Wechselstrom
$I_{AC,rms}$	Root-mean-square value of alternating current	Wechselstrom, Effektivwert
$I_{AC,f}$	Ripple current at frequency f	Wechselstrom bei Frequenz f
$I_{AC,max}$	Maximum permissible ripple current	Maximal zulässiger Wechselstrom
$I_{AC,R}$	Rated ripple current	Nennwechselstrom
$I_{AC,R} (B)$	Rated ripple current for base cooling	Nennwechselstromstrom für Bodenkühlung
$I_{leak}$	Leakage current	Reststrom
$I_{leak,op}$	Operating leakage current	Betriebsreststrom
l	Case length, nominal dimension	Gehäuselänge, Nennmaß
$l_{max}$	Maximum case length (without terminals and mounting stud)	Maximale Gehäuselänge (ohne Anschlüsse und Gewindebolzen)
R	Resistance	Widerstand
$R_{ins}$	Insulation resistance	Isolationswiderstand
$R_{symm}$	Balancing resistance	Symmetrierwiderstand
T	Temperature	Temperatur
$\Delta T$	Temperature difference	Temperaturdifferenz
$T_A$	Ambient temperature	Umgebungstemperatur
$T_C$	Case temperature	Gehäusetemperatur
$T_B$	Capacitor base temperature	Temperatur des Becherbodens
t	Time	Zeit
$\Delta t$	Period	Zeitraum
$t_b$	Service life (operating hours)	Brauchbarkeitsdauer (Betriebszeit)

**B43540**
**Outstanding ripple current – 85 °C**

Symbol	English	German
V	Voltage	Spannung
V <sub>F</sub>	Forming voltage	Formierspannung
V <sub>op</sub>	Operating voltage	Betriebsspannung
V <sub>R</sub>	Rated voltage, DC voltage	Nennspannung, Gleichspannung
V <sub>S</sub>	Surge voltage	Spitzenspannung
X <sub>C</sub>	Capacitive reactance	Kapazitiver Blindwiderstand
X <sub>L</sub>	Inductive reactance	Induktiver Blindwiderstand
Z	Impedance	Scheinwiderstand
Z <sub>T</sub>	Impedance at temperature T	Scheinwiderstand bei Temperatur T
tan δ	Dissipation factor	Verlustfaktor
λ	Failure rate	Ausfallrate
ε <sub>0</sub>	Absolute permittivity	Elektrische Feldkonstante
ε <sub>r</sub>	Relative permittivity	Dielektrizitätszahl
ω	Angular velocity; $2 \cdot \pi \cdot f$	Kreisfrequenz; $2 \cdot \pi \cdot f$

**Note**

All dimensions are given in mm.

## Important notes

The following applies to all products named in this publication:

1. Some parts of this publication contain **statements about the suitability of our products for certain areas of application**. These statements are based on our knowledge of typical requirements that are often placed on our products in the areas of application concerned. We nevertheless expressly point out **that such statements cannot be regarded as binding statements about the suitability of our products for a particular customer application**. As a rule, EPCOS is either unfamiliar with individual customer applications or less familiar with them than the customers themselves. For these reasons, it is always ultimately incumbent on the customer to check and decide whether an EPCOS product with the properties described in the product specification is suitable for use in a particular customer application.
2. We also point out that **in individual cases, a malfunction of electronic components or failure before the end of their usual service life cannot be completely ruled out in the current state of the art, even if they are operated as specified**. In customer applications requiring a very high level of operational safety and especially in customer applications in which the malfunction or failure of an electronic component could endanger human life or health (e.g. in accident prevention or lifesaving systems), it must therefore be ensured by means of suitable design of the customer application or other action taken by the customer (e.g. installation of protective circuitry or redundancy) that no injury or damage is sustained by third parties in the event of malfunction or failure of an electronic component.
3. **The warnings, cautions and product-specific notes must be observed.**
4. In order to satisfy certain technical requirements, **some of the products described in this publication may contain substances subject to restrictions in certain jurisdictions (e.g. because they are classed as hazardous)**. Useful information on this will be found in our Material Data Sheets on the Internet ([www.epcos.com/material](http://www.epcos.com/material)). Should you have any more detailed questions, please contact our sales offices.
5. We constantly strive to improve our products. Consequently, **the products described in this publication may change from time to time**. The same is true of the corresponding product specifications. Please check therefore to what extent product descriptions and specifications contained in this publication are still applicable before or when you place an order. We also **reserve the right to discontinue production and delivery of products**. Consequently, we cannot guarantee that all products named in this publication will always be available. The aforementioned does not apply in the case of individual agreements deviating from the foregoing for customer-specific products.
6. Unless otherwise agreed in individual contracts, **all orders are subject to the current version of the "General Terms of Delivery for Products and Services in the Electrical Industry" published by the German Electrical and Electronics Industry Association (ZVEI)**.
7. The trade names EPCOS, BAOKE, Alu-X, CeraDiode, CeraLink, CeraPlas, CSMP, CSSP, CTVS, DeltaCap, DigiSiMic, DSSP, FilterCap, FormFit, MiniBlue, MiniCell, MKD, MKK, MLSC, MotorCap, PCC, PhaseCap, PhaseCube, PhaseMod, PhiCap, SIFERRIT, SIFI, SIKOREL, SilverCap, SIMDAD, SiMic, SIMID, SineFormer, SIOV, SIP5D, SIP5K, ThermoFuse, WindCap are **trademarks registered or pending** in Europe and in other countries. Further information will be found on the Internet at [www.epcos.com/trademarks](http://www.epcos.com/trademarks).