

This drawing involves proprietary design rights of Tyco Electronics Corporation, and all design, manufacture, reproduction, use and sale rights regarding the same are expressly reserved. It is submitted for a specific purpose and the recipient by accepting this drawing, assumes custody and control and agrees to take reasonable precautions; (a) that this drawing will not be copied and reproduced, in whole or in part, or its contents revealed in any manner, or to any person except to meet the purpose for which it was delivered and (b) that any special features peculiar to this design will not be incorporated in other projects without the expressed written permission of Tyco Electronics Corporation.

REVISIONS			
EC	REV	DESCRIPTION	DATE
CPR	A	NEW RELEASE	07/26/05

NOTES: UNLESS OTHERWISE SPECIFIED.

- PART NUMBER CHANGES AND OR DESIGN CHANGES AFFECTING ITEM INTERCHANGEABILITY REQUIRE PRIOR ELCON APPROVAL AND AUTHORIZATION BY REVISION TO THIS DRAWING.
- MATERIALS:
  - INSULATORS: THERMOPLASTIC, GLASS REINFORCED, COLOR BLACK. UL94V-0 FLAMMABILITY RATED.
  - COMPLIANT SIGNAL PIN: PHOSPHOR BRONZE ALLOY.
  - POWER CONTACTS: PHOSPHOR BRONZE ALLOY, COPPER ALLOY.
  - CROWN BANDS: BERYLLIUM COPPER ALLOY.
  - GUIDE PIN: BRASS COPPER ALLOY.
- FINISHES:
  - CONTACTS: GOLD PLATED PER MIL-G-45204 TYPE II, CLASS 0, .000030" MIN. THK, OVER NICKEL PER QQ-N-290, CLASS 2, .000040" MIN. THICKNESS.
  - TERMINALS: TIN PLATED, MATTE FINISH, .000040" MINIMUM THICKNESS.
  - GUIDE PIN: NICKEL PLATED PER AMS 2404.
- ITEMS PROVIDED TO THIS SPECIFICATION TO BE PERMANENTLY IDENTIFIED PER THE FOLLOWING IDENTIFIER:

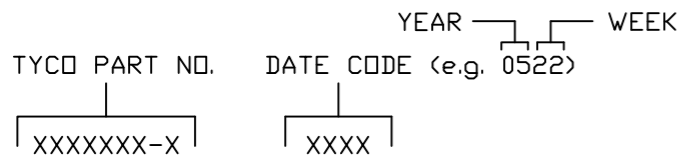

5. MODULE INFORMATION

CONNECTOR	TYCO PART NUMBER	CATALOG MODULE #	SIZE NO.	CONTACT QTY	MATING PIN	MAX. CURRENT (PER CONTACT)	CONTACT SPACING	VOLTAGE RATING*
SOCKET	1766706-1	FP710	8	5	1.25 X 7.00 [.049 X .276]	35 AMPERES	7.50 [L2953]	250 VOLTS
			22	24	.64 [L025] SQ.	3 AMPERES	2.50 [L0984]	125 VOLTS
			STRAIGHT GUIDE PIN					

\*IAW IEC-950

<p>THIRD ANGLE PROJECTION</p> <p>UNLESS OTHERWISE SPECIFIED DIMENSIONS ARE IN METRIC [INCHES]</p> <p>TOLERANCES</p> <p>ANGLES ± .5°</p> <p>DECIMALS</p> <p>.XX ± .25 [.010]</p> <p>.X ± .5 [.020]</p>	<p>DRAWN</p> <p>R. F. A.</p>	<p>DATE</p> <p>07/22/05</p>	<p><b>tyco</b> Tyco Electronics Corporation <b>Electronics</b> Menlo Park, Ca 94025</p> <p><b>ELCON</b></p>		
	CHECKED		TITLE		
	APPROVED		CONNECTOR, SOCKET, STRAIGHT STD SOLDER TAILS, FLATPAQ PN 1766706-1		
	APPROVED		SIZE	DWG NUMBER	REV.
	D. CHAU	08/03/05	B	C = 1766706	A
	M. ALIM	08/03/05			
	ACAD FILE NUMBER C1766706A.DWG		DWG SCALE 1=1		SH 1 OF 3

This drawing involves proprietary design rights of Tyco Electronics Corporation, and all design, manufacture, reproduction, use and sale rights regarding the same are expressly reserved. It is submitted for a specific purpose and the recipient by accepting this drawing, assumes custody and control and agrees to take reasonable precautions; (a) that this drawing will not be copied and reproduced, in whole or in part, or its contents revealed in any manner, or to any person except to meet the purpose for which it was delivered and (b) that any special features peculiar to this design will not be incorporated in other projects without the expressed written permission of Tyco Electronics Corporation.

REVISIONS			
EC	REV	DESCRIPTION	DATE
		SEE SHEET 1	

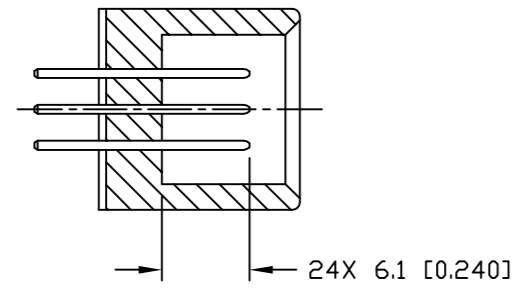
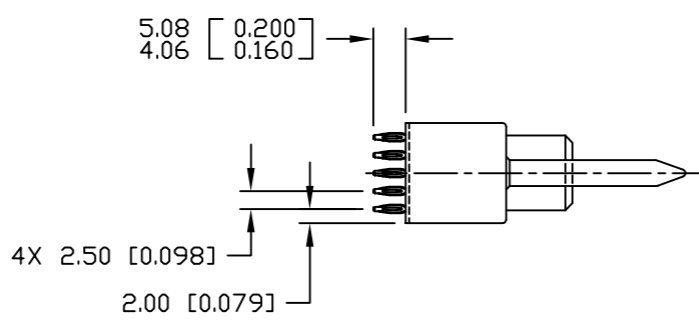

SECTION A-A

GENDER CHANGER NOT SHOWN FOR CLARITY

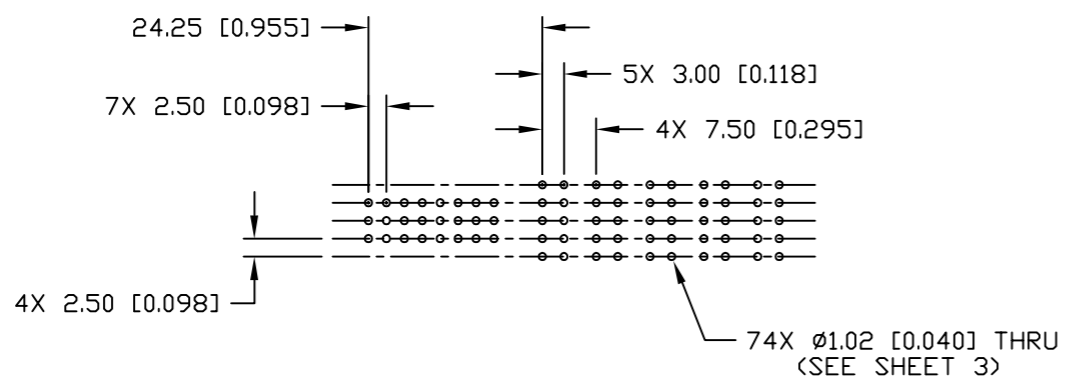
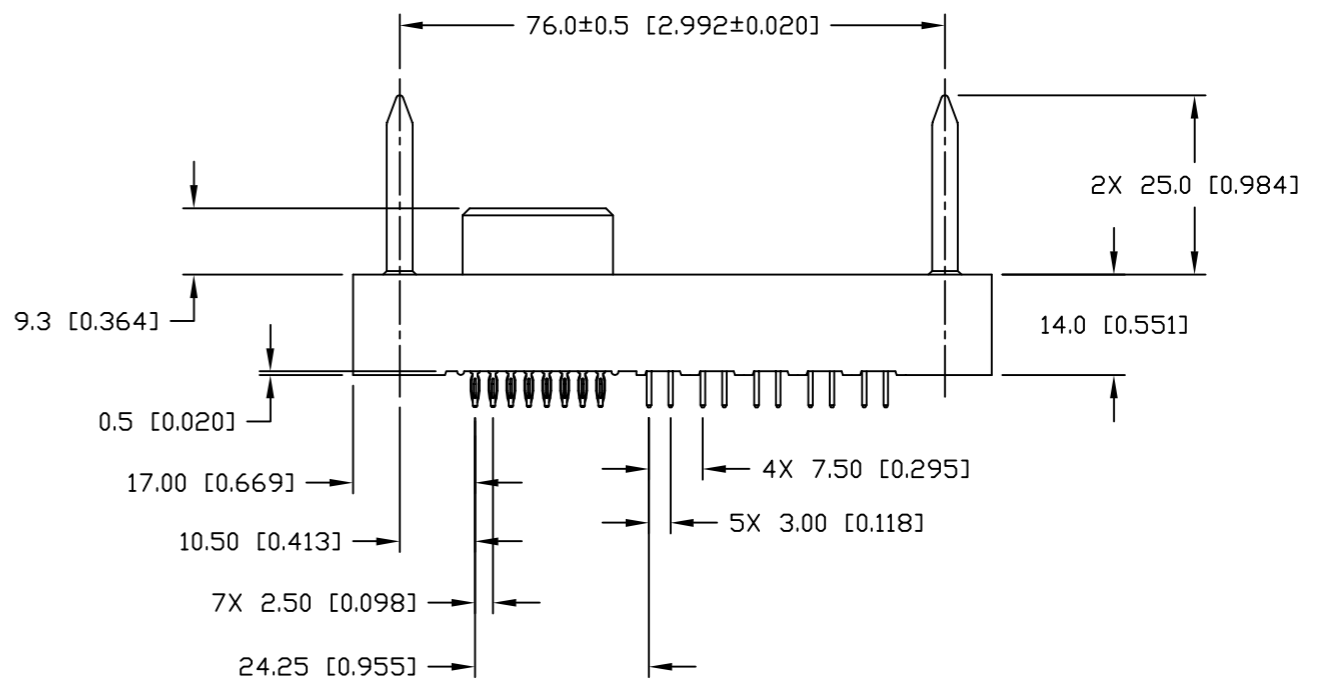
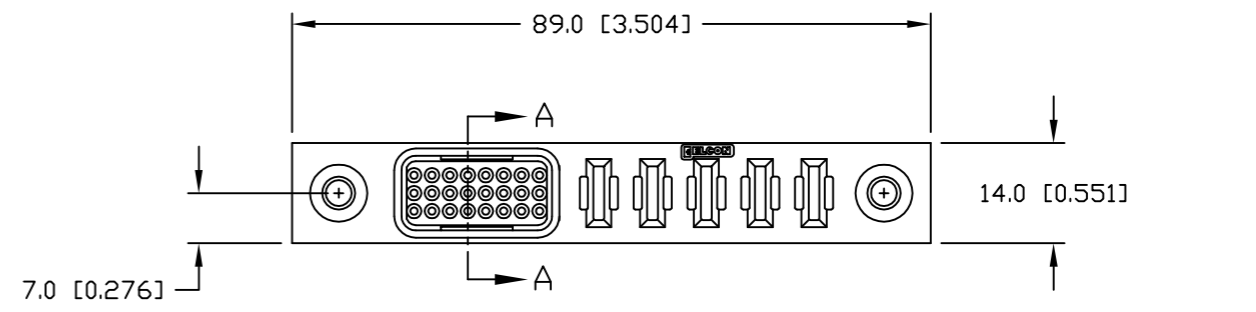

PRINTED CIRCUIT LAYOUT

MM INCH  THIRD ANGLE PROJECTION UNLESS OTHERWISE SPECIFIED DIMENSIONS ARE IN METRIC [INCHES] TOLERANCES ANGLES ± .5° DECIMALS .XX ± .25 [.010] .X ± .5 [.020]	DRAWN R. F. A.	DATE 07/22/05	 Tyco Electronics Corporation Menlo Park, Ca 94025 
	CHECKED	APPROVED	
	APPROVED D. CHAU	08/03/05	SIZE DWG NUMBER REV. B C = 1766706 A
	DCA APPROVED M. ALIM	08/03/05	
	ACAD FILE NUMBER C1766706A.DWG		DWG SCALE 1=1 SH 2 OF 3

This drawing involves proprietary design rights of Tyco Electronics Corporation, and all design, manufacture, reproduction, use and sale rights regarding the same are expressly reserved. It is submitted for a specific purpose and the recipient by accepting this drawing, assumes custody and control and agrees to take reasonable precautions; (a) that this drawing will not be copied and reproduced, in whole or in part, or its contents revealed in any manner, or to any person except to meet the purpose for which it was delivered and (b) that any special features peculiar to this design will not be incorporated in other projects without the expressed written permission of Tyco Electronics Corporation.

REVISIONS

EC	REV	DESCRIPTION	DATE
		SEE SHEET 1	

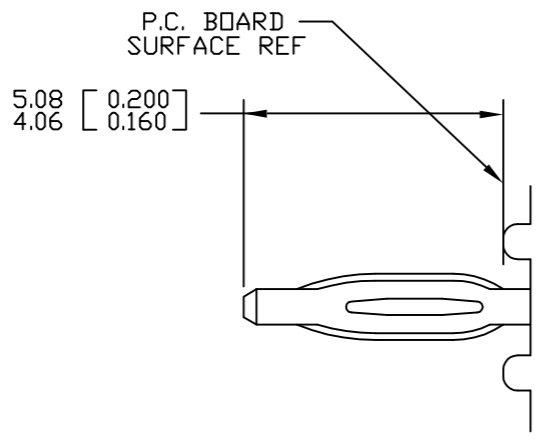

COMPLIANT PIN DETAIL

INSERTION/EXTRACTION FORCES  
 MAXIMUM PUSH-IN: 133.3N PER PIN [30 LBS]  
 MINIMUM PUSH-OUT: 44.4N PER PIN [10 LBS]

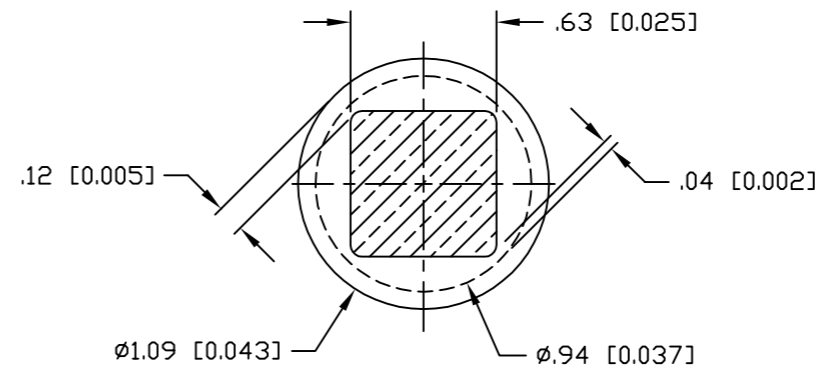

SOLDER TERMINATION AREA

RECOMMENDED PRINTED CIRCUIT HOLE  
 FINISHED HOLE: Ø1.02 [0.040] ±.08 [0.003]  
 DRILLED HOLE: Ø1.15 [0.0453] ±.013 [0.0005]  
 COPPER PLATE: .025 [0.0010] MINIMUM (PER SURFACE)  
 TIN PLATE: .008 [0.0003] MINIMUM (PER SURFACE)

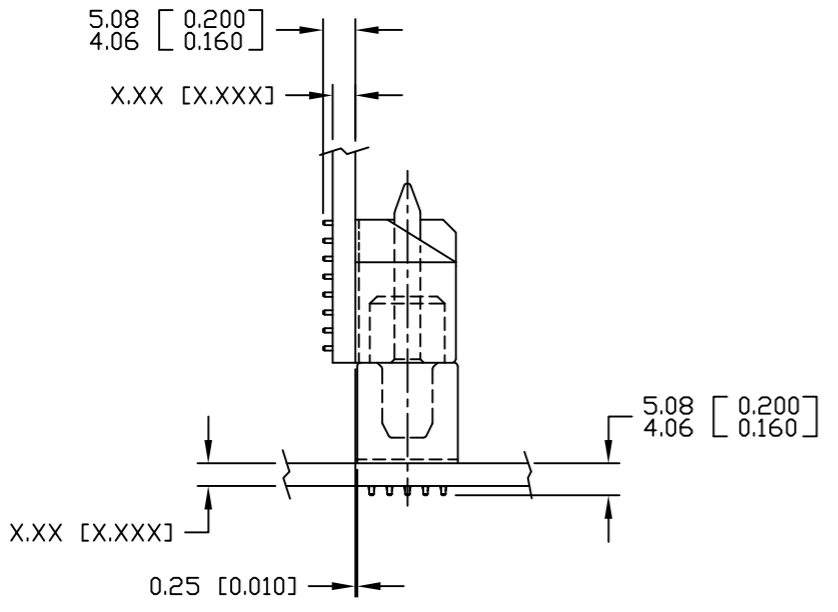

MATED CONDITION

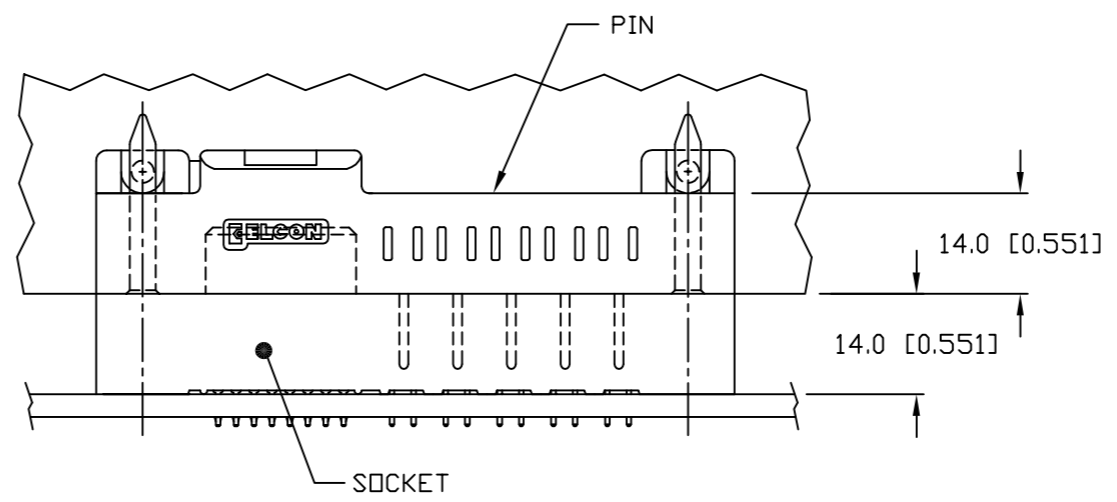

MM INCH OR MM [INCH]	DRAWN R. F. A.	DATE 07/22/05	<b>tyco</b> Tyco Electronics Corporation <b>Electronics</b> Menlo Park, Ca 94025		ELCON
	CHECKED		TITLE USER INFORMATION SOLDER TAIL TERMINATION AND MATED CONDITION		
THIRD ANGLE PROJECTION	APPROVED		SIZE B	DWG NUMBER C = 1766706	REV. A
UNLESS OTHERWISE SPECIFIED DIMENSIONS ARE IN METRIC [INCHES]	APPROVED D. CHAU	08/03/05			
TOLERANCES ANGLES ± .5°	DCA APPROVED M. ALIM	08/03/05			
DECIMALS .XX ± .25 [.010] .X ± .5 [.020]	ACAD FILE NUMBER C1766706A.DWG		DWG SCALE 1 = 1	SH 3 OF 3	