

TAS5806MEVM User's Guide

This user's guide describes the operation of the TAS5806M Evaluation Module (EVM). The EVM is connected to the PurePath™ Console Motherboard (PPCMB). The main contents of this document are:

- Hardware descriptions and implementation

Required equipment and accessories:

- TAS5806MEVM
- PurePath Console Motherboard
- A USB micro type-B cable
- Power supply unit (PSU)
- Speakers and cables
- Desktop or laptop running Microsoft® Windows® 7, Windows 8, or Windows 8.1
- Audio source: This can be a DVD player with appropriate SPDIF cable or *Playback Media* from Windows 7, Windows 8 or Windows 8.1.

Trademarks

PurePath is a trademark of Texas Instruments.

Microsoft, Windows are registered trademarks of Microsoft Corporation.

All other trademarks are the property of their respective owners.

1 Hardware Overview

The TAS5806MEVM showcases the latest TI digital input Class-D closed-loop amplifier. The TAS5806M is an inductor-less digital input stereo Class-D audio amplifier with enhanced processing and low power dissipation. The EVM is used in conjunction with the PurePath Console Motherboard (PPCMB). The PVDD supply is provided via the TAS5806MEVM (Figure 1) and is regulated to 5 VDC and 3.3 VDC on the PPCMB. The PPCMB provides the I²S, I²C, and 3.3 VDC to the TAS5806MEVM.

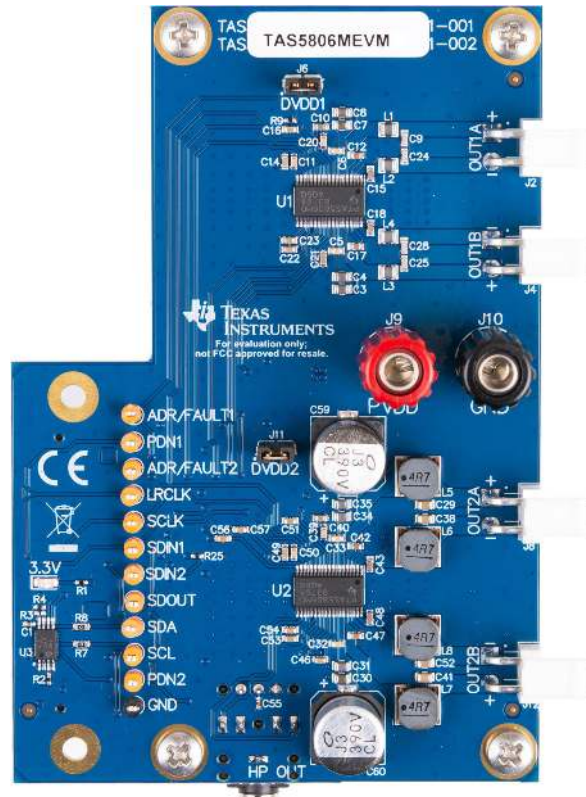

Figure 1. TAS5806MEVM

1.1 Features

The EVM has the following features:

- 96-kHz input sample rate support
- 2.0, mono and 2.1 capable
- Operates in BTL or PBTL
- PurePath Console Motherboard provides flexible input signal routing (USB, SPDIF, and analog)
- Demonstration, evaluation and development environment via the PurePath Console 3 software (GUI)

1.2 Functions

The TAS5806MEVM is controlled by the PPCMB. The digital audio data input to the TAS5806MEVM is sent from PPCMB and is selectable from USB audio, optical SPDIF, coaxial SPDIF, PSIA (external I²S) and analog ADC sources.

1.3 Detailed Operations

Upon power-on, the PPCMB uses USB audio input (default). The I²S signals LRCLK, SCLK, SDIN and MCLK come from the TAS1020B.

foobar2000 or similar non-processing media source can be used to stream audio. The TAS1020B enumerates as the following device on a Microsoft Windows operating system (OS): USB audio (USB-AudioEVM) (See [Figure 2](#)).

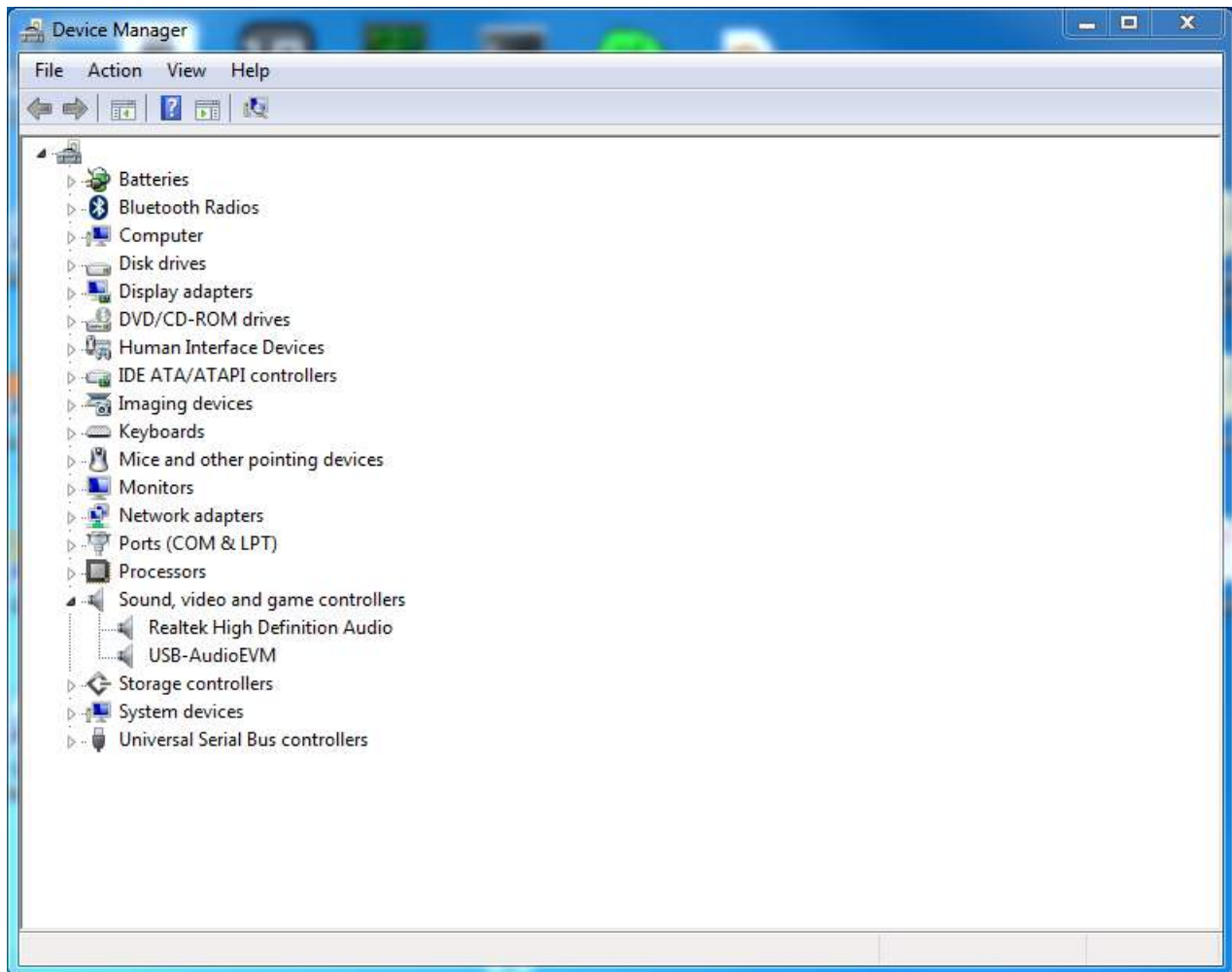

Figure 2. Device Manager

USB audio output quality can be configured as shown in Figure 3. Users must select "2 channel, 16 bit, 48000 Hz (DVD Quality)".

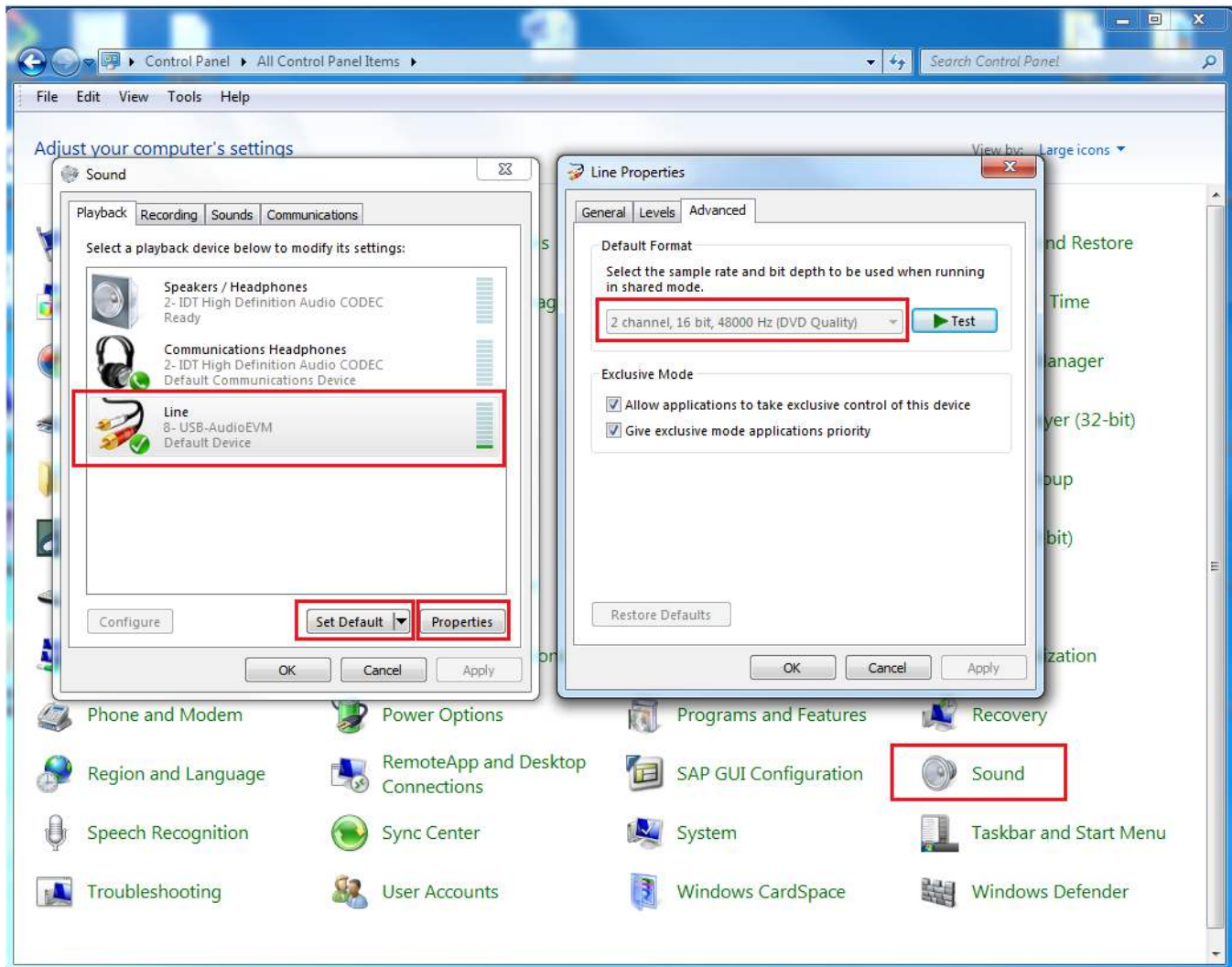

Figure 3. Default Format

2 Hardware Setup

Use the following steps when setting up the hardware:

- Step 1. Connect the PPCMB to the TAS5806MEVM.
- Step 2. Connect speakers to the TAS5806MEVM.
- Step 3. Connect a PSU to the TAS5806MEVM and turn on the power. 5-V and 3.3-V LEDs (Yellow) are illuminated. The USB Lock LED (Blue) is also illuminated.
- Step 4. Plug in a USB cable from the PC to the PPCMB.
- Step 5. If an optical SPDIF source is used, the blue SPDIF clock-locked LED is illuminated.

2.1 I²C Device Addresses

The default I²C addresses on the EVM are set to 0x58 for the top device (U1) and 0x5A for the bottom one (U2).

3 Troubleshooting

3.1 Power Cycle

To perform a power cycle, disconnect both the USB cable and the power supply from the board.

4 Board Layouts, Bill of Materials, and Schematic

This section includes the EVM schematics, board layouts and bill of materials.

4.1 Schematics

Figure 4 to Figure 6 illustrate the schematics for this EVM.

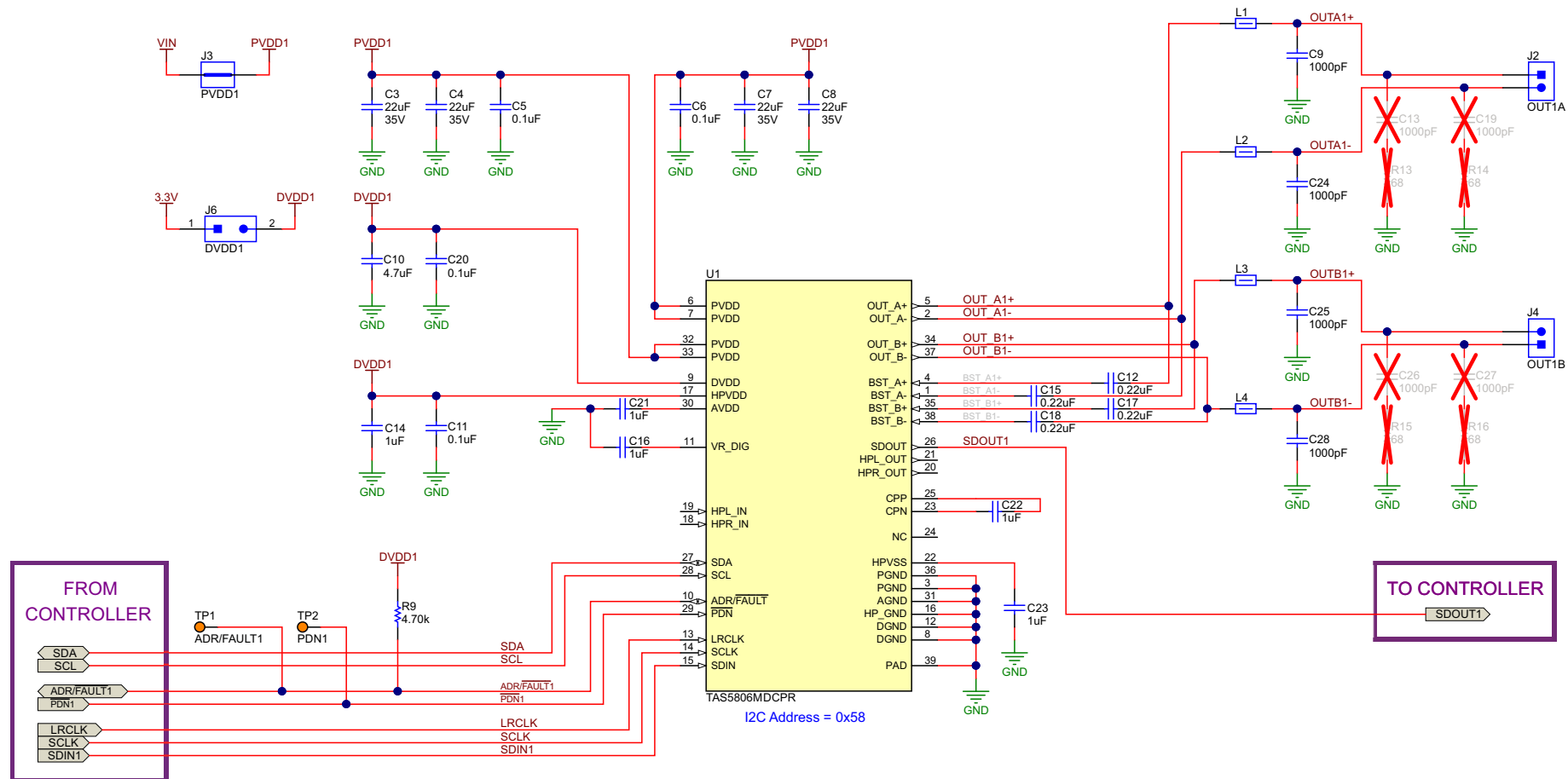

Figure 4. TAS5806MEVM Schematic (1 of 3)

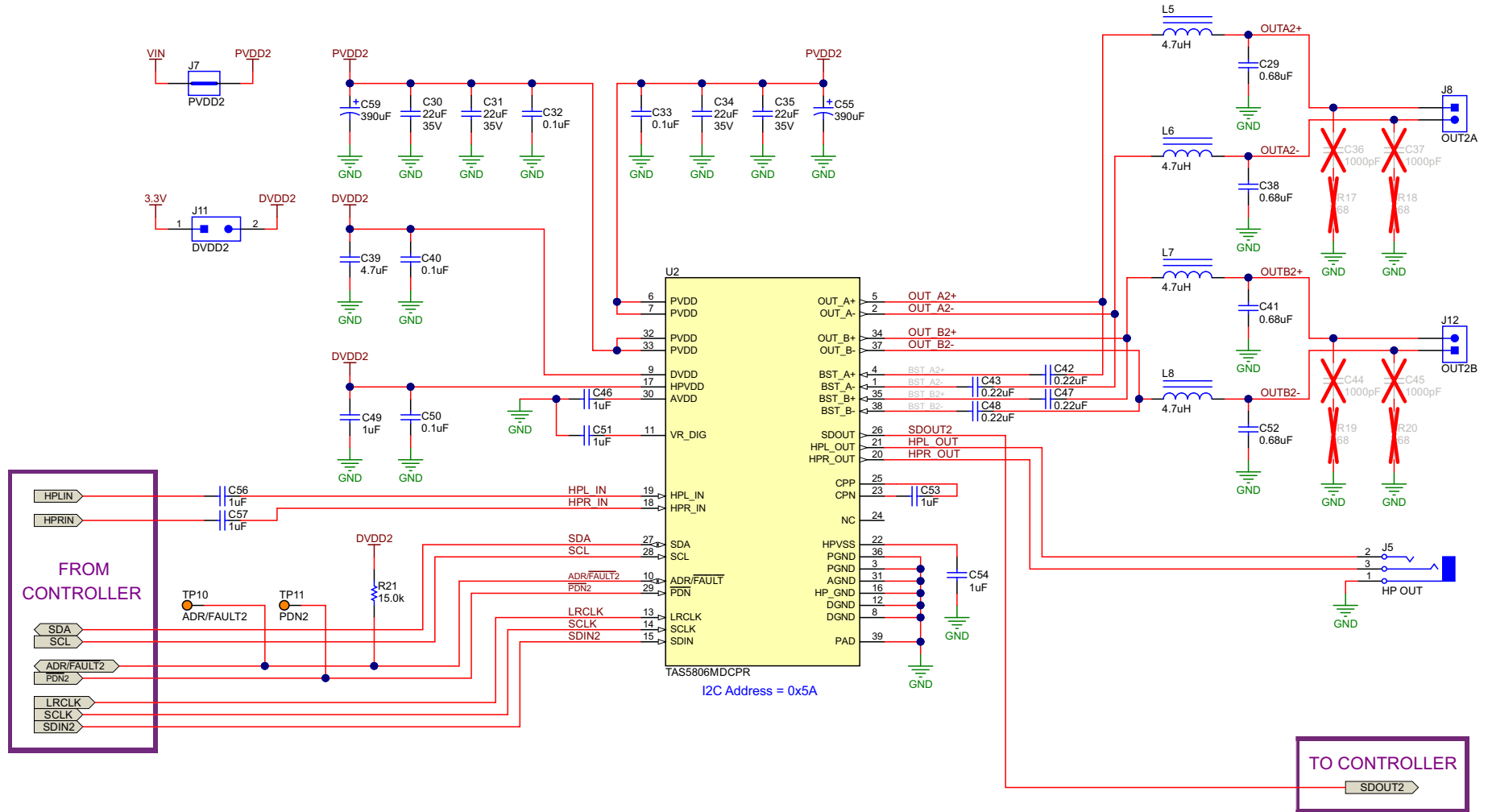

Figure 5. TAS5806MEVM Schematic (2 of 3)

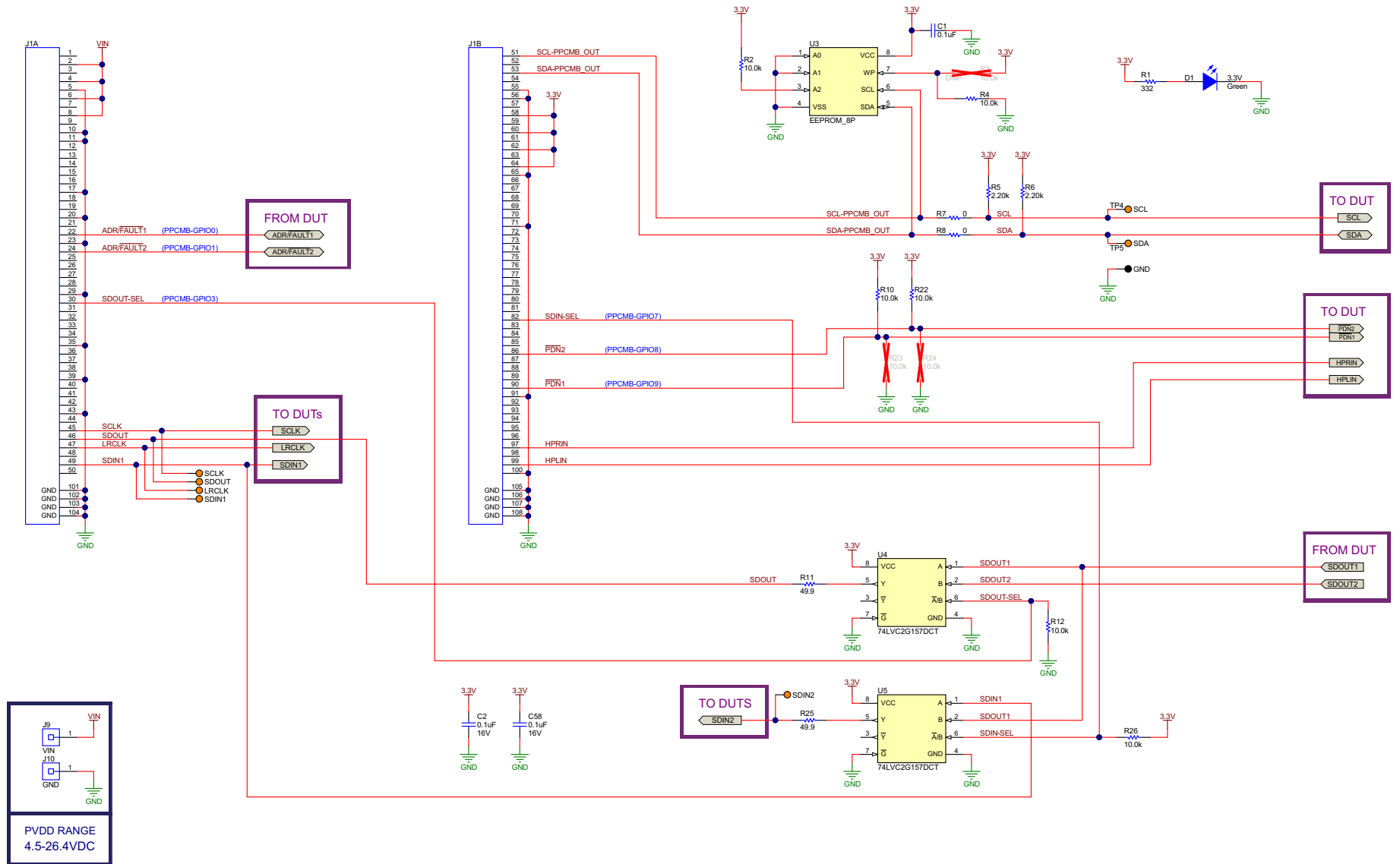

Figure 6. TAS5806MEVM Schematic (3 of 3)

4.2 Board Layouts

Figure 7 and Figure 8 illustrate the board layouts for the EVM.

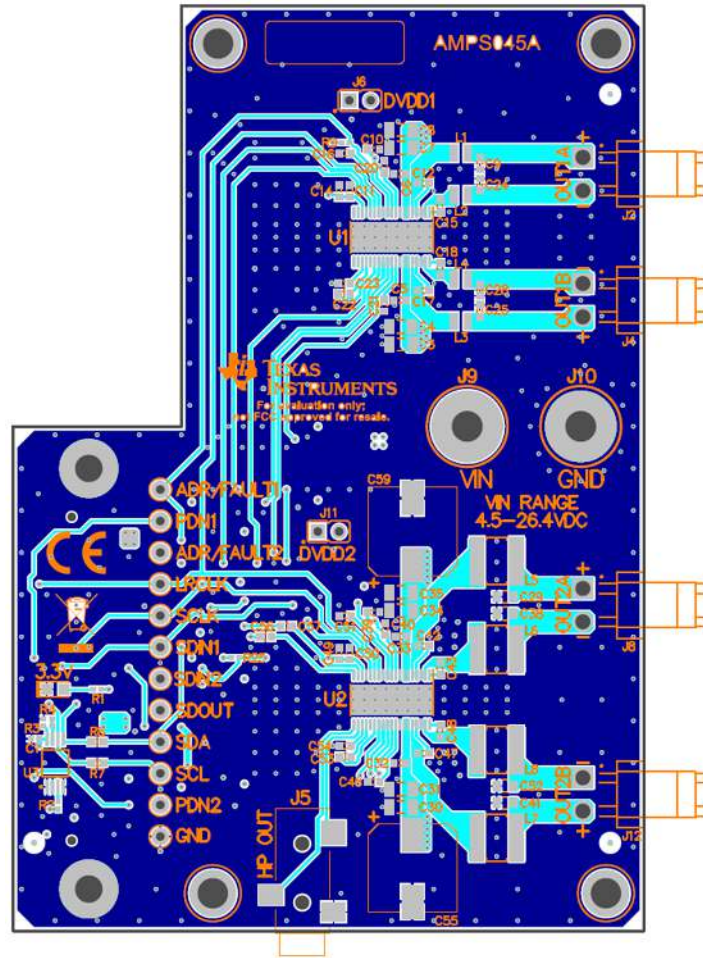

Figure 7. TAS5806MEVM Top Composite Assembly

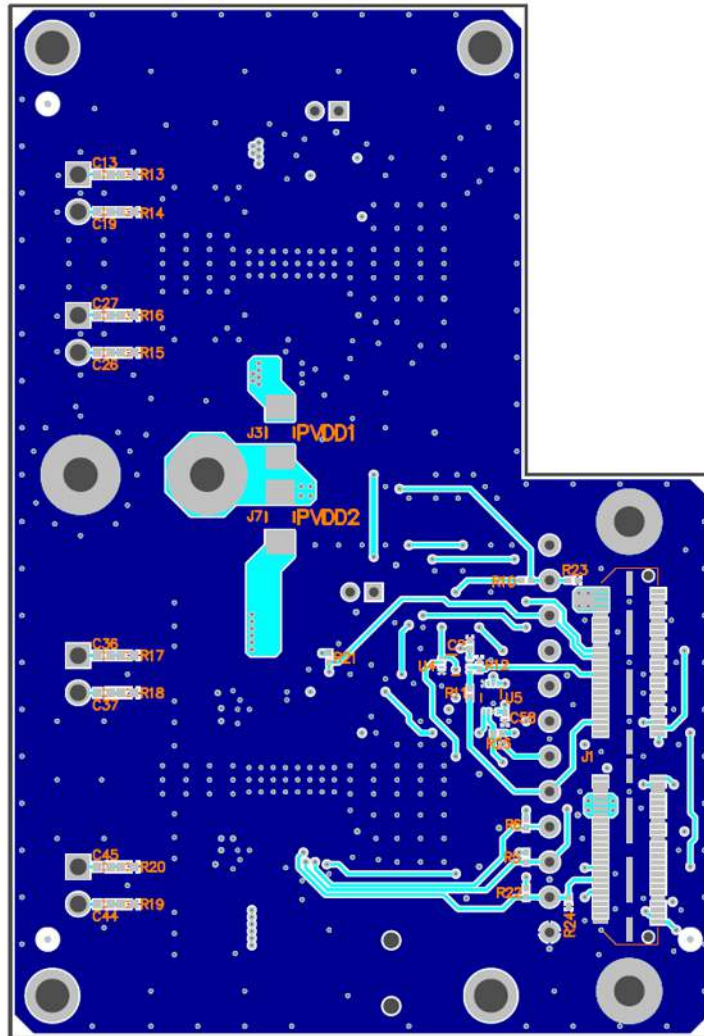

Figure 8. TAS5806MEVM Bottom Composite Assembly

4.3 Bill of Materials

Table 1 details the EVM BOM.

Table 1. Bill of Materials⁽¹⁾

Designator	Qty	Value	Description	Package Reference	Part Number	Manufacturer	Alternate Part Number	Alternate Manufacturer
C1, C2, C58	3	0.1uF	CAP, CERM, 0.1 uF, 16 V, +/- 10%, X7R, 0402	0402	GCM155R71C104KA55D	MuRata		
C3, C4, C7, C8, C30, C31, C34, C35	8	22uF	CAP, CERM, 22 uF, 35 V, +/- 20%, X5R, 1206	1206	C3216X5R1V226M160AC	TDK		
C5, C6, C11, C20, C32, C33, C40, C50	8	0.1uF	CAP, CERM, 0.1 uF, 16 V, +/- 10%, X7R, 0603	0603	C0603C104K4RACTU	Kemet		
C9, C24, C25, C28	4	1000pF	CAP, CERM, 1000 pF, 50 V, +/- 10%, C0G/NP0, 0603	0603	06035A102KAT2A	AVX		
C10, C39	2	4.7uF	CAP, CERM, 4.7 uF, 10 V, +/- 10%, X5R, 0603	0603	C0603C475K8PACTU	Kemet		
C12, C15, C17, C18, C42, C43, C47, C48	8	0.22uF	CAP, CERM, 0.22 uF, 50 V, +/- 10%, X7R, AEC-Q200 Grade 1, 0603	0603	CGA3E3X7R1H224K080AB	TDK		
C14, C16, C21, C22, C23, C46, C49, C51, C53, C54, C56, C57	12	1uF	CAP, CERM, 1 uF, 16 V, +/- 10%, X5R, 0603	0603	C0603C105K4PACTU	Kemet		
C29, C38, C41, C52	4	0.68uF	CAP, CERM, 0.68 uF, 50 V, +/- 10%, X7R, 0805	0805	C0805C684K5RACTU	Kemet		
C55, C59	2	390uF	CAP, AL, 390 uF, 35 V, +/- 20%, 0.08 ohm, SMD	10x10	UCL1V391MNL1GS	Nichicon		
D1	1	Green	LED, Green, SMD	LED_0805	LTST-C170KGKT	Lite-On		
H1, H2, H3, H4	4		MACHINE SCREW PAN PHILLIPS M3	M3 Screw	RM3X8MM 2701	APM HEXSEAL		
H5, H6, H7, H8	4		Washer, Flat, #4 Nylon		3200	Keystone		
H9, H10, H11, H12	4		Standoff, HexBrass M3, 30 mm	Spacer M3, 30mm	R30-1003002	Harwin		
J1	1		Connector, 100 Pos. 0.635mm, SMT	Connector, 1575x235x280 mil	QTS-050-01-F-D-A	Samtec		
J2, J4, J8, J12	4		Header (friction lock), 3.96mm, 2x1, Tin, R/A, TH	Header, 2x1, 3.96mm, R/A	B2PS-VH(LF)(SN)	JST Manufacturing		
J3, J7	2		JUMPER TIN SMD	6.85x0.97x2.51 mm	S1911-46R	Harwin		
J5	1		Audio Jack, 3.5mm, Stereo, R/A, SMT	Audio Jack SMD	SJ-3523-SMT	CUI Inc.		
J6, J11	2		Header, 100mil, 2x1, Gold, TH	Sullins 100mil, 1x2, 230 mil above insulator	PBC02SAAN	Sullins Connector Solutions		
J9	1		Binding Post, RED, TH	11.4x27.2mm	7006	Keystone		
J10	1		Binding Post, BLACK, TH	11.4x27.2mm	7007	Keystone		
L1, L2, L3, L4	4	300 ohm	Ferrite Bead, 300 ohm @ 100 MHz, 3.1 A, 0806	0806	NFZ2MSM301SN10L	MuRata		
L5, L6, L7, L8	4	4.7uH	Inductor, Shielded, 4.7 uH, 4 A, 0.023 ohm, SMD	6.3x4.5x6.3mm	1255AY-4R7M=P3	MuRata Toko		
LBL1	1		Thermal Transfer Printable Labels, 0.650" W x 0.200" H - 10,000 per roll	PCB Label 0.650 x 0.200 inch	THT-14-423-10	Brady		
R1	1	332	RES, 332, 1%, 0.063 W, AEC-Q200 Grade 0, 0402	0402	CRCW0402332RFKED	Vishay-Dale		
R2, R4, R10, R22	4	10.0k	RES, 10.0 k, 1%, 0.063 W, AEC-Q200 Grade 0, 0402	0402	CRCW040210K0FKED	Vishay-Dale		
R5, R6	2	2.20k	RES, 2.20 k, 1%, 0.063 W, AEC-Q200 Grade 0, 0402	0402	CRCW04022K20FKED	Vishay-Dale		
R7, R8	2	0	RES, 0, 5%, 0.1 W, AEC-Q200 Grade 0, 0603	0603	CRCW06030000Z0EA	Vishay-Dale		
R9	1	4.70k	RES, 4.70 k, 1%, 0.1 W, 0402	0402	ERJ-2RKF4701X	Panasonic		
R11, R25	2	49.9	RES, 49.9, 1%, 0.063 W, 0402	0402	RC0402FR-0749R9L	Yageo America		

⁽¹⁾ Unless otherwise noted in the *Alternate Part Number* or *Alternate Manufacturer* columns, all parts may be substituted with equivalents.

Table 1. Bill of Materials⁽¹⁾ (continued)

Designator	Qty	Value	Description	Package Reference	Part Number	Manufacturer	Alternate Part Number	Alternate Manufacturer
R12, R26	2	10.0k	RES, 10.0 k, 1%, 0.063 W, AEC-Q200 Grade 0, 0402	0402	RMCF0402FT10K0	Stackpole Electronics Inc		
R21	1	15.0k	RES, 15.0 k, .1%, .063 W, AEC-Q200 Grade 0, 0402	0402	ERA-2AEB153X	Panasonic		
SH-J1, SH-J2	2	1x2	Shunt, 100mil, Gold plated, Black	Shunt	SNT-100-BK-G	Samtec	969102-0000-DA	3M
TP1, TP2, TP4, TP5, TP6, TP7, TP8, TP9, TP10, TP11, TP12	11		Test Point, Miniature, Orange, TH	Orange Miniature Testpoint	5003	Keystone		
TP3	1		Test Point, Miniature, Black, TH	Black Miniature Testpoint	5001	Keystone		
U1, U2	2		20W Inductor-Less, Digital Input, Stereo, Closed-Loop Class-D Audio Amplifier with Enhanced Processing and DirectPath HP Driver, DCP0038A (TSSOP-38)	DCP0038A	TAS5806MDCPR	Texas Instruments	TAS5806MDCPT	Texas Instruments
U3	1		EEPROM, 512KBIT, 400KHZ, 8TSSOP	TSSOP-8	24LC512-I/ST	Microchip		
U4, U5	2		Single 2-Line to 1-Line Data Selector/Multiplexer, DCU0008A, LARGE T&R	DCU0008A	'SN74LVC2G157DCUR	Texas Instruments	SN74LVC2G157DCUT	Texas Instruments
C13, C19, C26, C27, C36, C37, C44, C45	0	1000pF	CAP, CERM, 1000 pF, 50 V, +/- 10%, C0G/NP0, 0603	0603	06035A102KAT2A	AVX		
FID1, FID2, FID3, FID4, FID5, FID6	0		Fiducial mark. There is nothing to buy or mount.	N/A	N/A	N/A		
R3, R23, R24	0	10.0k	RES, 10.0 k, 1%, 0.063 W, AEC-Q200 Grade 0, 0402	0402	CRCW040210K0FKED	Vishay-Dale		
R13, R14, R15, R16, R17, R18, R19, R20	0	68	RES, 68, 5%, 0.1 W, AEC-Q200 Grade 0, 0603	0603	CRCW060368R0JNEA	Vishay-Dale		

IMPORTANT NOTICE AND DISCLAIMER

TI PROVIDES TECHNICAL AND RELIABILITY DATA (INCLUDING DATA SHEETS), DESIGN RESOURCES (INCLUDING REFERENCE DESIGNS), APPLICATION OR OTHER DESIGN ADVICE, WEB TOOLS, SAFETY INFORMATION, AND OTHER RESOURCES "AS IS" AND WITH ALL FAULTS, AND DISCLAIMS ALL WARRANTIES, EXPRESS AND IMPLIED, INCLUDING WITHOUT LIMITATION ANY IMPLIED WARRANTIES OF MERCHANTABILITY, FITNESS FOR A PARTICULAR PURPOSE OR NON-INFRINGEMENT OF THIRD PARTY INTELLECTUAL PROPERTY RIGHTS.

These resources are intended for skilled developers designing with TI products. You are solely responsible for (1) selecting the appropriate TI products for your application, (2) designing, validating and testing your application, and (3) ensuring your application meets applicable standards, and any other safety, security, regulatory or other requirements.

These resources are subject to change without notice. TI grants you permission to use these resources only for development of an application that uses the TI products described in the resource. Other reproduction and display of these resources is prohibited. No license is granted to any other TI intellectual property right or to any third party intellectual property right. TI disclaims responsibility for, and you will fully indemnify TI and its representatives against, any claims, damages, costs, losses, and liabilities arising out of your use of these resources.

TI's products are provided subject to [TI's Terms of Sale](#) or other applicable terms available either on ti.com or provided in conjunction with such TI products. TI's provision of these resources does not expand or otherwise alter TI's applicable warranties or warranty disclaimers for TI products.

TI objects to and rejects any additional or different terms you may have proposed.

Mailing Address: Texas Instruments, Post Office Box 655303, Dallas, Texas 75265
Copyright © 2022, Texas Instruments Incorporated