

# Cell Type 2CR-1/3N Specifications

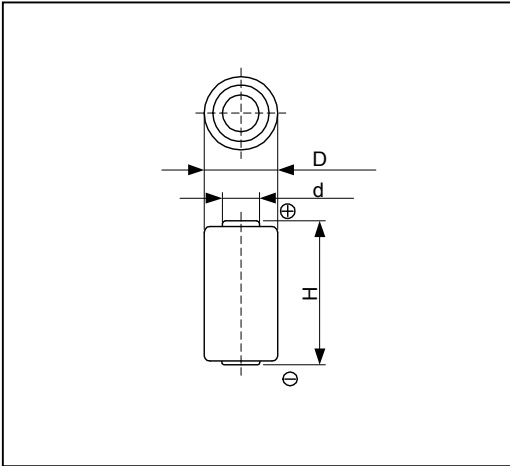

Nominal Capacity <sup>*1</sup>		160mAh
Nominal Voltage		6V
Standard Discharge Current		2mA
Max. Discharge Current	Continuous <sup>*2</sup>	60mA
	Pulse <sup>*3</sup>	80mA
Temperature Range		-40°C ~ 60°C
Weight		9.1g
Dimensions	D	13.0mm
	H	25.2mm
	d	6.3mm

\*1 Nominal capacity is determined to an end voltage of 4.0V when the battery is allowed to discharge at a standard current level at 23°C.

\*2 Current value is determined to be the level at which 50% of the nominal capacity is obtained with an end voltage of 4.0V at 23 °C.

\*3 Current value for obtaining 4.0V cell voltage when pulse is applied for 15seconds at 50% discharge depth at 23 °C.

## Typical Characteristics

Discharge Characteristics of 2CR1/3N

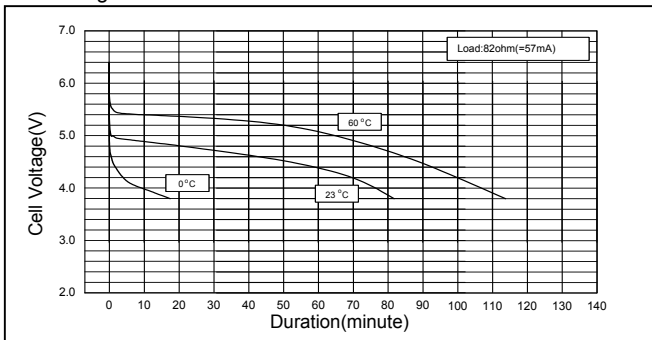

Discharge Characteristics of 2CR1/3N

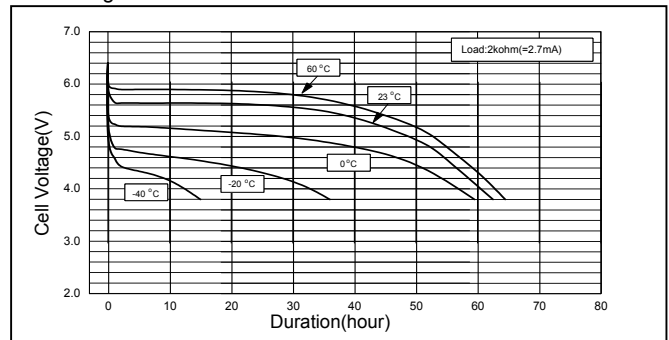

Discharge Characteristics of 2CR1/3N

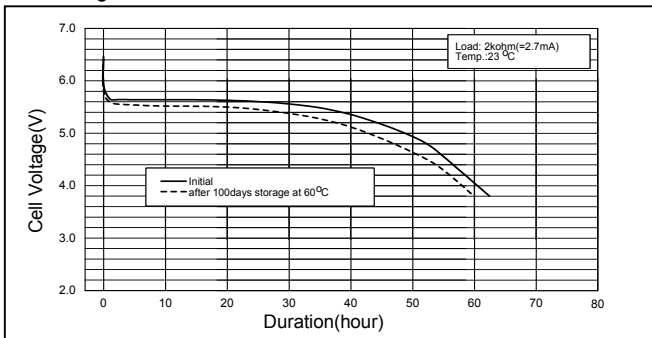

Discharge Load vs. Capacity of 2CR1/3N

