



GHz TECHNOLOGY
RF-MICROWAVE SILICON POWER TRANSISTORS

0912-45

POWER OUTPUT vs POWER INPUT

Vcc = 50 V, F = 1090 MHz

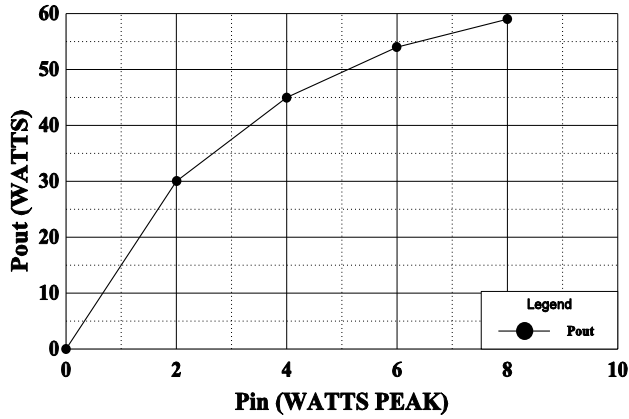

WIDEBAND CIRCUIT INPUT RETURN LOSS

Vcc = 50 V, Pin = 7.0 W

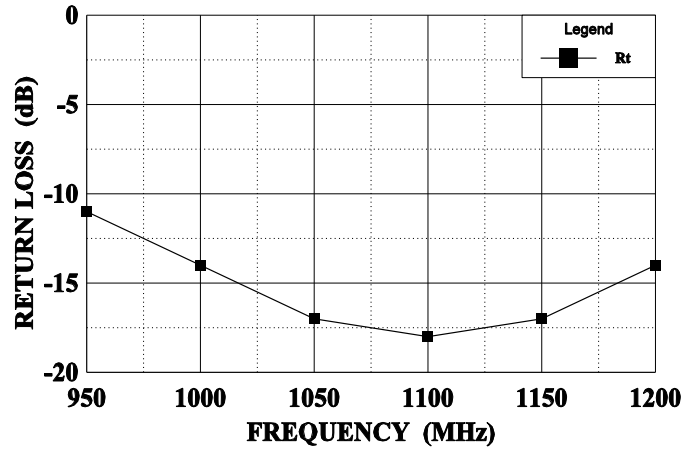

EFFICIENCY vs FREQUENCY

Vcc = 50 V, Pin = 7.0 W

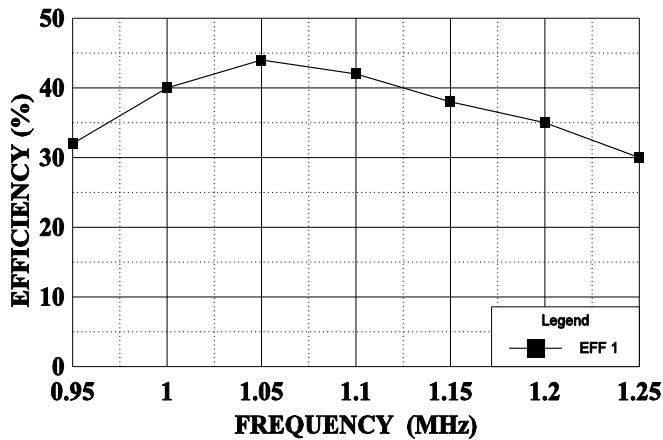

SERIES INPUT IMPEDANCE vs FREQUENCY

Vcc = 50 V, Pin = 7.0 W

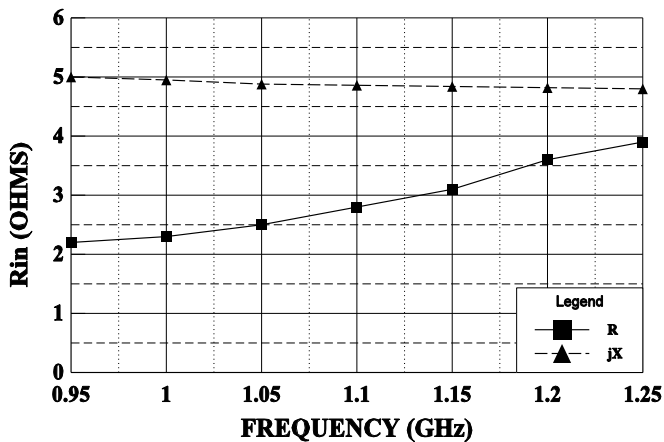

SERIES LOAD IMPEDANCE vs FREQUENCY

Vcc = 50 V, Pin = 7.0 W

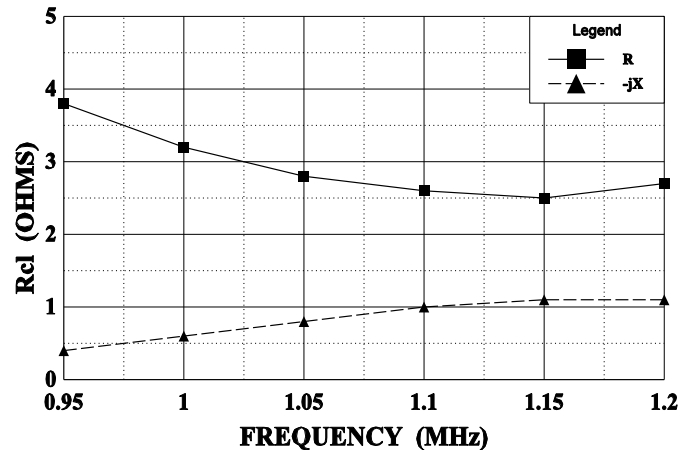

0912-45 BROADBAND CIRCUIT

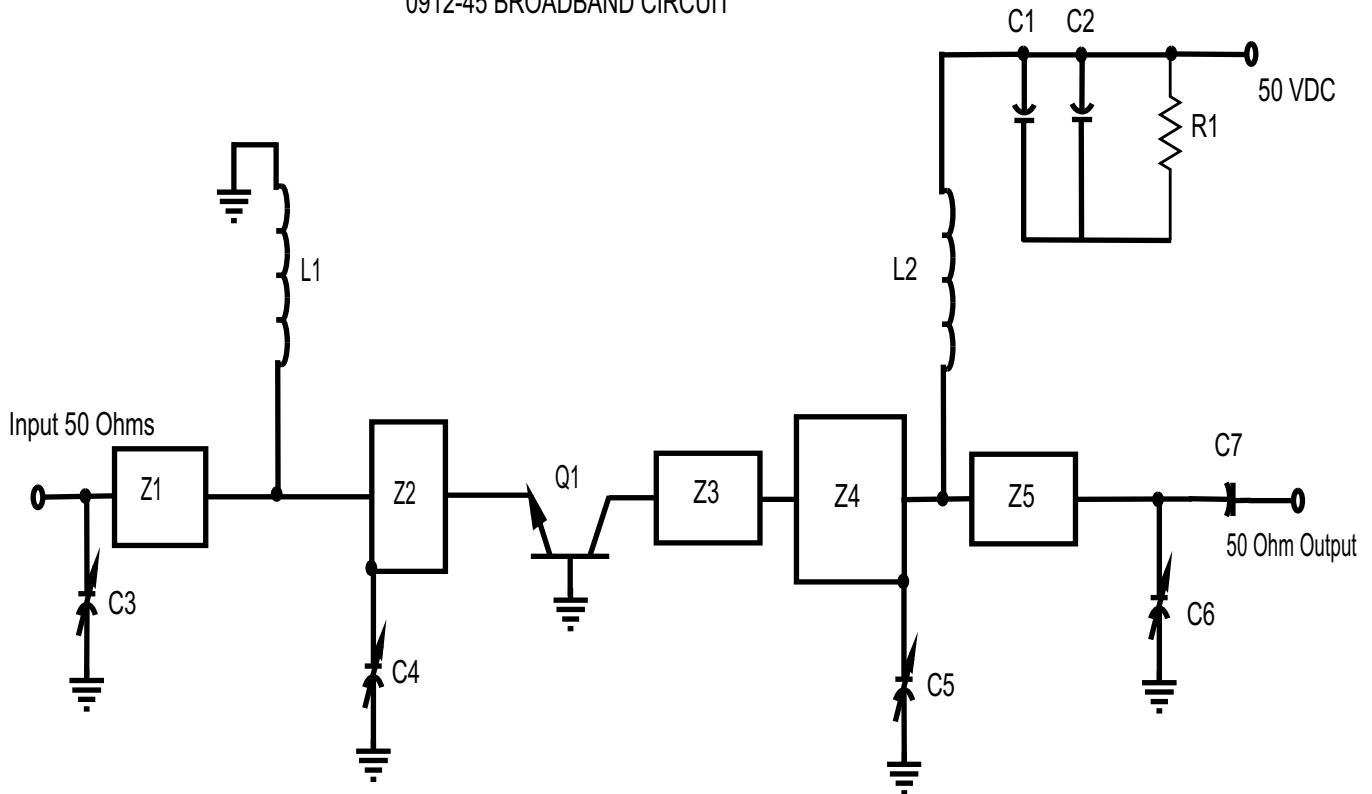

PC Board Material .010" Dielectric Teflon Fiberglass

Z1=50 , .08 , = .027"w X .59"L
 Z2=2.7 .064 , = .80"w X .44"L
 Z3=10 , .062 , = .20"w X .443"L
 Z4=3.7 , .08 , = .55"w X .55"L
 Z5=50 , .075 , = .027"w X .56"L
 L1= Inductor #14 wire, 0.7" long
 L2= Inductor #18 wire, 1.5" long

C1=Capacitor 100 pF "B" (100mil) ATC
 C2=Capacitor 68mfd, 75V Electrolytic
 C3, C4, C5, C6= Capacitor .35-3.5pF Piston Trimmer
 C4=Capacitor 47pF "B" (100mil) ATC
 R1= Resistor, 15WK 1/4W
 Q1=GHz Transistor 0912-45

All electrical lengths taken at 1.09 GHz