

# Customer Information Sheet

DRAWING No.: Z80-044C & Z80-044D

IF IN DOUBT - ASK

©

NOT TO SCALE

THIRD ANGLE PROJECTION

ALL DIMENSIONS IN mm

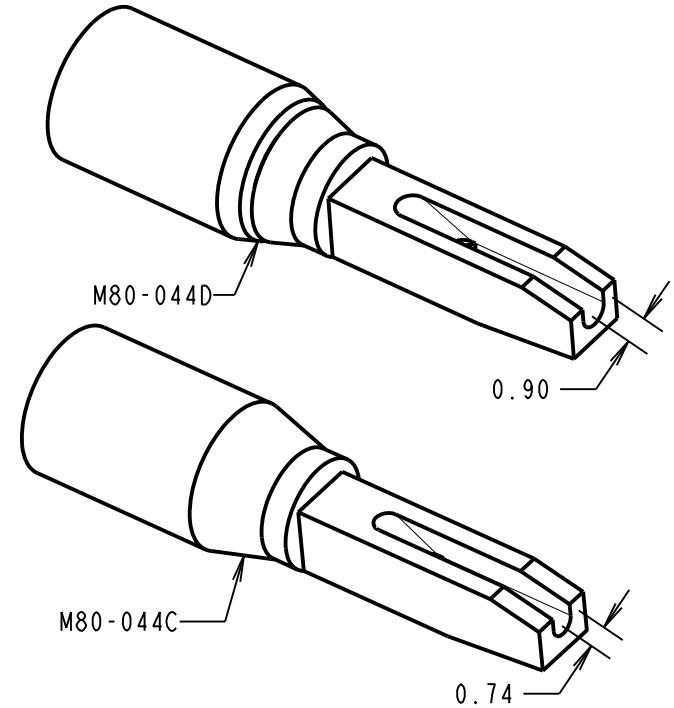
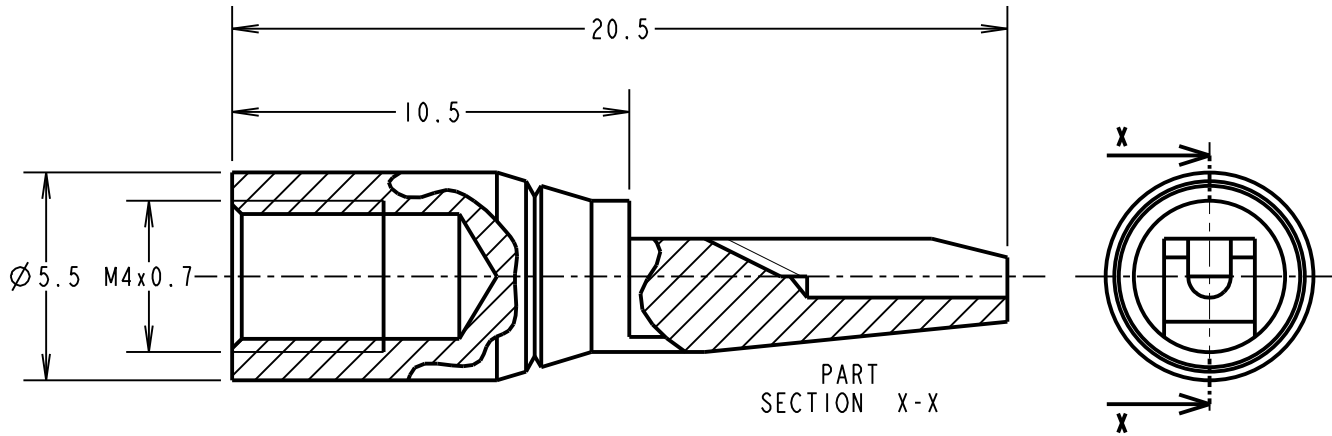

**NOTES:**

1. TIP IS SUITABLE FOR USE WITH INSERTION AND WITHDRAWAL TOOL Z80-280.
2. FOR USE WITH M80-01100XX, M80-01200XX, M80-01900XX, M80-19400XX & M80-19500XX CRIMP CONTACTS.
3. SEE TOOLING INSTRUCTION SHEET IS-25 FOR INSERTION AND WITHDRAWAL INSTRUCTIONS.
4. M80-044C IS SUITABLE FOR WIRES WITH INSULATION UP TO 0.90mm & M80-044D IS SUITABLE FOR WIRES WITH INSULATION FROM 0.90mm to 1.10mm.

RTP	6	14.01.21	30342
NAME	ISS.	DATE	CN/CO
APPROVED:		R.PORTLOCK	
CHECKED:		M.RUDKIN	
DRAWN:		R.PORTLOCK	
CUSTOMER REF.:			
ASSEMBLY DRG:			

**HARWIN**

www.harwin.com  
technical@harwin.com

THIS DRAWING AND ANY INFORMATION OR DESCRIPTIVE MATTER SET OUT HEREON ARE CONFIDENTIAL AND COPYRIGHT PROPERTY OF THE HARWIN GROUP AND MUST NOT BE DISCLOSED, LOANED, COPIED OR USED FOR MANUFACTURING, TENDERING OR FOR ANY OTHER PURPOSE WITHOUT THEIR WRITTEN PERMISSION.

**TOLERANCES**  
 X. = ±1mm  
 X.X = ±0.50mm  
 X.XX = ±0.20mm  
 X.XXX = ±0.01mm  
 ANGLES = ±5°  
 UNLESS STATED

**MATERIAL:**  
 STAINLESS STEEL  
**FINISH:** CLEAN  
**S/AREA:** mm<sup>2</sup>

**TITLE:**  
 INSERTION TOOL FOR  
 CRIMP SOCKET CONTACT  
**DRAWING NUMBER:**  
 Z80-044C & Z80-044D

SHT  
2 OF 2