

NO. OF CIRCUITS	DIM. "A"		DIM. "B"		DIM. "C"		DIM. "D"		ASSEMBLY MATERIAL NO. (STANDARD)	ASSEMBLY MATERIAL NO. (-50 OPT)
	mm	in	mm	in	mm	in	mm	in		
02	32.1	1.27	8.3	.33	24.8	.98	17.9	.71	386912102	386913302
03	40.4	1.59	16.5	.65	33.0	1.30	26.2	1.03	386912103	386913303
04	48.6	1.92	24.8	.98	41.3	1.63	34.4	1.36	386912104	386913304
05	56.9	2.24	33.0	1.30	49.5	1.95	42.7	1.68	386912105	386913305
06	65.2	2.57	41.3	1.63	57.8	2.28	50.9	2.01	386912106	386913306
07	73.4	2.89	49.5	1.95	66.0	2.60	59.2	2.33	386912107	386913307
08	81.7	3.22	57.8	2.28	74.3	2.93	67.4	2.66	386912108	386913308
09	89.9	3.54	66.0	2.60	82.6	3.25	75.7	2.98	386912109	386913309
10	98.2	3.87	74.3	2.93	90.8	3.58	83.9	3.31	386912110	386913310
11	106.4	4.19	82.6	3.25	99.1	3.90	92.2	3.63	386912111	386913311
12	114.7	4.52	90.8	3.58	107.3	4.23	100.5	3.96	386912112	386913312
13	122.9	4.84	99.1	3.90	115.6	4.55	108.7	4.28	386912113	386913313
14	131.2	5.17	107.3	4.23	123.8	4.88	117.0	4.61	386912114	386913314
15	139.4	5.49	115.6	4.55	132.1	5.20	125.2	4.93	386912115	386913315
16	147.7	5.82	123.8	4.88	140.3	5.53	133.5	5.26	386912116	386913316
17	156.0	6.14	132.1	5.20	148.6	5.85	141.7	5.58	386912117	386913317
18	164.2	6.47	140.3	5.53	156.8	6.18	150.0	5.91	386912118	386913318
19	172.5	6.79	148.6	5.85	165.1	6.50	158.2	6.23	386912119	386913319
20	180.7	7.12	156.8	6.18	173.4	6.83	166.5	6.56	386912120	386913320
21	189.0	7.44	165.1	6.50	181.6	7.15	174.8	6.88	386912121	386913321
22	197.2	7.77	173.4	6.83	189.9	7.48	183.0	7.21	386912122	386913322
23	205.5	8.09	181.6	7.15	198.1	7.80	191.3	7.53	386912123	386913323
24	213.7	8.42	189.9	7.48	206.4	8.13	199.5	7.86	386912124	386913324
25	222.0	8.74	198.1	7.80	214.6	8.45	207.8	8.18	386912125	386913325
26	230.3	9.07	206.4	8.13	222.9	8.78	216.0	8.51	386912126	386913326
27	238.5	9.39	214.6	8.45	231.1	9.10	224.3	8.83	386912127	386913327
28	246.8	9.72	222.9	8.78	239.4	9.43	232.5	9.16	386912128	386913328
29	255.0	10.04	231.1	9.10	247.7	9.75	240.8	9.48	386912129	386913329
30	263.3	10.37	239.4	9.43	255.9	10.08	249.0	9.81	386912130	386913330
31	271.5	10.69	247.7	9.75	264.2	10.40	257.3	10.13	386912131	386913331
32	279.8	11.02	255.9	10.08	272.5	10.73	265.6	10.46	386912132	386913332

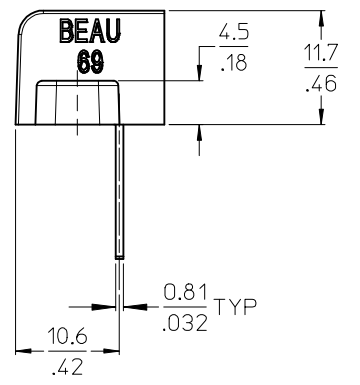
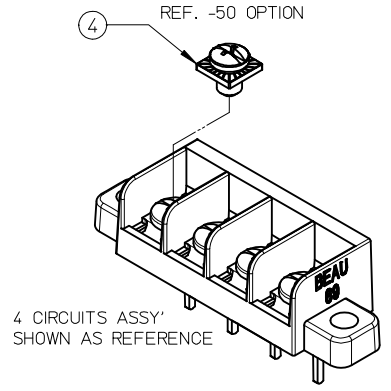
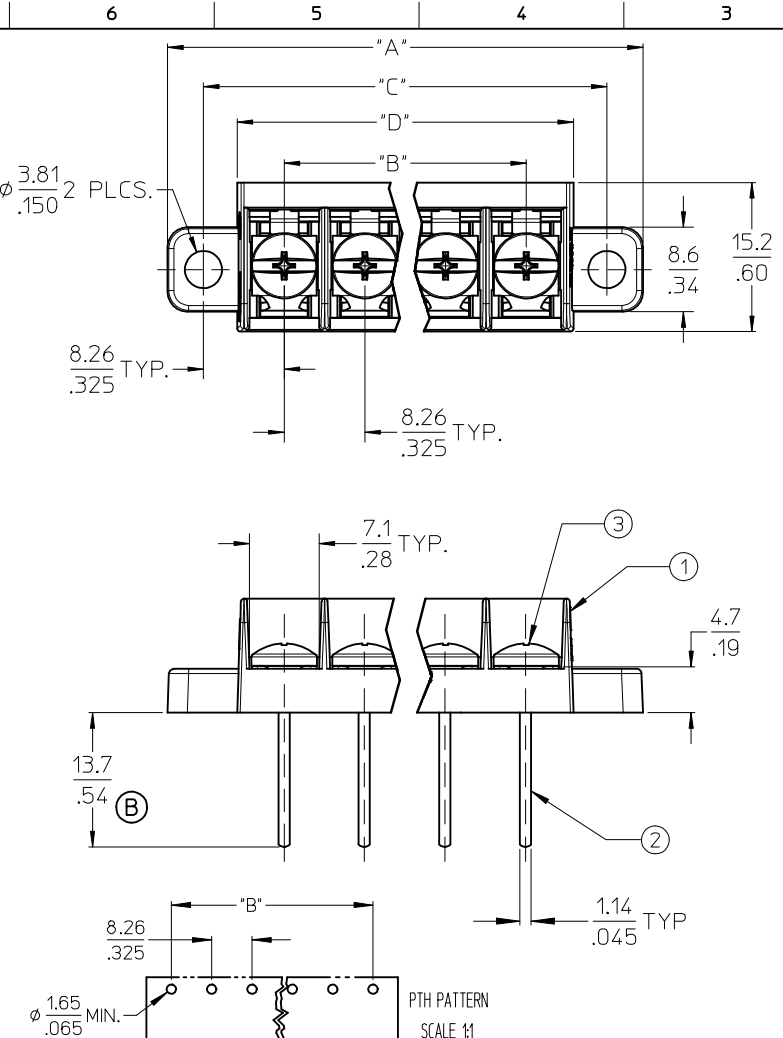

- NOTES:
1. MATERIAL: SEE TABLE
  2. FINISHES: SEE TABLE.
  3. "XX" REFERS TO THE QUANTITY OF CIRCUITS.
  4. ROHS COMPLIANT.

ITEM	QTY.	DESCRIPTION	MATERIAL	FINISH
4	XX	SCREW #6-32X.155 PAN PHLZLN/BR/STEEL -50 OPT	STEEL	ZN, CLEAR CHROMATE
3	XX	SCREW #6-32X.160 PAN PHLN/BRASS (STANDARD)	BRASS	NICKEL PLATE
2	XX	TERMINAL, PC	BRASS	TIN PLATE
1	1	INSULATOR	POLYESTER (PBT)	BLACK

<b>DRAWING ERROR</b> EC NO: IPG2013-0687 2012/10/29 DRAWN: JENCINAS 2013/01/14 CHKD: JMACNEIL 2013/02/01 APPR: JMACNEIL	QUALITY SYMBOLS ▽=0 ▽=0	GENERAL TOLERANCES (UNLESS SPECIFIED)		DIMENSION STYLE <b>MM/IN</b>		SCALE <b>2:1</b>	DESIGN UNITS INCH	THIRD ANGLE PROJECTION
		4 PLACES ± --- ± --- 3 PLACES ± --- ± .005 2 PLACES ± 0.13 ± .01 1 PLACE ± 0.3 ± ---	DRAWN BY JENCINAS	DATE 2012/07/17	TITLE <b>8.26/.325 SR TRI-BARRIER TERMINAL STRIP CS, PC ASSY</b>			
		ANGULAR ± 2°	CHECKED BY JMACNEIL	DATE 2012/07/17	MOLEX INCORPORATED			
		DRAFT WHERE APPLICABLE MUST REMAIN WITHIN DIMENSIONS	APPROVED BY JMACNEIL	DATE 2012/09/14	MATERIAL NO. <b>SEE CHART</b>	DOCUMENT NO. <b>SD-38691-004</b>	SHEET NO. 1 OF 1	